

SPECIFICATION CONTROL DRAWING

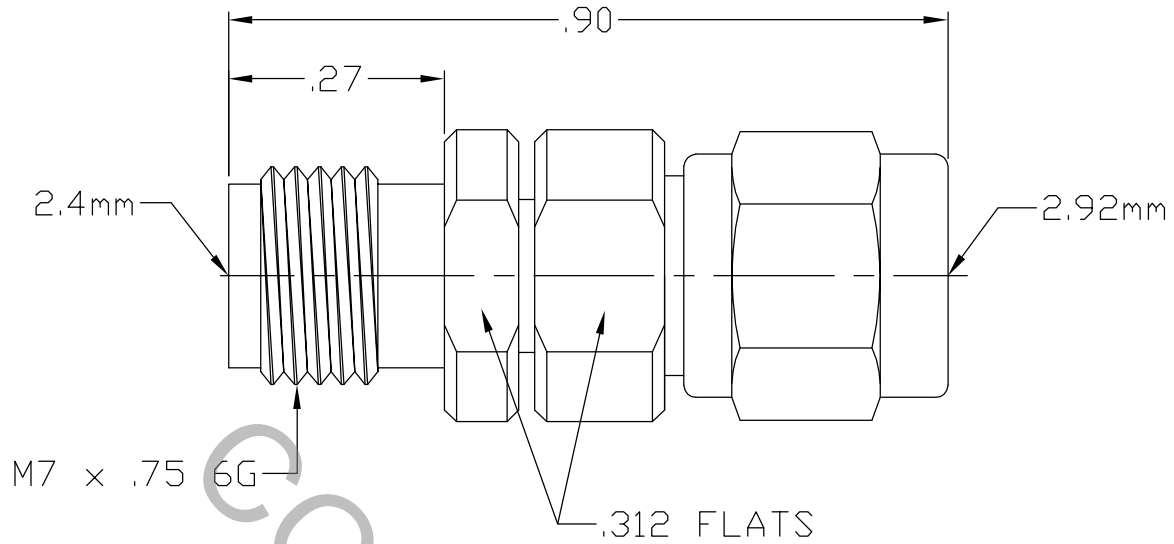

1. MATING INTERFACE DIMENSIONS, 2.4mm JACK Per DYNAWAVE SPECIFICATION MD-13.
 INTERFACE DIMENSIONS, 2.9mm PLUG Per DYNAWAVE SPECIFICATION MD-94.

2. ELECTRICAL

FREQUENCY RANGE GHz _____ DC TO 40.0 GHz
 VSWR (MAX.) * _____ DC - 18.0 GHz. _____ 1.10:1
 18.0 - 26.5 GHz. _____ 1.14:1
 26.5 - 40.0 GHz. _____ 1.29:1

INSERTION LOSS (dB MAX.) * _____ .035 dB x \sqrt{FGHz}
 NOMINAL IMPEDANCE (OHMS) _____ 50
 VOLTAGE RATING (MAX. VRMS) _____ 335
 RF LEAKAGE (MIN. dB DOWN) _____ -100 dB - FGHz
 TEMPERATURE RATING (DEGREES CENTIGRADE) _____ -65°c TO + 165°c
 DIELECTRIC WITHSTANDING VOLTAGE (MAX. VRMS) _____ 750
 INSULATION RESISTANCE (MIN. MEGOHMS) _____ 5,000

CONTACT RESISTANCE

- CENTER CONTACT (MAX. MILLIOHMS) _____ 6.0
- OUTER CONTACT (MAX. MILLIOHMS) _____ 2.0

* "GATED" TEST DATA

REV.	DCN NO.	DATE	APP.	DIMENSIONS ARE IN INCHES TOLERANCES			 HAVERHILL, MA 01835
AA	06-2204	9/29/06	DC	DECIMALS	FRACTIONAL	ANGULAR	
				.X + .030 .XX ± .010 .XXX ± .005	± 1/64	X ° ± 1'0" X ° X' ± 15'	TITLE 2.4mm JACK TO 2.9mm PLUG ADAPTER
				DRAWN DC	DATE 9/29/06		
				APPROVED DC	DATE 9/29/06		
				CODE IDENT. 2J899	SHEET 1 OF 2	DWG. NO. 1100-1394-6250	

SPECIFICATION CONTROL DRAWING

3. MECHANICAL

CAPTIVATION-CENTER CONTACT
 MAX AXIAL FORCE _____ 6.0 LBS.
 MAX. RADIAL TORQUE _____ N/A
 CENTER CONTACT AXIAL FORCES
 ● INSERTION (MAX. OUNCES) _____ 32.0
 ● WITHDRAWAL (MIN. OUNCES) _____ 2.0
 CONNECTOR ENGAGEMENT/DISENGAGEMENT (MAX. LBS.) _____ 2.0
 CONNECTOR DURABILITY (MIN. CYCLES) _____ 1000
 RECOMMENDED MATING TORQUE _____ 7 - 10 IN. LBS.

4. ENVIRONMENTAL

TEMPERATURE CYCLING _____ MIL-STD-202, METHOD 102, COND. C (-65° c TO +125° c)
 SHOCK _____ MIL-STD-202, METHOD 213, COND. I (100 G's)
 VIBRATION _____ MIL-STD-202, METHOD 204, COND. D (20 G's)
 MOISTURE RESISTANCE _____ MIL-STD-202, METHOD 106, LESS STEP 7b
 CORROSION _____ MIL-STD-202, METHOD 101, COND. B (48 HOURS)
 BAROMETRIC PRESSURE (ALTITUDE) _____ MIL-STD-202, METHOD 105, COND. C (70,000 FT.) (190 VRMS)

5. MATERIAL

BODIES AND COUPLING NUT _____ STAINLESS STEEL PER AMS 5640, TYPE 303, COND. A
 CONTACTS AND RETAINING RING _____ BERYLLIUM COPPER PER ASTM B196-90, COPPER ALLOY
 No. UNS-C17300, TEMPER T004.
 INSULATOR _____ PLASTIC COMPOSIT
 GASKET _____ SILICONE RUBBER PER ZZ-R-765

6. FINISH

BODIES AND COUPLING NUT _____ PASSIVATE PER AMS QQ-P-35, TYPE 2
 CONTACTS _____ GOLD PER ASTM-B-488, TYPE I, CODE C, CLASS .75
 (.000030 MIN. THK.) OVER NICKEL per QQ-N-290
 (.000050 MIN. THK.) OVER COPPER per MIL-C-14550
 (.000010 MIN. THK.)
 INSULATOR, RETAINING RING AND GASKET _____ N/A