

SPECIFICATION CONTROL DRAWING

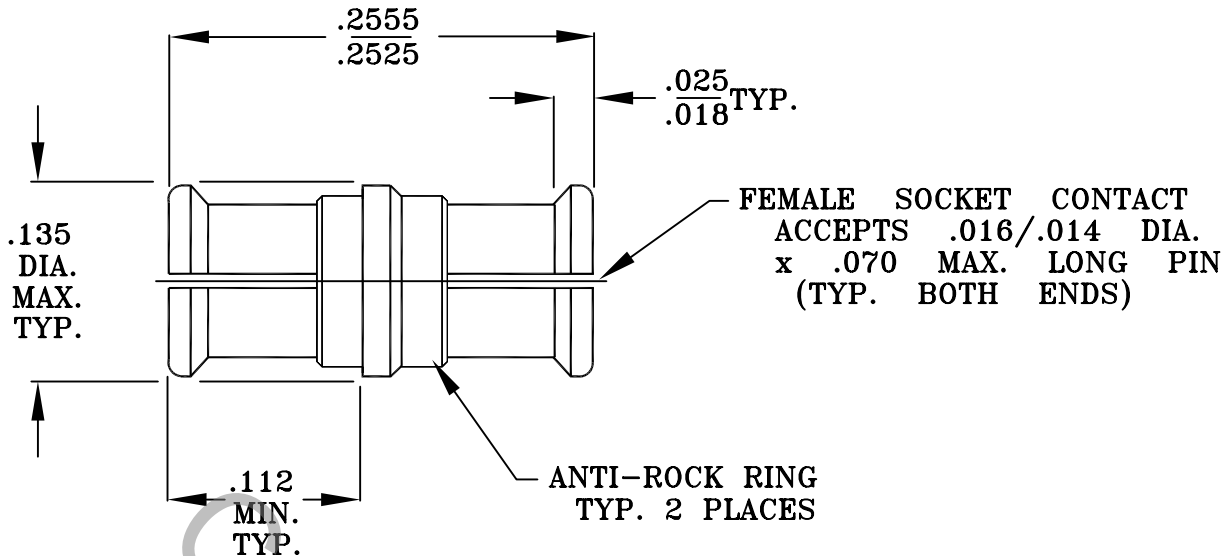

1. MATING INTERFACE DIMENSIONS (SMP SERIES) PER DYNAWAVE SPECIFICATION MD-20-99.

2. ELECTRICAL

FREQUENCY RANGE (DC TO 23.0 GHz.) *	_____	VSWR 1.10 MAX.
FREQUENCY RANGE (23.0 TO 26.5 GHz.) *	_____	VSWR 1.15 MAX.
FREQUENCY RANGE (26.5 TO 40.0 GHz.) *	_____	VSWR 1.40 MAX.
INSERTION LOSS (dB MAX.)	_____	.10 dB x \sqrt{FGHz} .
NOMINAL IMPEDANCE (OHMS)	_____	50
VOLTAGE RATING (MAX. VRMS)	<input type="text"/>	170 @ SEA LEVEL
(OVER FREQ. RANGE)		45 @ 70,000 FEET
RF LEAKAGE (MIN. dB DOWN)	<input type="text"/>	80 dB (3 GHz.)
		65 dB (26.5 GHz.)
TEMPERATURE RATING (DEGREES CENTIGRADE)	_____	-65° c TO + 165° c
DIELECTRIC WITHSTANDING VOLTAGE (MAX. VRMS)	<input type="text"/>	500 @ SEA LEVEL
		125 @ 70,000 FEET
INSULATION RESISTANCE (MIN. MEGOHMS)	_____	5,000
CONTACT RESISTANCE		
• CENTER CONTACT (MAX. MILLIOHMS)	_____	6.0
• OUTER CONTACT (MAX. MILLIOHMS)	_____	2.0

***TESTED IN ACCORDANCE WITH DSCC 94007**

REV.	DCN NO.	DATE	APP.	DIMENSIONS ARE IN INCHES TOLERANCES			dynawave INCORPORATED HAVERHILL, MA. 01835
				DECIMALS	FRACTIONAL	ANGULAR	
AA	97-0521	9/16/97	DGG	.X +.030 .XX ±.010 .XXX ±.005	1/64	X° ± 1' 0" X° X' ± 15"	TITLE "SMP" INTERCONNECT ADAPTER JACK TO JACK
AB	97-0606	10/23/97	DGG	SURFACE ROUGHNESS 63 √ MIL-STD 10.			
AC	98-0455	5/28/98	DGG	DRAWN	TS	DATE 9/16/97	DWG. NO. 1100-2020-5499
AD	99-0403	5/17/99	DGG	APPROVED DGG DATE 9/16/97			
				CODE IDENT.	SHEET 1 OF 2		
				2J899			

SPECIFICATION CONTROL DRAWING

3. MECHANICAL

CAPTIVATION-CENTER CONTACT

- MIN. AXIAL FORCE _____ 1.5 LBS.
- MIN. RADIAL TORQUE _____ N/A

RADIAL MISALIGNMENT _____ +/- .005

AXIAL MISALIGNMENT _____ .010 MIN.

CONNECTOR DURABILITY (MIN. MATING) _____

- A.) FULL DETENT _____ 100
- B.) LIMITED DETENT _____ 500
- C.) SMOOTH BORE _____ 1000

4. ENVIRONMENTAL

THERMAL SHOCK _____ MIL-STD-202, METHOD 107, COND. B (HIGH TEMP. +165°c)

SHOCK _____ MIL-STD-202, METHOD 213, COND. I (100 G's)

VIBRATION _____ MIL-STD-202, METHOD 204, COND. D (20 G's)

MOISTURE RESISTANCE _____ MIL-STD-202, METHOD 106, LESS STEP 7b,
1000 MEGOHMS MINIMUM WITHIN 5 MINUTES.

CORONA (70,000 FEET) _____ 190 VRMS

RF HIGH POTENTIAL MIN. VOLTS _____ 325 VRMS @ SEA LEVEL, FREQ. 5 MHz.

VIBRATION, RANDOM _____ MIL-STD 202, METHOD 214, TEST CONDITION F

5. MATERIAL

CONNECTOR BODY, CENTER CONTACT _____ BERYLLIUM COPPER PER ASTM B196-90, COPPER ALLOY
AND ANTI-ROCK RINGS _____ No. UNS C17300, TEMPER TD04.

INSULATOR _____ TEFLON PER ASTM D 1710.

6. FINISH

CONNECTOR BODY, CENTER CONTACT _____ GOLD PER MIL-G-45204, TYPE II, GRADE C, CLASS 1
AND ANTI-ROCK RINGS _____ (.000050 MIN.) OVER NICKEL PER QQ-N-290 (.000050 MIN.)

INSULATOR _____ N/A