

SPECIFICATION CONTROL DRAWING

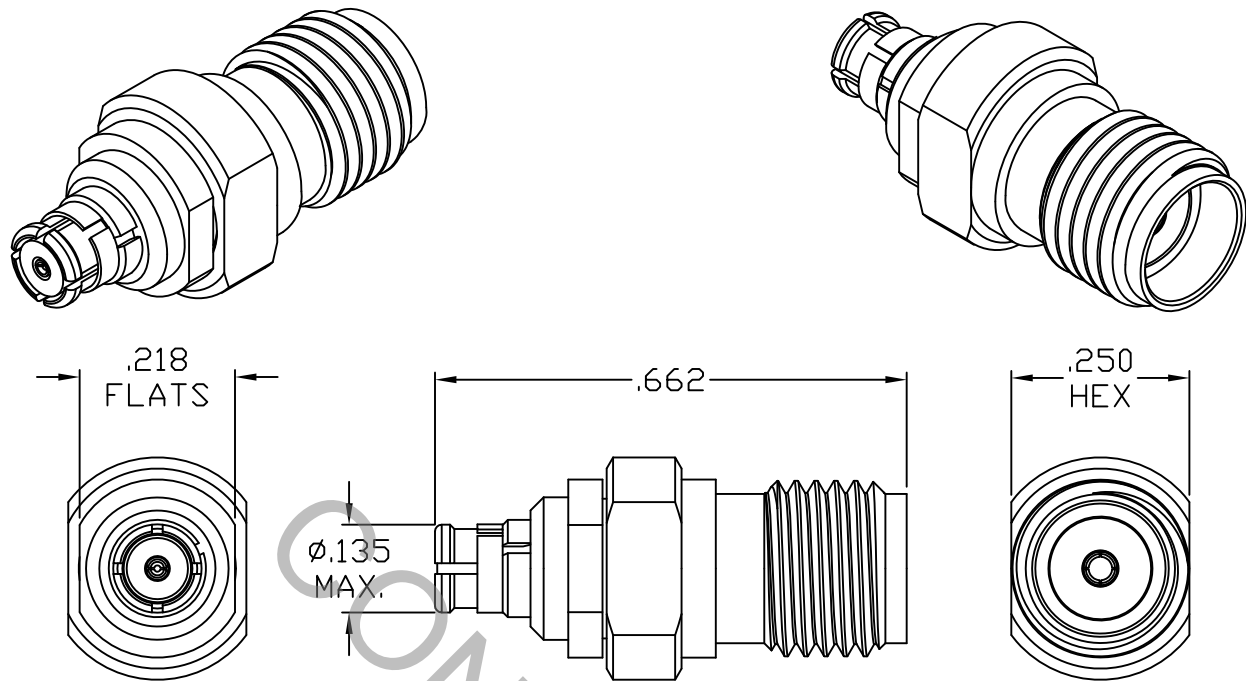

1. MATING INTERFACE DIMENSIONS Per MIL-STD-348 Fig. 310.2 (SMA JACK)
AND Per MIL-STD-348 Fig. 326.1A (SMP FEMALE)

2. ELECTRICAL

FREQUENCY RANGE GHz	_____	DC TO 26.5 GHz
VSWR (MAX) *	_____	1.05 + .010 x FGHz
INSERTION LOSS (dB MAX) *	_____	.10 dB x $\sqrt{\text{FGHz}}$
NOMINAL IMPEDANCE (OHMS)	_____	50
VOLTAGE RATING (MAX. VRMS)	_____	190
RF LEAKAGE (MIN. dB DOWN)	_____	-85 dB - FGHz
TEMPERATURE RATING (DEGREES CENTIGRADE)	_____	-65°C TO + 165°C
DIELECTRIC WITHSTANDING VOLTAGE (MAX. VRMS)	_____	500
INSULATION RESISTANCE (MIN. MEGOHMS)	_____	5,000
CONTACT RESISTANCE		
• CENTER CONTACT (MAX. MILLIOHMS)	_____	3.0
• OUTER CONTACT (MAX. MILLIOHMS)	_____	2.0

* TERMINATED IN A 50 OHM LOAD

RoHS

This Document contains proprietary and confidential information. COMPLIANT

REV.	DCN NO.	DATE	APP.	DIMENSIONS ARE IN INCHES TOLERANCES			 Haverhill, MA 01835
AA	15-2579	11/3/15	TS	DECIMALS	FRACTIONAL	ANGULAR	
				.X ± .030		X ° ± 1° 0'	TITLE SMP FEMALE TO SMA JACK ADAPTER
				.XX ± .010	± 1/64	X ° X' ± 15'	
				.XXX ± .005			
				DRAWN TS	DATE	11/3/15	DWG. NO. 1100-2099-6225
				APPROVED DC	DATE	11/3/15	
				CODE IDENT.	SHEET 1 OF 2		
				2J899			

SPECIFICATION CONTROL DRAWING

3. MECHANICAL

CAPTIVATION-CENTER CONTACT

MAX AXIAL FORCE _____ 4.0 LBS.

MAX RADIAL TORQUE _____ N/A

CENTER CONTACT AXIAL FORCES

● INSERTION (MAX OUNCES) _____ INTERFACE 32.0

● WITHDRAWAL (MIN. OUNCES) _____ INTERFACE 2.0

CONNECTOR ENGAGEMENT/DISENGAGEMENT (MAX. LBS.) _____ SMA, 2.0

SMP FULL DETENT (LBS.) _____ 15.0 MAX / 5.0 MIN.

SMP LIMITED DETENT (LBS.) _____ 10.0 MAX / 2.0 MIN.

SMP SMOOTH BORE (LBS.) _____ 2.0 MAX / 0.5 MIN.

CONNECTOR DURABILITY (MIN. CYCLES) _____ 100

RECOMMENDED MATING TORQUE _____ SMA 7 - 10 IN. LBS., SMP N/A

4. ENVIRONMENTAL

THERMAL SHOCK _____ MIL-STD-202, METHOD 107, COND. B (-65° c TO + 165° c)

SHOCK _____ MIL-STD-202, METHOD 213, COND. I (100 G's)

VIBRATION _____ MIL-STD-202, METHOD 204, COND. D (20 G's)

MOISTURE RESISTANCE _____ MIL-STD-202, METHOD 106, LESS STEP 7b

CORROSION _____ MIL-STD-202, METHOD 101, COND. B (48 HOURS)

BAROMETRIC PRESSURE (ALTITUDE) _____ MIL-STD-202, METHOD 105, COND. C (70,000 FT.) (125 VRMS)

5. MATERIAL

SMA BODY _____ STAINLESS STEEL PER ASTM-A-582, TYPE 303, COND. A

SMP BODY, CONTACT, EMI RING & ANTI-ROCK RING _____ BERYLLIUM COPPER PER ASTM-B-196/B, 196M-03, COPPER ALLOY No. UNS-C17300, TEMPER T004.

INSULATOR _____ TEFLON PER ASTM-D-1710-02, TYPE 1, GRADE 1, CLASS B.

6. FINISH

SMA BODY _____ PASSIVATE PER AMS 2700, TYPE 2, CLASS 4.

SMP BODY, EMI RING & ANTI-ROCK RING _____ GOLD PER ASTM-B-488, TYPE I, CODE C, CLASS 0.70 (.000030 MIN. THK.) OVER NICKEL PER SAE-AMS-QQ-N-290 CLASS 1 (.000050 MIN. THK.) OVER COPPER PER AMS-2418, (.000010 MIN. THK.).

CONTACT _____ GOLD PER ASTM-B-488, TYPE I, CODE C, CLASS 1.25 (.000050 MIN. THK.) OVER NICKEL PER SAE-AMS-QQ-N-290 CLASS 1 (.000050 MIN. THK.) OVER COPPER PER AMS-2418 (.000010 MIN. THK.)

INSULATOR _____ N/A