

# SPECIFICATION CONTROL DRAWING

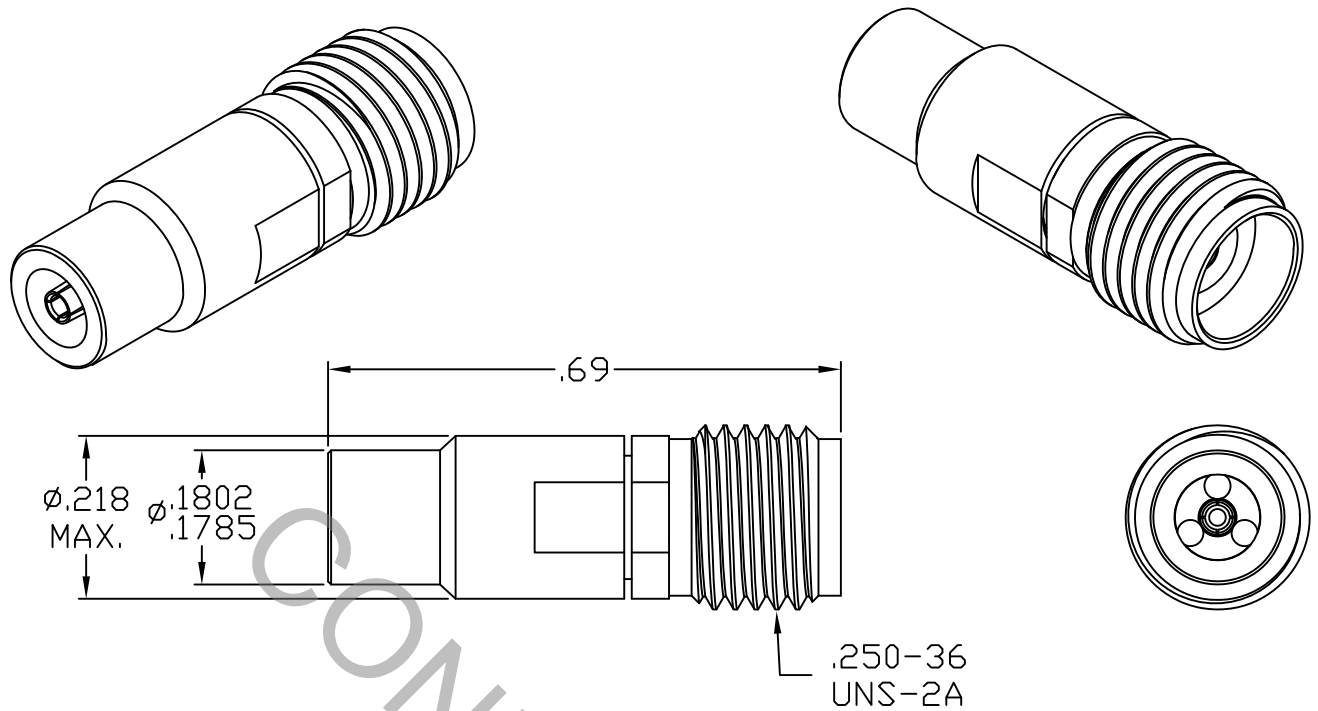

1. MATING INTERFACE DIMENSIONS MIL-STD-348 Fig. 322.2 (BMB JACK). MODIFIED WITH SOLID OUTER AND AIR DIELECTRIC AND PER MIL-STD-348 Fig.323.2 (SMK JACK)
2. ELECTRICAL

FREQUENCY RANGE GHz	_____	DC TO 40.0 GHz
VSWR (MAX.) *	_____	1.05 + .005 x FGHz
INSERTION LOSS (dB MAX.) *	_____	.05 dB x $\sqrt{\text{FGHz}}$
NOMINAL IMPEDANCE (OHMS)	_____	50
VOLTAGE RATING (MAX. VRMS)	_____	250
RF LEAKAGE (MIN. dB DOWN)	_____	100 dB - FGHz
TEMPERATURE RATING (DEGREES CENTIGRADE)	_____	-65°C TO + 125°C
DIELECTRIC WITHSTANDING VOLTAGE (MAX. VRMS)	_____	750
INSULATION RESISTANCE (MIN. MEGOHMS)	_____	5,000
CONTACT RESISTANCE		
• CENTER CONTACT (MAX. MILLIOHMS)	_____	6.0
• OUTER CONTACT (MAX. MILLIOHMS)	_____	2.0

\* TERMINATED IN A 50 OHM LOAD

**RoHS**  
COMPLIANT

This Document contains proprietary and confidential information.

REV.	DCN NO.	DATE	APP.	DIMENSIONS ARE IN INCHES TOLERANCES			 HAVERHILL, MA 01835		
AA	18-1322	3/21/18	TS	DECIMALS .X ± .030 .XX ± .010 .XXX ± .005	FRACTIONAL ± 1/64	ANGULAR X ° ± 1'0" X ° X' ± 15'	TITLE BMB JACK, 2.92mm JACK TEST ADAPTER		
				DRAWN MS	DATE 3/21/18				
				APPROVED TS	DATE 3/21/18				
				CODE IDENT. 2J899	SHEET 1 OF 2	DWG. NO.	1100-2595-6241		

# SPECIFICATION CONTROL DRAWING

## 3. MECHANICAL

### CAPTIVATION-CENTER CONTACT

MAX AXIAL FORCE \_\_\_\_\_ 4.5 LBS.

MAX RADIAL TORQUE \_\_\_\_\_ N/A

### CENTER CONTACT AXIAL FORCES

● INSERTION (MAX OUNCES) \_\_\_\_\_ INTERFACE 32.0

● WITHDRAWAL (MIN. OUNCES) \_\_\_\_\_ INTERFACE 2.0

CONNECTOR ENGAGEMENT/DISENGAGEMENT (MAX IN. LBS.) — 2.0

CONNECTOR DURABILITY (MIN. CYCLES) \_\_\_\_\_ 500

RECOMMENDED MATING TORQUE \_\_\_\_\_ 7 - 10 IN. LBS.

## 4. ENVIRONMENTAL

TEMPERATURE CYCLING \_\_\_\_\_ MIL-STD-202, METHOD 102, COND. C ( -65° c TO +125° c )

SHOCK \_\_\_\_\_ MIL-STD-202, METHOD 213, COND. I (100 G's)

VIBRATION \_\_\_\_\_ MIL-STD-202, METHOD 204, COND. D (20 G's)

MOISTURE RESISTANCE \_\_\_\_\_ MIL-STD-202, METHOD 106, LESS STEP 7b

CORROSION \_\_\_\_\_ MIL-STD-202, METHOD 101, COND. B (48 HOURS)

BAROMETRIC PRESSURE (ALTITUDE) — MIL-STD-202, METHOD 105, COND. C ( 70,000 FT. ) ( 190 VRMS )

## 5. MATERIAL

BODIES \_\_\_\_\_ STAINLESS STEEL PER ASTM-A-581, TYPE 303, COND. A

CONTACTS \_\_\_\_\_ BERYLLIUM COPPER PER ASTM B196/B, 196M-03, COPPER  
ALLOY No. UNS-C17300, TEMPER TD04.

INSULATOR \_\_\_\_\_ PLASTIC COMPOSITE

## 6. FINISH

BODIES \_\_\_\_\_ PASSIVATE PER AMS 2700, TYPE 2, CLASS 4.

CONTACTS \_\_\_\_\_ GOLD PER ASTM-B-488, TYPE I, CODE C, CLASS 0.75  
(.000030 MIN. THK.) OVER NICKEL PER SAE AMS QQ-N-290, CLASS 1  
(.000050 MIN. THK.) OVER COPPER PER AMS 2418 (.000010 MIN. THK.)

INSULATOR \_\_\_\_\_ N/A