

# SPECIFICATION CONTROL DRAWING

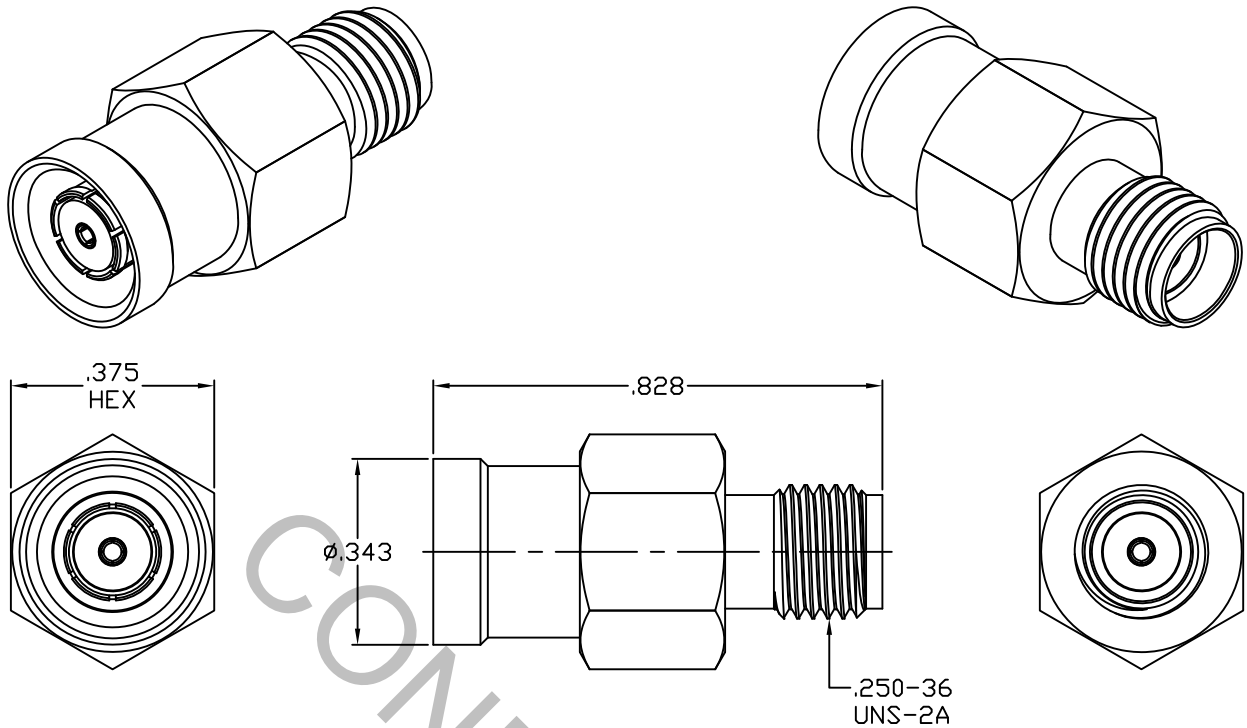

1. MATING INTERFACE DIMENSIONS Per MIL-STD-348 Fig. 322.2 (BMB JACK) AND MIL-STD-348 Fig. 310.2 (SMA JACK).

## 2. ELECTRICAL

FREQUENCY RANGE GHz	_____	DC TO 23.0 GHz
VSWR (MAX.) *	_____	1.05 + .005 x FGHz
INSERTION LOSS (dB MAX.) *	_____	.05 dB x $\sqrt{\text{FGHz}}$
NOMINAL IMPEDANCE (OHMS)	_____	50
VOLTAGE RATING (MAX. VRMS)	_____	250
RF LEAKAGE (MIN. dB DOWN)	_____	-85 dB - FGHz
TEMPERATURE RATING (DEGREES CENTIGRADE)	_____	-65°C TO + 165°C
DIELECTRIC WITHSTANDING VOLTAGE (MAX. VRMS)	_____	750
INSULATION RESISTANCE (MIN. MEGOHMS)	_____	5,000
CONTACT RESISTANCE		
• CENTER CONTACT (MAX. MILLIOHMS)	_____	6.0
• OUTER CONTACT (MAX. MILLIOHMS)	_____	2.0

\* TERMINATED IN A 50 OHM LOAD

This Document contains proprietary and confidential information.

**RoHS**  
COMPLIANT

REV.	DCN NO.	DATE	APP.	DIMENSIONS ARE IN INCHES TOLERANCES			 Haverhill, MA 01835
AA	17-1356	3/16/17	DC	DECIMALS	FRACTIONAL	ANGULAR	
				.X ± .030		X ° ± 1° 0'	TITLE BMB JACK TO SMA JACK ADAPTER
				.XX ± .010	± 1/64	X ° X' ± 15'	
				.XXX ± .005			
				DRAWN RMS	DATE	3/13/17	DWG. NO. 1100-2599-6242
				APPROVED DC	DATE	3/16/17	
				CODE IDENT.	SHEET 1 OF 2		
				2J899			

# SPECIFICATION CONTROL DRAWING

## 3. MECHANICAL

### CAPTIVATION-CENTER CONTACT

MAX AXIAL FORCE \_\_\_\_\_ 6.0 LBS.

MAX RADIAL TORQUE \_\_\_\_\_ N/A

### CENTER CONTACT AXIAL FORCES

● INSERTION (MAX OUNCES) \_\_\_\_\_ INTERFACES 32.0

● WITHDRAWAL (MIN. OUNCES) \_\_\_\_\_ INTERFACES 2.0

CONNECTOR ENGAGEMENT/DISENGAGEMENT (MAX LBS.) \_\_\_\_\_ 2.0

CONNECTOR DURABILITY (MIN. CYCLES) \_\_\_\_\_ 500

RECOMMENDED MATING TORQUE \_\_\_\_\_ 7 - 10 IN. LBS. SMA

## 4. ENVIRONMENTAL

TEMPERATURE CYCLING \_\_\_\_\_ MIL-STD-202, METHOD 102, COND. C ( -65° c TO + 165° c )

SHOCK \_\_\_\_\_ MIL-STD-202, METHOD 213, COND. I (100 G's)

VIBRATION \_\_\_\_\_ MIL-STD-202, METHOD 204, COND. D (20 G's)

MOISTURE RESISTANCE \_\_\_\_\_ MIL-STD-202, METHOD 106, LESS STEP 7b

CORROSION \_\_\_\_\_ MIL-STD-202, METHOD 101, COND. B (48 HOURS)

BAROMETRIC PRESSURE (ALTITUDE) \_\_\_\_\_ MIL-STD-202, METHOD 105, COND. C ( 70,000 FT. ) ( 190 VRMS )

## 5. MATERIAL

BODY \_\_\_\_\_ STAINLESS STEEL PER ASTM-A-582, TYPE 303, COND. A

CONTACT & SPRING FINGERS \_\_\_\_\_ BERYLLIUM COPPER PER ASTM B196/B 196M-03, COPPER ALLOY  
No. UNS-C17300, TEMPER TD04.

INSULATORS \_\_\_\_\_ TEFLON PER ASTM-D-1710-02, TYPE 1, GRADE 1, CLASS B.

## 6. FINISH

BODY \_\_\_\_\_ PASSIVATE PER AMS-2700, TYPE 2, CLASS 4.

SPRING FINGERS \_\_\_\_\_ GOLD PER ASTM-B-488, TYPE I, CODE C, CLASS 0.75  
(.000030 MIN. THK.) OVER NICKEL per SAE-AMS-QQ-N-290  
CLASS 1 (.000050 MIN. THK.) OVER COPPER per AMS-2418  
(.000010 MIN. THK.)

CONTACT \_\_\_\_\_ GOLD PER ASTM-B-488, TYPE I, CODE C, CLASS 1.27  
(.000050 MIN. THK.) OVER NICKEL per SAE-AMS-QQ-N-290  
CLASS 1 (.000050 MIN. THK.) OVER COPPER per AMS-2418  
(.000010 MIN. THK.)

INSULATORS \_\_\_\_\_ N/A