

SPECIFICATION CONTROL DRAWING

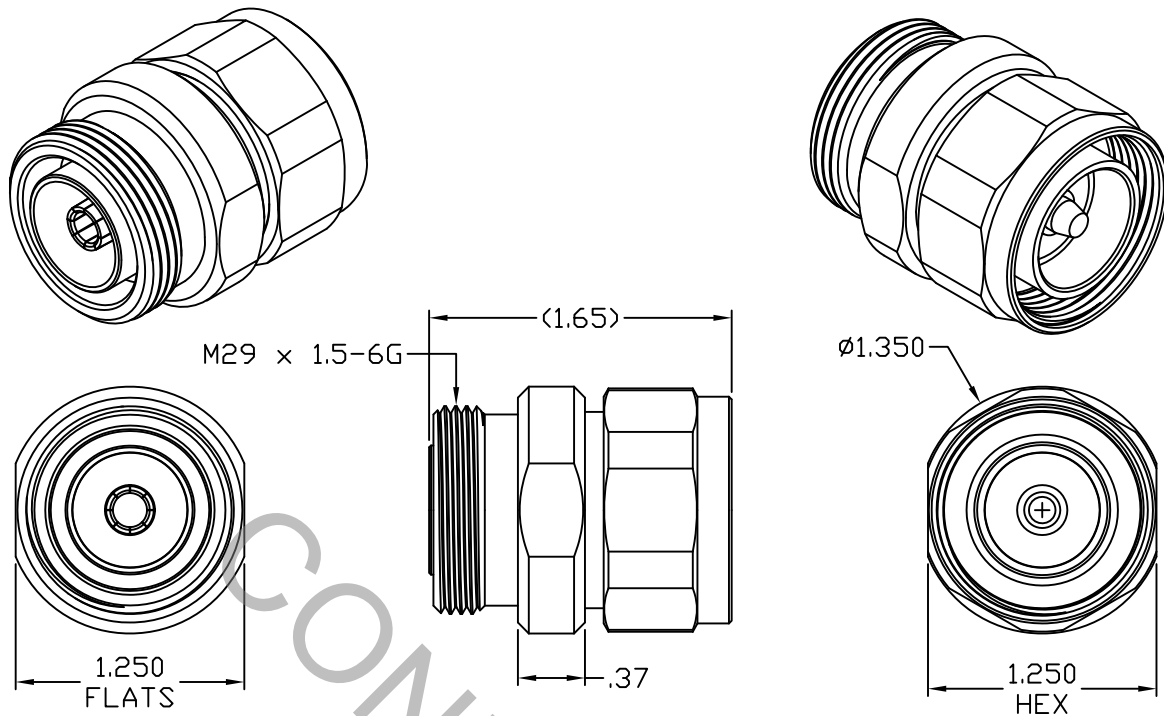

1. MATING INTERFACE DIMENSIONS Per IEC 169-4 (SOLID OUTER CONTACT).

2. ELECTRICAL

FREQUENCY RANGE GHz	_____	DC TO 6.0 GHz
VSWR (MAX.) *	_____	1.07 + .010 x FGHz
INSERTION LOSS (dB MAX.) *	_____	.05 dB x $\sqrt{\text{FGHz}}$
NOMINAL IMPEDANCE (OHMS)	_____	50
VOLTAGE RATING (MAX. VRMS)	_____	1,667
RF LEAKAGE (MIN. dB DOWN)	_____	-125 dB - FGHz
TEMPERATURE RATING (DEGREES CENTIGRADE)	_____	-65°C TO + 165°C
DIELECTRIC WITHSTANDING VOLTAGE (MAX. VRMS)	_____	5,000
INSULATION RESISTANCE (MIN. MEGOHMS)	_____	5,000
CONTACT RESISTANCE		
• CENTER CONTACT (MAX. MILLIOHMS)	_____	1.0
• OUTER CONTACT (MAX. MILLIOHMS)	_____	2.0

* TERMINATED IN A 50 OHM LOAD

RoHS
COMPLIANT

REV.	DCN NO.	DATE	APP.	DIMENSIONS ARE IN INCHES TOLERANCES			 HAVERHILL, MA 01835
AA	09-1433	5/20/09	DC	DECIMALS .X ± .030 .XX ± .010 .XXX ± .005	FRACTIONAL ± 1/64	ANGULAR X ° ± 1° 0' X ° X' ± 15'	
				DRAWN DC	DATE 5/20/09	TITLE 7/16 DIN PLUG TO 7/16 DIN JACK ADAPTER	
				APPROVED DC	DATE 5/20/09		
				CODE IDENT. 2J899	SHEET 1 OF 2	DWG. NO. 1100-4849-2150	

SPECIFICATION CONTROL DRAWING

3. MECHANICAL

CAPTIVATION-CENTER CONTACT

MAX AXIAL FORCE _____ 6.0 LBS.

MAX RADIAL TORQUE _____ N/A

CENTER CONTACT AXIAL FORCES

● INSERTION (MAX OUNCES) _____ FEMALE INTERFACE 64.0

● WITHDRAWAL (MIN. OUNCES) _____ FEMALE INTERFACE 4.0

CONNECTOR ENGAGEMENT/DISENGAGEMENT (MAX LBS.) _____ N/A

CONNECTOR DURABILITY (MIN. CYCLES) _____ 500

RECOMMENDED MATING TORQUE _____ 60 - 80 IN. LBS.

4. ENVIRONMENTAL

THERMAL SHOCK _____ MIL-STD-202, METHOD 107, COND. B (-65° c TO +165° c)

SHOCK _____ MIL-STD-202, METHOD 213, COND. I (100 G's)

VIBRATION _____ MIL-STD-202, METHOD 204, COND. D (20 G's)

MOISTURE RESISTANCE _____ MIL-STD-202, METHOD 106, LESS STEP 7b

CORROSION _____ MIL-STD-202, METHOD 101, COND. B (48 HOURS)

BAROMETRIC PRESSURE (ALTITUDE) _____ MIL-STD-202, METHOD 105, COND. C (70,000 FT.) (1,250 VRMS)

5. MATERIAL

BODY, OUTER CONTACT & COUPLING NUT _____ BRASS PER ASTM-B-16, TEMPER H02, ALLOY C36000.

CONTACTS & RETAINING RING _____ BERYLLIUM COPPER PER ASTM-B-196-90, COPPER ALLOY
No. UNS-C17300, TEMPER TD04.

INSULATOR _____ TEFLON PER ASTM-D-1710-02, TYPE 1, GRADE 1, CLASS B.

6. FINISH

BODY, OUTER CONTACT & COUPLING NUT _____ TRI-METAL ALLOY COMPRISED OF:
55%-60% COPPER, 25%-28% TIN & 14%-18% ZINC.
TOTAL PLATING .000100-.000200 THK.

CONTACT _____ TARNIBAN OVER SILVER PER QQ-S-365, TYPE 2, GRADE A
(.000300 MIN. THK.) OVER COPPER PER MIL-C-14550
(.000010 MIN. THK.)

INSULATOR & RETAINING RING _____ N/A