

# SPECIFICATION CONTROL DRAWING

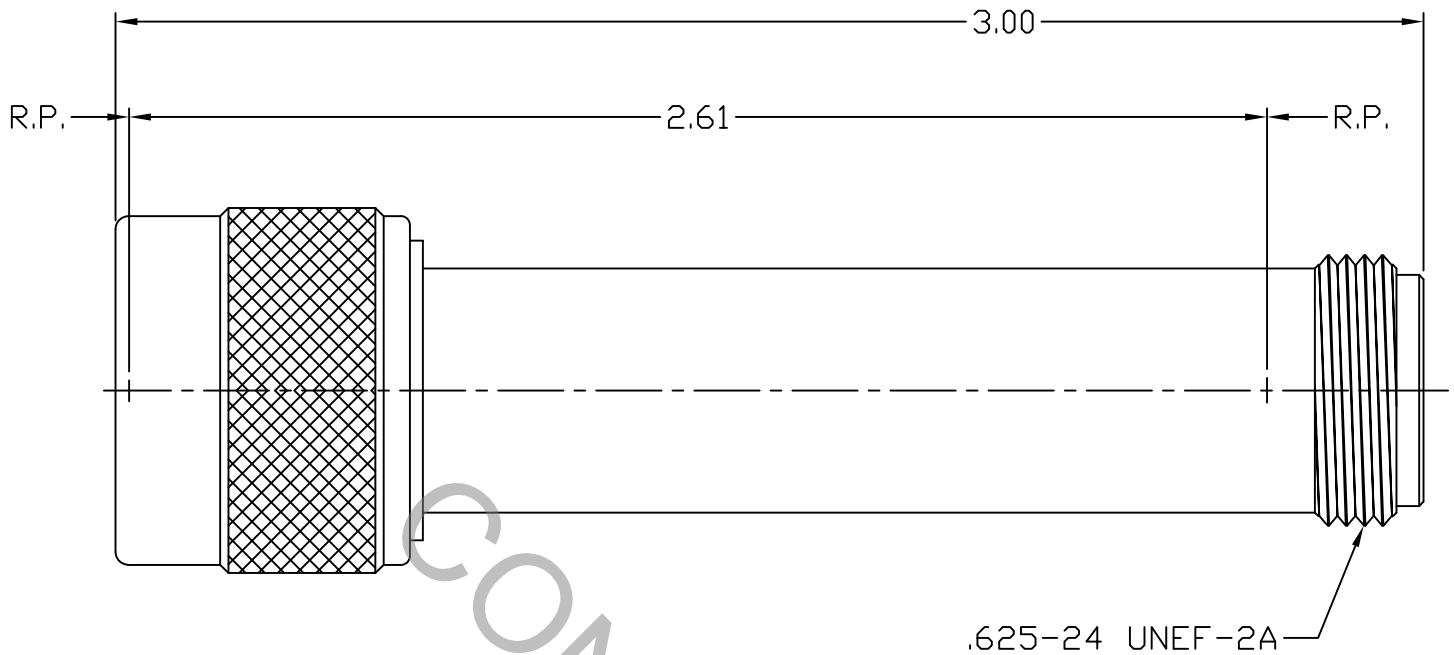

1. MATING INTERFACE DIMENSIONS MIL-STD-348 Fig. 304.2 ("N" JACK) AND MIL-STD-348 Fig. 304.1 ("N" PLUG) WITH SOLID OUTER.

## 2. ELECTRICAL

FREQUENCY RANGE GHz	DC TO 18.0 GHz
VSWR (MAX) *	1.08 + .008 x FGHz
INSERTION LOSS (dB MAX) *	.06 dB x $\sqrt{\text{FGHz}}$
NOMINAL IMPEDANCE (OHMS)	50
VOLTAGE RATING (MAX. VRMS)	500
RF LEAKAGE (MIN. dB DOWN)	-100 dB - FGHz
TEMPERATURE RATING (DEGREES CENTIGRADE)	-65°C TO + 165°C
DIELECTRIC WITHSTANDING VOLTAGE (MAX. VRMS)	1,500
INSULATION RESISTANCE (MIN. MEGOHMS)	5,000
CONTACT RESISTANCE	
• CENTER CONTACT (MAX. MILLIOHMS)	6.0
• OUTER CONTACT (MAX. MILLIOHMS)	2.0

\* TERMINATED IN A 50 OHM LOAD

**RoHS**  
COMPLIANT

REV.	DCN NO.	DATE	APP.	DIMENSIONS ARE IN INCHES TOLERANCES			HAVERHILL, MA 01835
AA	09-1063	1/22/09	TS	DECIMALS .X ± .030 .XX ± .010 .XXX ± .005	FRACTIONAL ± 1/64	ANGULAR X ° ± 1° 0' X ° X' ± 15'	
				DRAWN TS	DATE 1/22/09	TITLE "N" PLUG to "N" JACK EXTRA LONG ADAPTER	
				APPROVED DC	DATE 1/22/09		
				CODE IDENT. 2J899	SHEET 1 OF 2		
						DWG. NO. 1100-7475-6221	

# SPECIFICATION CONTROL DRAWING

## 3. MECHANICAL

### CAPTIVATION-CENTER CONTACT

MAX AXIAL FORCE \_\_\_\_\_ 6.0 LBS.

MAX RADIAL TORQUE \_\_\_\_\_ N/A

### CENTER CONTACT AXIAL FORCES

● INSERTION (MAX. OUNCES) \_\_\_\_\_ 32.0

● WITHDRAWAL (MIN. OUNCES) \_\_\_\_\_ 2.0

CONNECTOR ENGAGEMENT/DISENGAGEMENT (MAX. LBS.) \_\_\_\_\_ 2.0

CONNECTOR DURABILITY (MIN. CYCLES) \_\_\_\_\_ 500

RECOMMENDED MATING TORQUE \_\_\_\_\_ 15 - 18 IN. LBS.

## 4. ENVIRONMENTAL

TEMPERATURE CYCLING \_\_\_\_\_ MIL-STD-202, METHOD 102, COND. C ( -65° c TO + 165° c )

SHOCK \_\_\_\_\_ MIL-STD-202, METHOD 213, COND. I (100 G's)

VIBRATION \_\_\_\_\_ MIL-STD-202, METHOD 204, COND. D (20 G's)

MOISTURE RESISTANCE \_\_\_\_\_ MIL-STD-202, METHOD 106, LESS STEP 7b

CORROSION \_\_\_\_\_ MIL-STD-202, METHOD 101, COND. B (48 HOURS)

BAROMETRIC PRESSURE (ALTITUDE) \_\_\_\_\_ MIL-STD-202, METHOD 105, COND. C ( 70,000 FT. ) ( 375 VRMS )

## 5. MATERIAL

BODY & COUPLING NUT \_\_\_\_\_ STAINLESS STEEL PER ASTM A 582, TYPE 303, COND. A

CONTACT & RETAINING RING \_\_\_\_\_ BERYLLIUM COPPER PER ASTM B196/B, 196-03, COPPER ALLOY No. UNS-C17300, TEMPER TD04.

INSULATOR \_\_\_\_\_ TEFLON PER ASTM D 1710-02, TPYE 1, GRADE 1, CLASS B.

GASKET \_\_\_\_\_ SILICONE RUBBER PER ZZ-R-765

## 6. FINISH

BODY & COUPLING NUT \_\_\_\_\_ PASSIVATE PER AMS QQ-P-35 TYPE 2

CONTACT \_\_\_\_\_ GOLD PER ASTM-B-488, TYPE I, CODE C, CLASS 2.5  
(.000100 MIN. THK.) OVER NICKEL per QQ-N-290  
(.000050 MIN. THK.) OVER COPPER per MIL-C-14550  
(.000010 MIN. THK.)

INSULATOR, GASKET & RETAINING RING \_\_\_\_\_ N/A