

SPECIFICATION CONTROL DRAWING

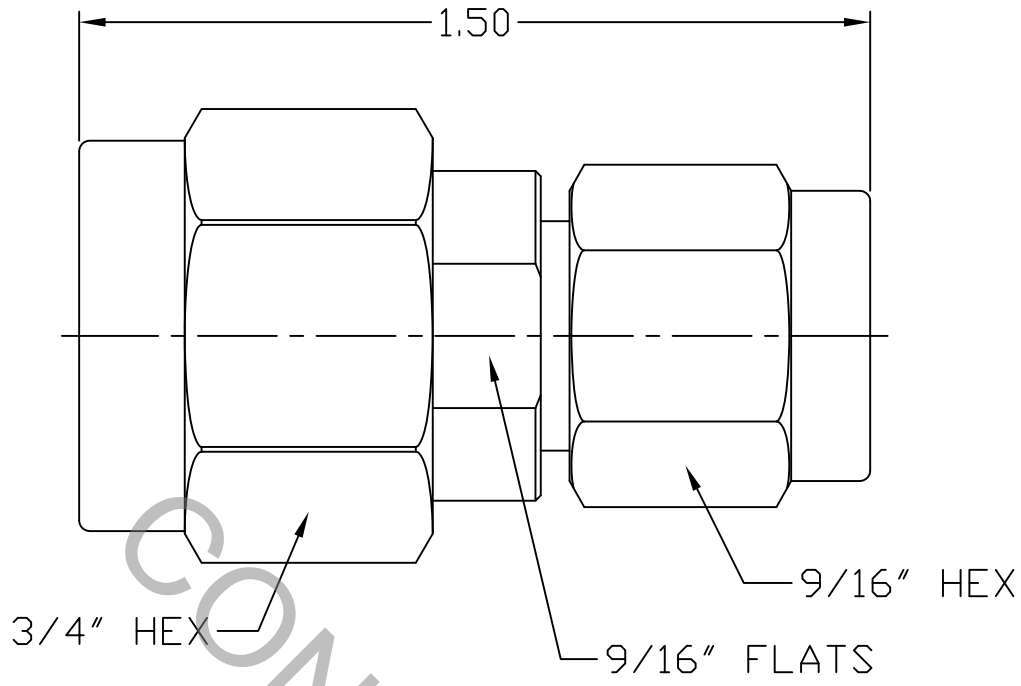

1. MATING INTERFACE DIMENSIONS MIL-STD-348 Fig. 304.1 (N PLUG)
WITH SOLID OUTER AND MIL-STD-348 Fig. 313.1 (TNC PLUG).

2. ELECTRICAL

FREQUENCY RANGE GHz	_____	DC TO 18.0 GHz
VSWR (MAX) *	_____	1.06 + .008 x FGHz
INSERTION LOSS (dB MAX) *	_____	.05 dB x $\sqrt{\text{FGHz}}$
NOMINAL IMPEDANCE (OHMS)	_____	50
VOLTAGE RATING (MAX. VRMS)	_____	500
RF LEAKAGE (MIN. dB DOWN)	_____	-100 dB - FGHz
TEMPERATURE RATING (DEGREES CENTIGRADE)	_____	-65°C TO + 165°C
DIELECTRIC WITHSTANDING VOLTAGE (MAX. VRMS)	_____	1,500
INSULATION RESISTANCE (MIN. MEGOHMS)	_____	5,000
CONTACT RESISTANCE		
• CENTER CONTACT (MAX. MILLIOHMS)	_____	6.0
• OUTER CONTACT (MAX. MILLIOHMS)	_____	2.0

* TERMINATED IN A 50 OHM LOAD

RoHS
COMPLIANT

This Document contains proprietary and confidential information.

REV.	DCN NO.	DATE	APP.	DIMENSIONS ARE IN INCHES TOLERANCES			 HAVERHILL, MA 01835
AA	06-1974	8/10/06	DC	DECIMALS	FRACTIONAL	ANGULAR	
AB	15-1360	3/11/15	TS	.X ± .030 .XX ± .010 .XXX ± .005	±/64	X ° ± 1 0' X ° X' ± 15'	TITLE N PLUG TNC PLUG ADAPTER
				DRAWN DC	DATE 8/10/06		
				APPROVED DC	DATE 8/10/06		
				CODE IDENT. 2J899	SHEET 1 OF 2	DWG. NO. 1100-7484-6250	

SPECIFICATION CONTROL DRAWING

3. MECHANICAL

CAPTIVATION-CENTER CONTACT

MAX AXIAL FORCE _____ 4.5 LBS.

MAX RADIAL TORQUE _____ N/A

CENTER CONTACT AXIAL FORCES

● INSERTION (MAX OUNCES) _____ N/A

● WITHDRAWAL (MIN. OUNCES) _____ N/A

CONNECTOR ENGAGEMENT/DISENGAGEMENT (MAX LBS.) _____ 2.0

CONNECTOR DURABILITY (MIN. CYCLES) _____ 500

RECOMMENDED MATING TORQUE _____ 18 - 20 IN. LBS.

4. ENVIRONMENTAL

TEMPERATURE CYCLING _____ MIL-STD-202, METHOD 102, COND. C (-65° c TO +165° c)

SHOCK _____ MIL-STD-202, METHOD 213, COND. I (100 G's)

VIBRATION _____ MIL-STD-202, METHOD 204, COND. D (20 G's)

MOISTURE RESISTANCE _____ MIL-STD-202, METHOD 106, LESS STEP 7b

CORROSION _____ MIL-STD-202, METHOD 101, COND. B (48 HOURS)

BAROMETRIC PRESSURE (ALTITUDE) _____ MIL-STD-202, METHOD 105, COND. C (70,000 FT.) (375 VRMS)

5. MATERIAL

BODY & COUPLING NUTS _____ STAINLESS STEEL PER AMS 5640, TYPE 303, COND. A

CONTACT & RETAINING RINGS _____ BERYLLIUM COPPER PER ASTM B196/B, 196M-03, COPPER ALLOY No. UNS-C17300, TEMPER TD04.

INSULATORS _____ TEFLON PER ASTM D 1710-12, TYPE 1, GRADE 1, CLASS B.

GASKETS _____ SILICONE RUBBER PER ZZ-R-765

6. FINISH

BODY & COUPLING NUTS _____ PASSIVATE PER AMS 2700 TYPE 2, CLASS 4

CONTACT _____ GOLD PER ASTM-B-488, TYPE I, CODE C, CLASS 1.25
(.000050 MIN. THK.) OVER NICKEL PER SAE AMS QQ-N-290, CLASS 1
(.000050 MIN. THK.) OVER COPPER PER AMS 2418 (.000010 MIN. THK.)

INSULATORS, GASKETS & RETAINING RINGS _____ N/A