

SPECIFICATION CONTROL DRAWING

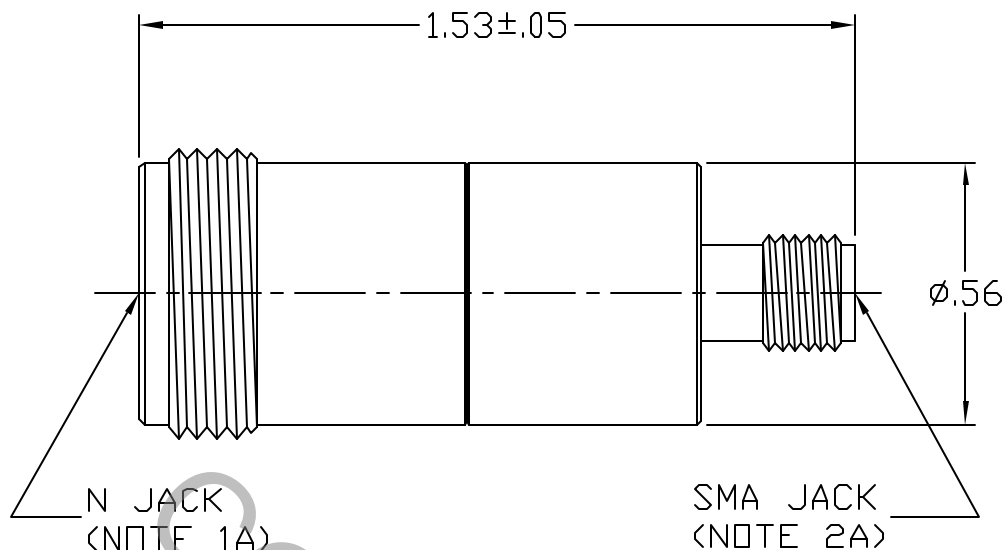

1. MATING
- 1A. INTERFACE DIMENSIONS PER MIL-STD-348-304.2 N SOCKET CONTACT.
 - 2A. INTERFACE DIMENSIONS PER MIL-STD-348-310.2 SMA SOCKET CONTACT.

2. ELECTRICAL

FREQUENCY RANGE GHz	DC TO 18.0 GHz.
VSWR (MAX) *	1.25:1
INSERTION LOSS (dB MAX)	.040 dB x \sqrt{FGHz} .
NOMINAL IMPEDANCE (OHMS)	50
VOLTAGE RATING (MAX VRMS)	330
RF LEAKAGE (MIN. dB DOWN)	60 dB - FGHz.
TEMPERATURE RATING (DEGREES CENTIGRADE)	-65°C TO +165°C
DIELECTRIC WITHSTANDING VOLTAGE (MAX. VRMS)	1,000
INSULATION RESISTANCE (MIN. MEGOHMS)	10,000
CONTACT RESISTANCE	
• CENTER CONTACT (MAX. MILLIOHMS)	4.5
• OUTER CONTACT (MAX. MILLIOHMS)	2.0

* TERMINATED IN A 50 OHM LOAD

REV.	DCN NO.	DATE	APP.	DIMENSIONS ARE IN INCHES TOLERANCES		 HAVERHILL, MA. 01835
AA	03-2355	10/30/03	DC	DECIMALS $X \pm .030$ $XX \pm .010$ $XXX \pm .005$	FRACTIONAL $\pm 1/84$	
				SURFACE ROUGHNESS 63 $\sqrt{MIL-STD 10}$.		
				DRAWN DC	DATE 10/30/03	TITLE N JACK TO SMA JACK ADAPTER
				APPROVED DC	DATE 10/30/03	
				CODE IDENT. 2J899	SHEET 1 OF 2	DWG. NO. 1100-7599-6250

SPECIFICATION CONTROL DRAWING

3. MECHANICAL

CAPTIVATION-CENTER CONTACT

- MIN. AXIAL FORCE _____ 6.0 LBS.
- MIN. RADIAL TORQUE _____ N/A

CENTER CONTACT AXIAL FORCES

- INSERTION (MAX. OUNCES) _____ 32.0
- WITHDRAWAL (MIN. OUNCES) _____ 2.0

CONNECTOR ENGAGEMENT/DISENGAGEMENT (MAX. IN. LBS.) _____ 2.0

CONNECTOR DURABILITY (MIN. CYCLES) _____ 1,000

RECOMMENDED MATING TORQUE (SMA PLUG) _____ 7 - 10 IN. LBS.

RECOMMENDED MATING TORQUE (N JACK) _____ 12 - 15 IN. LBS.

4. ENVIRONMENTAL

TEMPERATURE CYCLING _____ MIL-STD-202, METHOD 102, COND. C (-65 ° c TO + 165 ° c)

SHOCK _____ MIL-STD-202, METHOD 213, COND. I (100 G's)

VIBRATION _____ MIL-STD-202, METHOD 204, COND. D (20 G's)

MOISTURE RESISTANCE _____ MIL-STD-202, METHOD 106, LESS STEP 7b

CORROSION _____ MIL-STD-202, METHOD 101, COND. B (48 HOURS)

BAROMETRIC PRESSURE (ALTITUDE) _____ MIL-STD-202, METHOD 105, COND. C (70,000 FT.) (250 VRMS)

5. MATERIAL

BODY AND COUPLING NUT _____ STAINLESS STEEL PER AMS-5640, TYPE 303, COND. A

CONTACT AND RETAINING RING _____ BERYLLIUM COPPER PER QQ-C-530, ALLOY 173, COND. H.T.

INSULATOR _____ TEFLON PER MIL-P-18463 AND L-P-403, TYPE 1.

6. FINISH

BODY AND COUPLING NUT _____ PASSIVATE PER QQ-P-36A, TYPE 1.

CONTACT _____ GOLD PER ATSM B 488, TYPE I, CODE C, CLASS 2.5
(.000100 MIN.) OVER NICKEL PER QQ-N-290
(.000050 MIN. THK.) OVER COPPER PER MIL-C-14550
(.000010 MIN. THK.)

INSULATOR _____ N/A