

SPECIFICATION CONTROL DRAWING

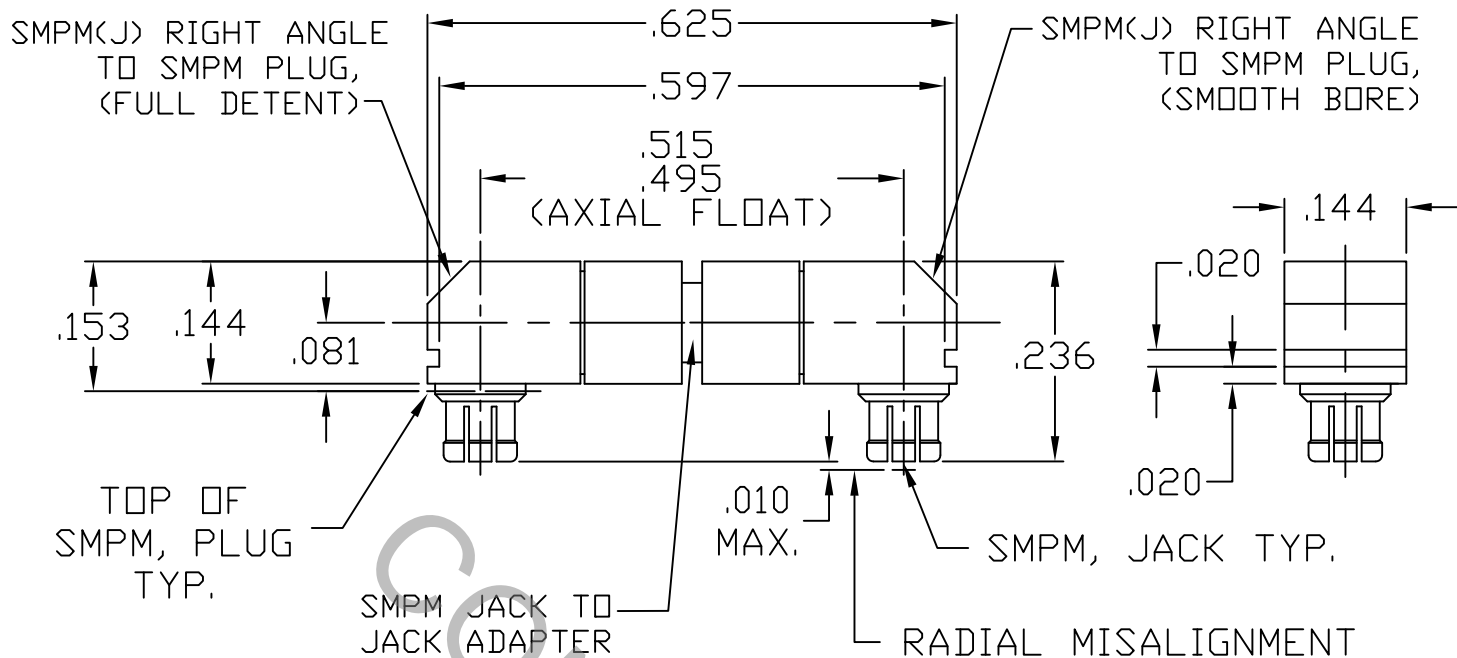

NOTE: SMPM, JACKS CAN ROTATE 360°

1. MATING INTERFACE DIMENSIONS PER MIL-STD-348A, Fig. 328.1 (SMPM, JACK)

2. ELECTRICAL

FREQUENCY RANGE GHz	DC TO 40.0 GHz.
VSWR (MAX) *	DC TO 26.5 GHz., 1.05 + .010 x FGHz. 26.5 TO 40 GHz., 1.10 + .015 x FGHz.
INSERTION LOSS (dB MAX.)*	DC TO 26.5 GHz., .060 dB x √FGHz. 26.5 TO 40.0 GHz., .080 dB x √FGHz.
NOMINAL IMPEDANCE (OHMS)	50
VOLTAGE RATING (MAX. VRMS)	250
RF LEAKAGE (MIN. dB DOWN)	-85 dB - FGHz.
TEMPERATURE RATING (DEGREES CENTIGRADE)	-65° c TO +150° c
DIELECTRIC WITHSTANDING VOLTAGE (MAX. VRMS)	500
INSULATION RESISTANCE (MIN. MEGOHMS)	2,500
CONTACT RESISTANCE	
• CENTER CONTACT (MAX. MILLIOHMS)	6.0
• OUTER CONTACT (MAX. MILLIOHMS)	2.0

RoHS
COMPLIANT

* TERMINATED IN A 50 OHM LOAD

REV.	DCN NO.	DATE	APP.	DIMENSIONS ARE IN INCHES TOLERANCES			 HAVERHILL, MA 01835
				DECIMALS .X ± .030 .XX ± .010 .XXX ± .005	FRACTIONAL ±1/64	ANGULAR X° ± 10' X° X' ± 15'	
AA	08-1043	1/10/08	DC				TITLE SMPM, JACK TO SMPM, JACK, RIGHT ANGLE HORSE SHOE ADAPTER
AB	08-1441	4/21/08	DC				
BA	10-2076	11/16/10	TS	DRAWN	TS	DATE 1/10/08	DWG. NO. 1101-3030-5460
BB	12-1629	8/1/12	DC	APPROVED	DC	DATE 1/10/08	
				CODE IDENT.	SHEET 1 OF 2		
				2J899			

SPECIFICATION CONTROL DRAWING

3. MECHANICAL

CAPTIVATION-CENTER CONTACT

- MIN. AXIAL FORCE _____ 4.5 LBS.
- MIN. RADIAL TORQUE _____ N/A

CONNECTOR ENGAGEMENT FORCES

- | | FULL DETENT | SMOOTH BORE |
|--------------------------------|-------------|-------------|
| ● INSERTION (MAX. LBS.) _____ | 6.5 | 1.5 |
| ● WITHDRAWAL (MIN. LBS.) _____ | 5.0 | 0.5 |

CONNECTOR DURABILITY (MIN. MATING) _____ 100 500

4. ENVIRONMENTAL

- TEMPERATURE CYCLING _____ MIL-STD-202, METHOD 102, COND. C (-65 ° c TO + 165 ° c)
- SHOCK _____ MIL-STD-202, METHOD 213, COND. I (100 G's)
- VIBRATION _____ MIL-STD-202, METHOD 204, COND. D (20 G's)
- MOISTURE RESISTANCE _____ MIL-STD-202, METHOD 106, LESS STEP 7b
- CORROSION _____ MIL-STD-202, METHOD 101, COND. B (48 HOURS)
- BAROMETRIC PRESSURE (ALTITUDE) _____ MIL-STD-202, METHOD 105, COND. C (70,000 FT.) (125 VRMS)

5. MATERIAL

- CONNECTOR BODY (SMPM, PLUG) _____ STAINLESS STEEL PER ASTM A 581, TYPE 303, COND. A.
- CONNECTOR BODY (SMPM, JACK) AND CENTER CONTACT _____ BERYLLIUM COPPER PER ASTM B196/B, 196M-03, COPPER ALLOY No. UNS C17300, TEMPER TD04.
- INSULATORS _____ TEFLON PER ASTM D 1710-02, TYPE 1, GRADE 1, CLASS B.

6. FINISH

- CONNECTOR BODY (SMPM, PLUG) _____ PASSIVATE PER AMS 2700, TYPE 2, CLASS 4.
- CONNECTOR BODY (SMPM, JACK) _____ GOLD PER ASTM B 488, TYPE 1, CODE C, CLASS 1.27
(.000050 MIN. THK.) OVER NICKEL PER SAE AMS QQ-N-290 CLASS 1
(.000100 MIN. THK.) OVER COPPER PER AMS 2418 (.000010 MIN. THK.)
- CENTER CONTACT _____ GOLD PER ASTM B 488, TYPE 1, CODE C, CLASS 1.27
(.000050 MIN. THK.) OVER NICKEL PER SAE AMS QQ-N-290 CLASS 1
(.000050 MIN. THK.) OVER COPPER PER AMS 2418 (.000010 MIN. THK.)
- INSULATORS _____ N/A