

# SPECIFICATION CONTROL DRAWING

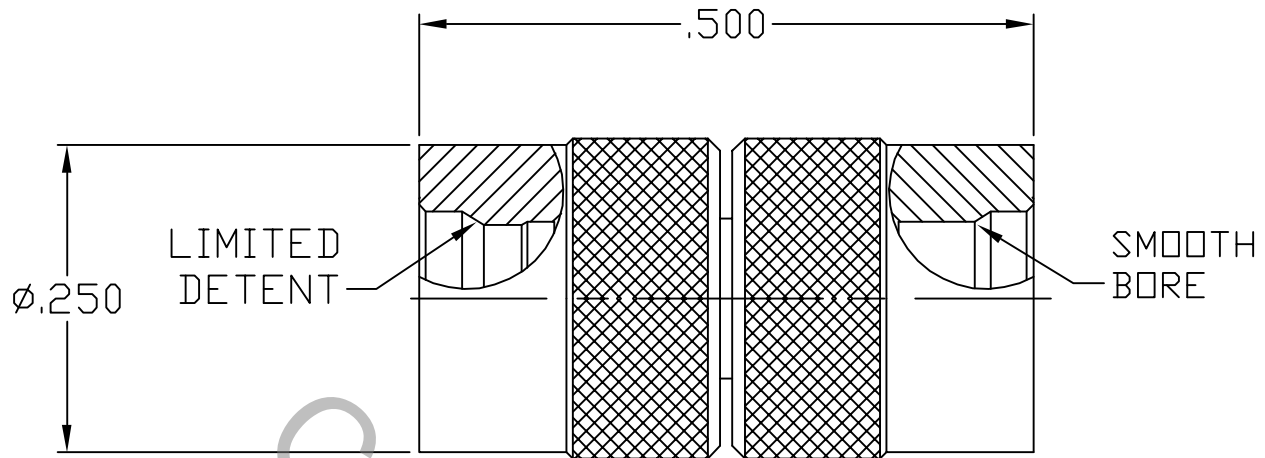

1. MATING INTERFACE DIMENSIONS Per MIL-STD-348  
Fig. 326.3 (SMP MALE LD) AND Fig. 326.4 (SMP MALE SB).

## 2. ELECTRICAL

FREQUENCY RANGE GHz	DC TO 40.0 GHz
VSWR (MAX.) *	1.09 + .015 x FGHz
INSERTION LOSS (dB MAX.) *	.050 dB x $\sqrt{\text{FGHz}}$
NOMINAL IMPEDANCE (OHMS)	50
VOLTAGE RATING (MAX. VRMS)	150
RF LEAKAGE (MIN. dB DOWN)	-85 dB - FGHz
TEMPERATURE RATING (DEGREES CENTIGRADE)	-65°c TO + 165°c
DIELECTRIC WITHSTANDING VOLTAGE (MAX. VRMS)	500
INSULATION RESISTANCE (MIN. MEGOHMS)	5,000
CONTACT RESISTANCE	
• CENTER CONTACT (MAX. MILLIOHMS)	3.0
• OUTER CONTACT (MAX. MILLIOHMS)	2.0

\* TERMINATED IN A 50 OHM LOAD

REV.	DCN NO.	DATE	APP.	DIMENSIONS ARE IN INCHES TOLERANCES			 HAVERHILL, MA 01835
AA	06-1962	8/8/06	DC	DECIMALS .X ± .030 .XX ± .010 .XXX ± .005	FRACTIONAL ± 1/64	ANGULAR X ° ± 1'0" X ° X' ± 15'	
				DRAWN DC	DATE 8/8/06	TITLE SMP MALE, LIMITED DETENT TO SMP MALE, SMOOTH BORE ADAPTER	
				APPROVED DC	DATE 8/8/06		
				CODE IDENT. 2J899	SHEET 1 OF 2	DWG. NO. 1107-2121-6251	

# SPECIFICATION CONTROL DRAWING

## 3. MECHANICAL

CAPTIVATION-CENTER CONTACT  
MAX AXIAL FORCE \_\_\_\_\_ 4.5 LBS.  
MAX RADIAL TORQUE \_\_\_\_\_ N/A  
CENTER CONTACT AXIAL FORCES  
● INSERTION (MAX OUNCES) \_\_\_\_\_ N/A  
● WITHDRAWAL (MIN. OUNCES) \_\_\_\_\_ N/A  
CONNECTOR ENGAGEMENT/DISENGAGEMENT (MAX IN. LBS.) — N/A  
CONNECTOR DURABILITY (MIN. CYCLES) \_\_\_\_\_ 500  
RECOMMENDED MATING TORQUE \_\_\_\_\_ N/A

## 4. ENVIRONMENTAL

TEMPERATURE CYCLING \_\_\_\_\_ MIL-STD-202, METHOD 102, COND. C ( -65° c TO +165° c )  
SHOCK \_\_\_\_\_ MIL-STD-202, METHOD 213, COND. I (100 G's)  
VIBRATION \_\_\_\_\_ MIL-STD-202, METHOD 204, COND. D (20 G's)  
MOISTURE RESISTANCE \_\_\_\_\_ MIL-STD-202, METHOD 106, LESS STEP 7b  
CORROSION \_\_\_\_\_ MIL-STD-202, METHOD 101, COND. B (48 HOURS)  
BAROMETRIC PRESSURE (ALTITUDE) — MIL-STD-202, METHOD 105, COND. C ( 70,000 FT. ) ( 125 VRMS )

## 5. MATERIAL

BODIES \_\_\_\_\_ STAINLESS STEEL PER AMS 5640, TYPE 303, COND. A  
CONTACT \_\_\_\_\_ BERYLLIUM COPPER PER ASTM B196-90, COPPER ALLOY  
No. UNS-C17300, TEMPER TD04.  
INSULATOR \_\_\_\_\_ TEFLON PER ASTM D 4894-91.

## 6. FINISH

BODY \_\_\_\_\_ PASSIVATE PER AMS QQ-P-35, TYPE 2.  
CONTACT \_\_\_\_\_ GOLD PER ASTM-B-488, TYPE I, CODE C, CLASS 2.5  
(.000100 MIN. THK.) OVER NICKEL per QQ-N-290  
(.000050 MIN. THK.) OVER COPPER per MIL-C-14550  
(.000010 MIN. THK.)  
INSULATOR \_\_\_\_\_ N/A