

SPECIFICATION CONTROL DRAWING

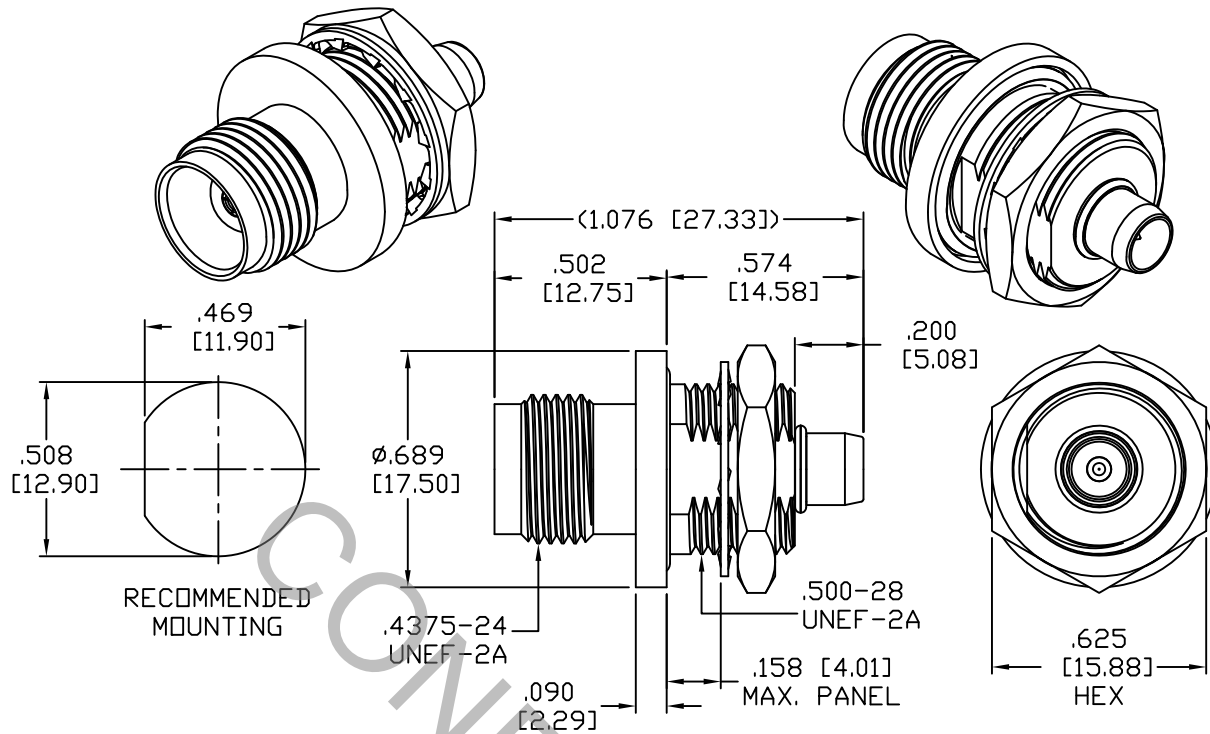

1. MATING INTERFACE DIMENSIONS Per MIL-STD-348 Fig. 303.2 (TNC JACK) AND MIL-STD-348 Fig. 321.1 (BMA PLUG).

2. ELECTRICAL

FREQUENCY RANGE GHz	_____	DC TO 18.0 GHz
VSWR (MAX.) *	_____	1.10 + .010 x FGHz
INSERTION LOSS (dB MAX.) *	_____	.06 dB x $\sqrt{\text{FGHz}}$
NOMINAL IMPEDANCE (OHMS)	_____	50
VOLTAGE RATING (MAX. VRMS)	_____	335
RF LEAKAGE (MIN. dB DOWN)	_____	-100 dB - FGHz
TEMPERATURE RATING (DEGREES CENTIGRADE)	_____	-65°C TO + 165°C
DIELECTRIC WITHSTANDING VOLTAGE (MAX. VRMS)	_____	1,000
INSULATION RESISTANCE (MIN. MEGOHMS)	_____	5,000
CONTACT RESISTANCE		
• CENTER CONTACT (MAX. MILLIOHMS)	_____	6.0
• OUTER CONTACT (MAX. MILLIOHMS)	_____	2.0

* TERMINATED IN A 50 OHM LOAD

RoHS
COMPLIANT

REV.	DCN NO.	DATE	APP.	DIMENSIONS ARE IN INCHES TOLERANCES				 HAVERHILL, MA 01835	
				DECIMALS	FRACTIONAL	ANGULAR			
AA	10-1702	8/3/10	TS	.X ± .030 .XX ± .010 .XXX ± .005	± 1/64	X ° ± 1° 0' X ° X' ± 15'			
AB	10-1735	8/11/10	DC				TITLE		
AC	11-1186	2/28/11	BC	DRAWN	TS	DATE	8/3/10	TNC JACK TO BMA PLUG BULKHEAD ADAPTER	
				APPROVED	DC	DATE	8/3/10		
				CODE IDENT.			SHEET 1 OF 2	DWG. NO.	1110-2885-6200
				2J899					

SPECIFICATION CONTROL DRAWING

3. MECHANICAL

CAPTIVATION-CENTER CONTACT

MAX AXIAL FORCE _____ 4.5 LBS.

MAX RADIAL TORQUE _____ N/A

CENTER CONTACT AXIAL FORCES

● INSERTION (MAX OUNCES) _____ INTERFACE 32.0

● WITHDRAWAL (MIN. OUNCES) _____ INTERFACE 2.0

CONNECTOR ENGAGEMENT/DISENGAGEMENT (MAX LBS.) _____ 2.0

CONNECTOR DURABILITY (MIN. CYCLES) _____ 500

RECOMMENDED MATING TORQUE _____ 15 - 20 IN. LBS.

RECOMMENDED MOUNTING TORQUE _____ 30 - 35 IN. LBS.

4. ENVIRONMENTAL

TEMPERATURE CYCLING _____ MIL-STD-202, METHOD 107, COND. C (-65° c TO + 165° c)

SHOCK _____ MIL-STD-202, METHOD 213, COND. I (100 G's)

VIBRATION _____ MIL-STD-202, METHOD 204, COND. D (20 G's)

MOISTURE RESISTANCE _____ MIL-STD-202, METHOD 106, LESS STEP 7b

CORROSION _____ MIL-STD-202, METHOD 101, COND. B (48 HOURS)

BAROMETRIC PRESSURE (ALTITUDE) _____ MIL-STD-202, METHOD 105, COND. C (70,000 FT.) (250 VRMS)

DESIGNED TO MEET OR EXCEED IP68 FOR DUST AND WATER SUBMERSION.

5. MATERIAL

BODY & HEX NUT _____ STAINLESS STEEL PER ASTM-A-582, TYPE 303, COND. A

LOCKWASHER _____ STAINLESS STEEL PER ASTM-A-479, TYPE 304

CONTACT _____ BERYLLIUM COPPER PER ASTM-B-196/B, 196M-03, COPPER ALLOY No. UNS-C17300, TEMPER TD04.

INSULATOR _____ TEFLON PER ASTM-D-1710-02, TYPE 1, GRADE 1, CLASS B.

FLANGE & BMA O-RING _____ FLOUROSILICONE PER MIL-R-25988, TYPE 1, CLASS 1, GRADE 60/3.

6. FINISH

BODY, LOCKWASHER & HEX NUT _____ PASSIVATE PER AMS-2700, TYPE 2, CLASS 4.

CONTACT _____ GOLD PER ASTM-B-488, TYPE I, CODE C, CLASS 1.27 (.000050 MIN. THK.) OVER NICKEL PER SAE-AMS-QQ-N-290 CLASS 1 (.000050 MIN. THK.) OVER COPPER PER AMS-2418 (.000010 MIN. THK.)

INSULATOR & O-RINGS _____ N/A