

SPECIFICATION CONTROL DRAWING

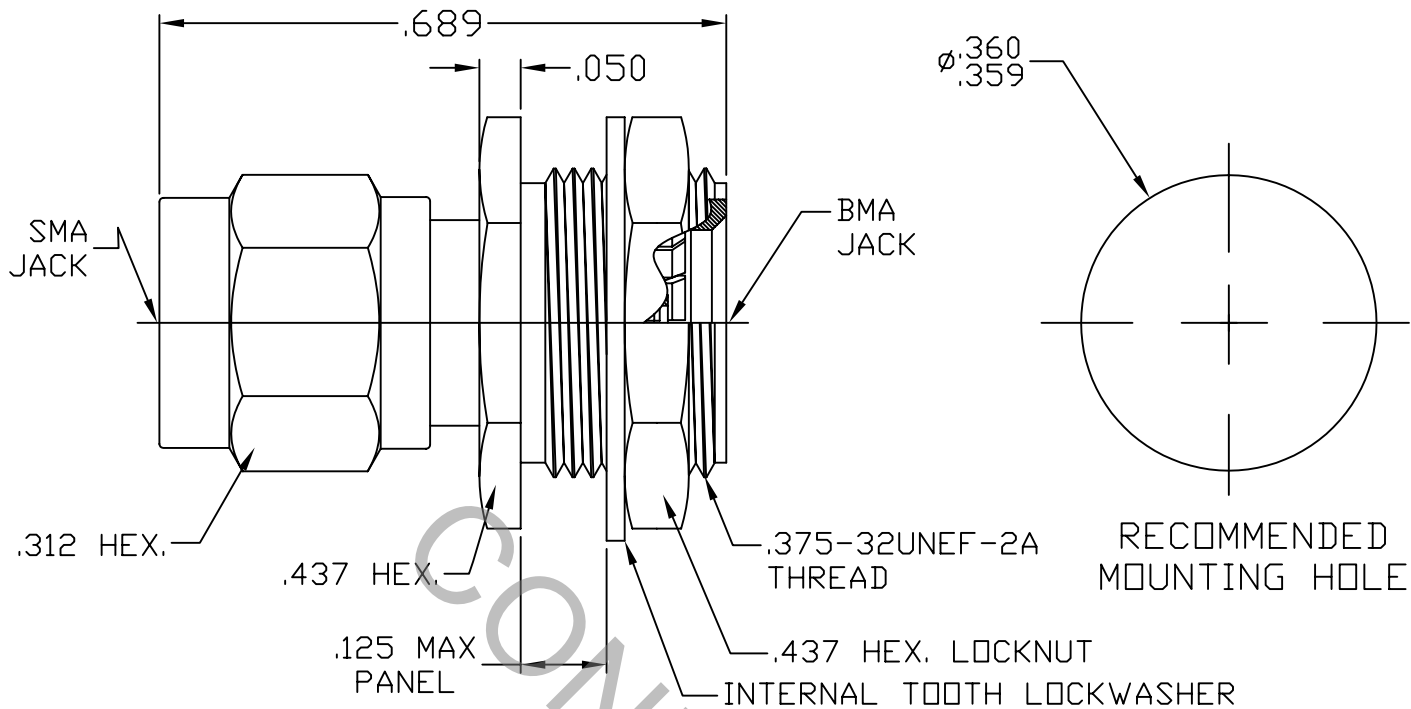

1. MATING INTERFACE DIMENSIONS MIL-STD-348 Fig. 310.1 (SMA PLUG) AND Fig. 321.2 (BMA JACK).

2. ELECTRICAL

FREQUENCY RANGE GHz	_____	DC TO 20.0 GHz
VSWR (MAX) *	_____	1.05 + .007 x FGHz
INSERTION LOSS (dB MAX) *	_____	.035 dB x $\sqrt{\text{FGHz}}$
NOMINAL IMPEDANCE (OHMS)	_____	50
VOLTAGE RATING (MAX. VRMS)	_____	250
RF LEAKAGE (MIN. dB DOWN)	_____	100 dB - FGHz
TEMPERATURE RATING (DEGREES CENTIGRADE)	_____	-65°C TO + 165°C
DIELECTRIC WITHSTANDING VOLTAGE (MAX. VRMS)	_____	1,000
INSULATION RESISTANCE (MIN. MEGOHMS)	_____	10,000
CONTACT RESISTANCE		
• CENTER CONTACT (MAX. MILLIOHMS)	_____	6.0
• OUTER CONTACT (MAX. MILLIOHMS)	_____	2.0

* TERMINATED IN A 50 OHM LOAD

REV.	DCN NO.	DATE	APP.	DIMENSIONS ARE IN INCHES TOLERANCES			 HAVERHILL, MA 01835
AA	06-1551			DECIMALS	FRACTIONAL	ANGULAR	
				.X ± .030 .XX ± .010 .XXX ± .005	±/64	X ° ± 1 0' X ° X' ± 15'	TITLE SMA, PLUG TO BMA, JACK BULKHEAD ADAPTER
				DRAWN TS	DATE	4/26/06	
				APPROVED DC	DATE	4/26/06	
				CODE IDENT. 2J899	SHEET 1 OF 2	DWG. NO. 1110-6798-6250	

SPECIFICATION CONTROL DRAWING

3. MECHANICAL

CAPTIVATION-CENTER CONTACT

MAX AXIAL FORCE _____ 6.0 LBS.

MAX RADIAL TORQUE _____ N/A

CENTER CONTACT AXIAL FORCES

● INSERTION (MAX. OUNCES) _____ SMA AND BMA INTERFACE 32.0

● WITHDRAWAL (MIN. OUNCES) _____ SMA AND BMA INTERFACE 2.0

CONNECTOR ENGAGEMENT/DISENGAGEMENT (MAX. IN. LBS.) — BMA 3.0 / 1.5

CONNECTOR DURABILITY (MIN. CYCLES) _____ 500

RECOMMENDED MATING TORQUE _____ SMA 7 - 10 IN. LBS.

4. ENVIRONMENTAL

TEMPERATURE CYCLING _____ MIL-STD-202, METHOD 102, COND. C (-65° c TO + 200° c)

SHOCK _____ MIL-STD-202, METHOD 213, COND. I (100 G's)

VIBRATION _____ MIL-STD-202, METHOD 204, COND. D (20 G's)

MOISTURE RESISTANCE _____ MIL-STD-202, METHOD 106, LESS STEP 7b

CORROSION _____ MIL-STD-202, METHOD 101, COND. B (48 HOURS)

BAROMETRIC PRESSURE (ALTITUDE) — MIL-STD-202, METHOD 105, COND. C (70,000 FT.) (190 VRMS)

5. MATERIAL

BODY, COUPLING NUT, LOCKWASHER AND LOCKNUT _____ STAINLESS STEEL PER ASTM A581, TYPE 303, COND. A

CENTER CONTACT, SPRING FINGERS AND RETAINING RING _____ BERYLLIUM COPPER PER ASTM B196-90, COPPER ALLOY No. UNS-C17300, TEMPER TD04.

CENTER CONTACT HOOD _____ BRASS PER ASTM B16, TEMPER H02, ALLOY C36000.

GASKET _____ SILICONE RUBBER

INSULATOR _____ TEFLON PER ASTM D 1710.

6. FINISH

BODY, COUPLING NUT, LOCKWASHER AND LOCKNUT _____ PASSIVATE PER AMS QQ-P-35, TYPE 2.

CENTER CONTACT ASSEMBLY AND SPRING FINGERS _____ GOLD PER ASTM B 488, TYPE II, CODE C, CLASS 2.5 (.000100 MIN. THK.) OVER NICKEL per QQ-N-290 (.000050 MIN. THK.) OVER COPPER per MIL-C-14550 (.000010 MIN. THK.)

INSULATOR, GASKET AND RETAINING RING _____ N/A