

SPECIFICATION CONTROL DRAWING

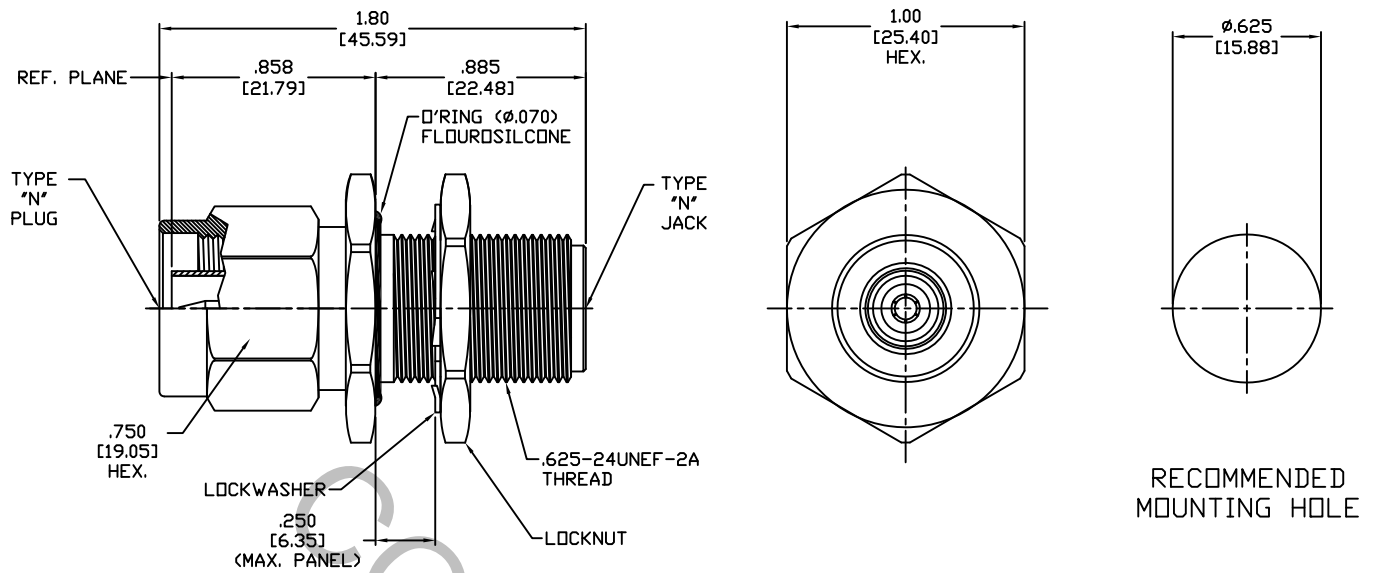

1. MATING INTERFACE DIMENSIONS Per MIL-STD-348 Fig. 304.2 (N JACK).

2. ELECTRICAL

FREQUENCY RANGE GHz	_____	DC TO 10.0 GHz
VSWR (MAX.) *	_____	1.05 + .010 x FGHz
INSERTION LOSS (dB MAX.) *	_____	.06 dB x √FGHz
NOMINAL IMPEDANCE (OHMS)	_____	50
VOLTAGE RATING (MAX. VRMS)	_____	333
RF LEAKAGE (MIN. dB DOWN)	_____	-100 dB - FGHz
TEMPERATURE RATING (DEGREES CENTIGRADE)	_____	-65°C TO + 165°C
DIELECTRIC WITHSTANDING VOLTAGE (MAX. VRMS)	_____	1,000
INSULATION RESISTANCE (MIN. MEGOHMS)	_____	10,000
CONTACT RESISTANCE		
• CENTER CONTACT (MAX. MILLIOHMS)	_____	3.0
• OUTER CONTACT (MAX. MILLIOHMS)	_____	2.0

* TERMINATED IN A 50 OHM LOAD

RoHS
COMPLIANT

This Document contains proprietary and confidential information.

REV.	DCN NO.	DATE	APP.	DIMENSIONS ARE IN INCHES			 Haverhill, MA 01835
				DECIMALS	FRACTIONAL	ANGULAR	
AA	15-2149	8/12/15	TS	.X ± .030	± 1/64	X ° ± 1° 0'	TITLE N JACK, BULKHEAD, FRONT MOUNT, SOLDER CLAMP, φ.141 SEMI-RIGID, EMI GASKET
AB	15-2152	8/13/15	TS	.XX ± .010		X ° X' ± 15'	
				.XXX ± .005			
AC	15-2209	8/26/15	TS	DRAWN TS	DATE 8/12/15		
AD	18-1598	5/30/18	TS	APPROVED DC	DATE 8/12/15		
				CODE IDENT.	SHEET 1 OF 2	DWG. NO. 1110-7475-3200	
				2J899			

SPECIFICATION CONTROL DRAWING

3. MECHANICAL

CAPTIVATION-CENTER CONTACT

MIN. AXIAL FORCE _____ 4.5 LBS.

MIN. RADIAL TORQUE _____ N/A

CENTER CONTACT AXIAL FORCES

● INSERTION (MAX. OUNCES) _____ INTERFACE 40.0

● WITHDRAWAL (MIN. OUNCES) _____ INTERFACE 2.0

CONNECTOR ENGAGEMENT/DISENGAGEMENT (MAX. LBS.) _____ 2.0

CONNECTOR DURABILITY (MIN. CYCLES) _____ 500

RECOMMENDED MATING TORQUE _____ 17 - 20 IN. LBS.

RECOMMENDED MOUNTING TORQUE _____ 30 - 35 IN. LBS.

4. ENVIRONMENTAL

TEMPERATURE CYCLING _____ MIL-STD-202, METHOD 107, COND. C (-65° c TO + 165° c)

SHOCK _____ MIL-STD-202, METHOD 213, COND. I (100 G's)

VIBRATION _____ MIL-STD-202, METHOD 204, COND. D (20 G's)

MOISTURE RESISTANCE _____ MIL-STD-202, METHOD 106, LESS STEP 7b

CORROSION _____ MIL-STD-202, METHOD 101, COND. B (48 HOURS)

BAROMETRIC PRESSURE (ALTITUDE) _____ MIL-STD-202, METHOD 105, COND. C (70,000 FT.) (250 VRMS)

5. MATERIAL

BODY, COUPLING NUT & HEX NUT _____ STAINLESS STEEL PER ASTM-A-479, TYPE 316L

CONTACT & RETAINING RING _____ BERYLLIUM COPPER PER ASTM-B-196/B, 196M-03, COPPER ALLOY No. UNS-C17300, TEMPER TD04.

INSULATOR _____ TEFLON PER ASTM-D-1710-02, TYPE 1, GRADE 1, CLASS B.

O-RING _____ FLOUROSILCONE PER MIL-R-25988. TYPE 1, CLASS 1 GRADE 60/3

GASKET _____ SILICONE RUBBER

LOCKWASHER _____ 400 SERIES STAINLESS STEEL

6. FINISH

BODY, COUPLING NUT, LOCKWASHER & HEX NUT _____ PASSIVATE PER AMS-2700, TYPE 2, CLASS 4.

CONTACT _____ GOLD PER ASTM-B-488, TYPE II, CODE C, CLASS 1.27
(.000050 MIN. THK.) OVER NICKEL PER SAE-AMS-QQ-N-290
CLASS 1 (.000050 MIN. THK.) OVER COPPER PER AMS-2418
(.000010 MIN. THK.)

INSULATOR, RETAINING RING, GASKET & O-RING _____ N/A