

# SPECIFICATION CONTROL DRAWING

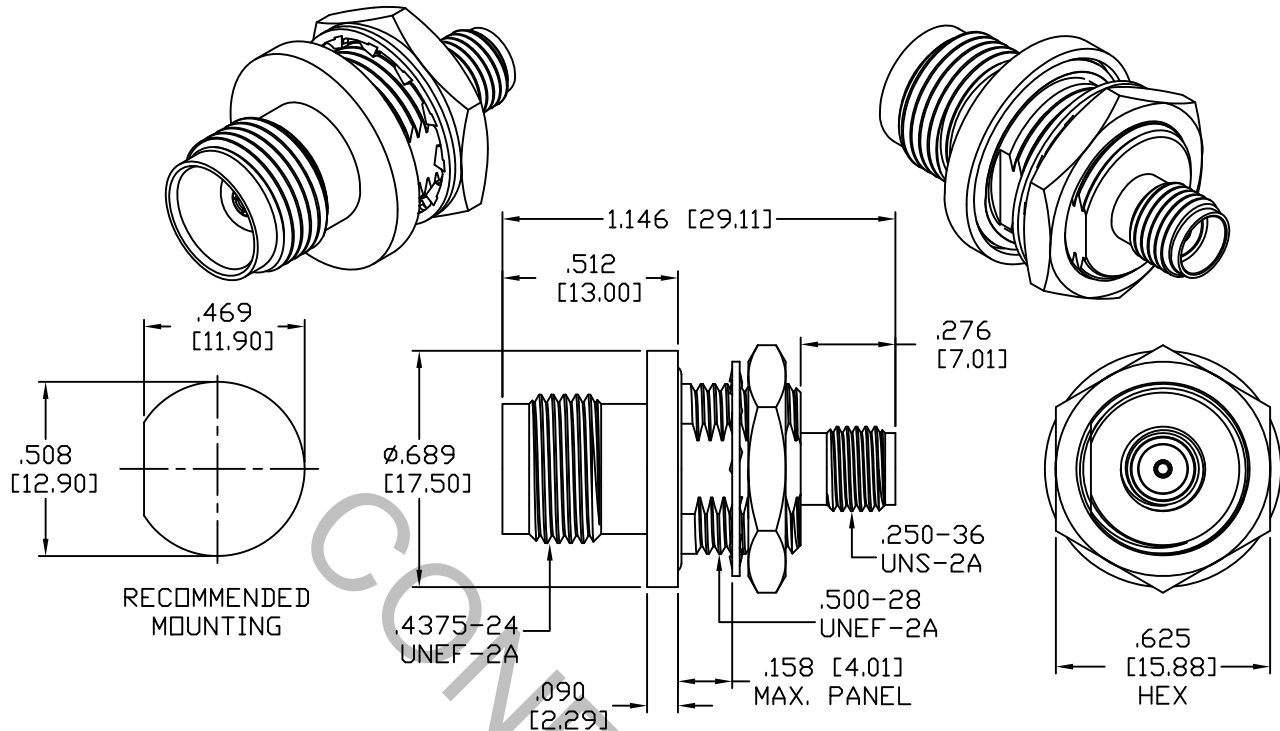

1. MATING INTERFACE DIMENSIONS Per MIL-STD-348 Fig. 303.2 (TNC JACK) AND MIL-STD-348 Fig. 310.2 (SMA JACK).

## 2. ELECTRICAL

FREQUENCY RANGE GHz	_____	DC TO 18.0 GHz
VSWR (MAX) *	_____	1.10 + .010 x FGHz
INSERTION LOSS (dB MAX) *	_____	.06 dB x $\sqrt{\text{FGHz}}$
NOMINAL IMPEDANCE (OHMS)	_____	50
VOLTAGE RATING (MAX. VRMS)	_____	335
RF LEAKAGE (MIN. dB DOWN)	_____	-100 dB - FGHz
TEMPERATURE RATING (DEGREES CENTIGRADE)	_____	-65°C TO + 165°C
DIELECTRIC WITHSTANDING VOLTAGE (MAX. VRMS)	_____	1,000
INSULATION RESISTANCE (MIN. MEGOHMS)	_____	5,000
CONTACT RESISTANCE		
• CENTER CONTACT (MAX. MILLIOHMS)	_____	6.0
• OUTER CONTACT (MAX. MILLIOHMS)	_____	2.0

\* TERMINATED IN A 50 OHM LOAD

**RoHS**  
COMPLIANT

This Document contains proprietary and confidential information.

REV.	DCN NO.	DATE	APP.	DIMENSIONS ARE IN INCHES TOLERANCES			 HAVERHILL, MA 01835
				DECIMALS	FRACTIONAL	ANGULAR	
				.X ± .030 .XX ± .010 .XXX ± .005	± 1/64	X ° ± 1° 0' X ° X' ± 15'	
AA	10-1691	7/30/10	TS				TITLE TNC JACK TO SMA JACK BULKHEAD ADAPTER
AB	10-1737	8/12/10	DC	DRAWN	TS	DATE 7/30/10	
AC	18-1617	6/5/18	TS	APPROVED	DC	DATE 7/30/10	
				CODE IDENT.	SHEET 1 OF 2		DWG. NO. 1110-8599-6202
				2J899			

# SPECIFICATION CONTROL DRAWING

## 3. MECHANICAL

### CAPTIVATION-CENTER CONTACT

MAX AXIAL FORCE \_\_\_\_\_ 4.5 LBS.

MAX RADIAL TORQUE \_\_\_\_\_ N/A

### CENTER CONTACT AXIAL FORCES

● INSERTION (MAX OUNCES) \_\_\_\_\_ INTERFACE 32.0

● WITHDRAWAL (MIN. OUNCES) \_\_\_\_\_ INTERFACE 2.0

CONNECTOR ENGAGEMENT/DISENGAGEMENT (MAX LBS.) \_\_\_\_\_ 2.0

CONNECTOR DURABILITY (MIN. CYCLES) \_\_\_\_\_ 500

RECOMMENDED MATING TORQUE \_\_\_\_\_ TNC, 17 - 20 IN. LBS., SMA 7 - 10 IN. LBS.

RECOMMENDED MOUNTING TORQUE \_\_\_\_\_ 30 - 35 IN. LBS.

## 4. ENVIRONMENTAL

TEMPERATURE CYCLING \_\_\_\_\_ MIL-STD-202, METHOD 107, COND. C ( -65° c TO + 165° c )

SHOCK \_\_\_\_\_ MIL-STD-202, METHOD 213, COND. I (100 G's)

VIBRATION \_\_\_\_\_ MIL-STD-202, METHOD 204, COND. D (20 G's)

MOISTURE RESISTANCE \_\_\_\_\_ MIL-STD-202, METHOD 106, LESS STEP 7b

CORROSION \_\_\_\_\_ MIL-STD-202, METHOD 101, COND. B (48 HOURS)

BAROMETRIC PRESSURE (ALTITUDE) \_\_\_\_\_ MIL-STD-202, METHOD 105, COND. C ( 70,000 FT. ) ( 250 VRMS )

DESIGNED TO MEET OR EXCEED IP68 FOR DUST AND WATER SUBMERSION.

## 5. MATERIAL

BODY & HEX NUT \_\_\_\_\_ STAINLESS STEEL PER ASTM-A-582, TYPE 303, COND. A

LOCKWASHER \_\_\_\_\_ STAINLESS STEEL PER ASTM-A-479, TYPE 304

CONTACT \_\_\_\_\_ BERYLLIUM COPPER PER ASTM-B-196/B, 196M-03, COPPER ALLOY No. UNS-C17300, TEMPER TD04.

INSULATORS \_\_\_\_\_ TEFLON PER ASTM-D-1710-02, TYPE 1, GRADE 1, CLASS B.

FLANGE O-RING \_\_\_\_\_ FLOUROSILICONE PER MIL-R-25988, TYPE 1, CLASS 1, GRADE 60/3.

## 6. FINISH

BODY, LOCKWASHER & HEX NUT \_\_\_\_\_ PASSIVATE PER AMS-2700, TYPE 2, CLASS 4.

CONTACT \_\_\_\_\_ GOLD PER ASTM-B-488, TYPE II, CODE C, CLASS 1.27  
(.000050 MIN. THK.) OVER NICKEL per SAE AMS-QQ-N-290  
(.000050 MIN. THK.) OVER COPPER per AMS-2418  
(.000010 MIN. THK.)

INSULATORS & O-RING \_\_\_\_\_ N/A