

# SPECIFICATION CONTROL DRAWING

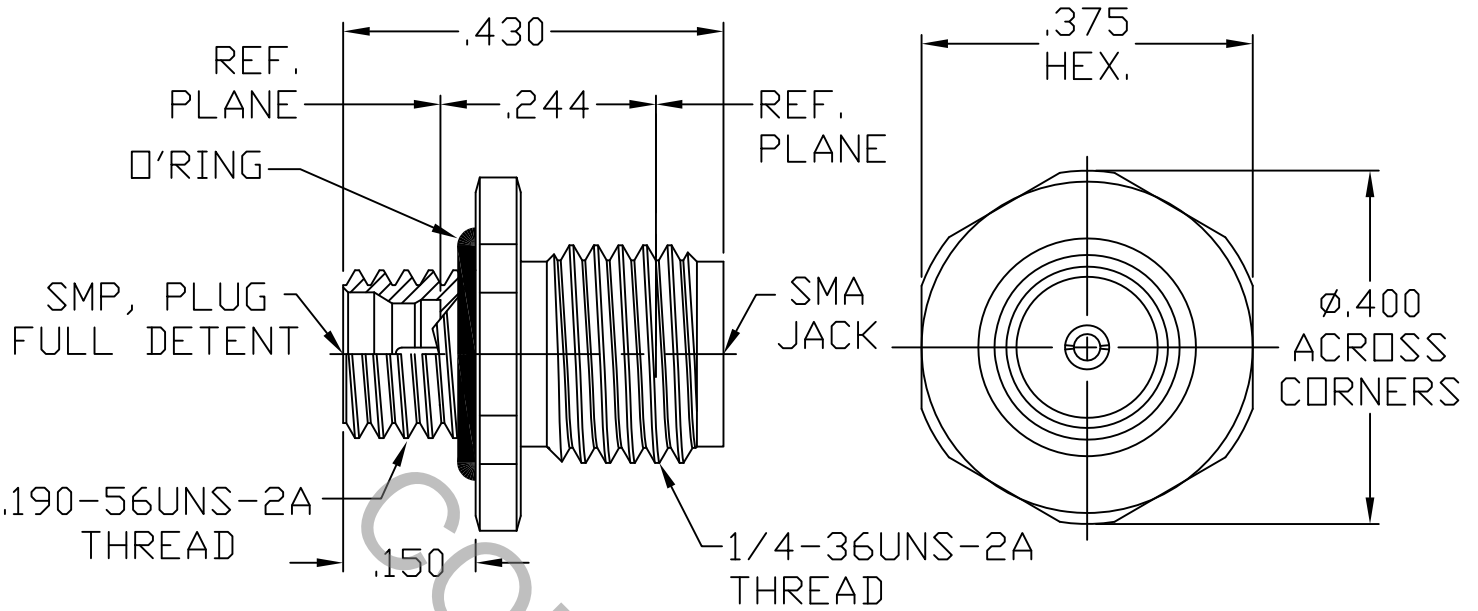

1. MATING INTERFACE DIMENSIONS PER MIL-STD-348A, Fig. 326.2 (SMP, MALE, FULL DETENT) AND MIL-STD-348A Fig 310.2 (SMA, JACK).
2. ELECTRICAL

FREQUENCY RANGE GHz	DC TO 26.5 GHz
VSWR (MAX) *	1.05 + .005 x FGHz
INSERTION LOSS (dB MAX) *	.04 dB x √FGHz
NOMINAL IMPEDANCE (OHMS)	50
VOLTAGE RATING (MAX. VRMS)	170
RF LEAKAGE (MIN. dB DOWN)	-100 dB - FGHz
TEMPERATURE RATING (DEGREES CENTIGRADE)	-65°c TO + 165°c
DIELECTRIC WITHSTANDING VOLTAGE (MAX. VRMS)	500
INSULATION RESISTANCE (MIN. MEGOHMS)	5,000
CONTACT RESISTANCE	
• CENTER CONTACT (MAX. MILLIOHMS)	6.0
• OUTER CONTACT (MAX. MILLIOHMS)	2.0

\* TERMINATED IN A 50 OHM LOAD

**RoHS**  
COMPLIANT

This Document contains proprietary and confidential information.

REV.	DCN NO.	DATE	APP.	DIMENSIONS ARE IN INCHES TOLERANCES			 HAVERHILL, MA 01835
AA	16-1075	1/21/16	TS	DECIMALS .X ± .030 .XX ± .010 .XXX ± .005	FRACTIONAL ± 1/64	ANGULAR X ° ± 1° 0' X ° X' ± 15'	
				DRAWN TS	DATE 1/21/16	<b>TITLE</b> SMP MALE, (FULL DETENT) TO SMA JACK, PANEL MOUNT ADAPTER	
				APPROVED DC	DATE 1/21/16		
				CODE IDENT. 2J899	SHEET 1 OF 2		<b>DWG. NO.</b> 1130-2199-3201

# SPECIFICATION CONTROL DRAWING

## 3. MECHANICAL

### CAPTIVATION-CENTER CONTACT

MAX AXIAL FORCE \_\_\_\_\_ 3.5 LBS.

MAX RADIAL TORQUE \_\_\_\_\_ N/A

### CONNECTOR ENGAGEMENT FORCE

● INSERTION (MAX. LBS.) \_\_\_\_\_ 15.0 (FULL DETENT)

● WITHDRAWAL (MIN. LBS.) \_\_\_\_\_ 5.0 (FULL DETENT)

CONNECTOR DURABILITY (MIN. CYCLES) \_\_\_\_\_ 100

RECOMMENDED MATING TORQUE \_\_\_\_\_ 7 - 10 IN. LBS. (SMA)

## 4. ENVIRONMENTAL

TEMPERATURE CYCLING \_\_\_\_\_ MIL-STD-202, METHOD 102, COND. C ( -65° c TO + 165° c )

SHOCK \_\_\_\_\_ MIL-STD-202, METHOD 213, COND. I (100 G's)

VIBRATION \_\_\_\_\_ MIL-STD-202, METHOD 204, COND. D (20 G's)

MOISTURE RESISTANCE \_\_\_\_\_ MIL-STD-202, METHOD 106, LESS STEP 7b

CORROSION \_\_\_\_\_ MIL-STD-202, METHOD 101, COND. B (48 HOURS)

BAROMETRIC PRESSURE (ALTITUDE) \_\_\_\_\_ MIL-STD-202, METHOD 105, COND. C ( 70,000 FT. ) ( 125 VRMS )

## 5. MATERIAL

CONNECTOR BODIES, LOCKNUT AND LOCKWASHER — STAINLESS STEEL PER ASTM A 479, TYPE 316L

CENTER CONTACT \_\_\_\_\_ BERYLLIUM COPPER PER ASTM B196/B, 196M-03, COPPER ALLOY No. UNS C17300, TEMPER TD04.

INSULATORS \_\_\_\_\_ TEFLON PER ASTM D 1710-02, TYPE 1, CLASS 1, GRADE B.

O'RING \_\_\_\_\_ ETHYLENE PROPYLENE PER ASTM D735-58/R810F

## 6. FINISH

CONNECTOR BODIES, LOCKNUT AND LOCKWASHER — PASSIVATE PER AMS 2700, TYPE 2, CLASS 4.

CENTER CONTACT \_\_\_\_\_ GOLD PER ASTM-B-488, TYPE I, CODE C, CLASS 1.25  
(.000050 MIN. THK.) OVER NICKEL PER SAE AMS QQ-N-290, CLASS 1  
(.000050 MIN. THK.) OVER COPPER PER AMS 2418 (.000010 MIN. THK.)

INSULATORS AND O'RING \_\_\_\_\_ N/A