

SPECIFICATION CONTROL DRAWING

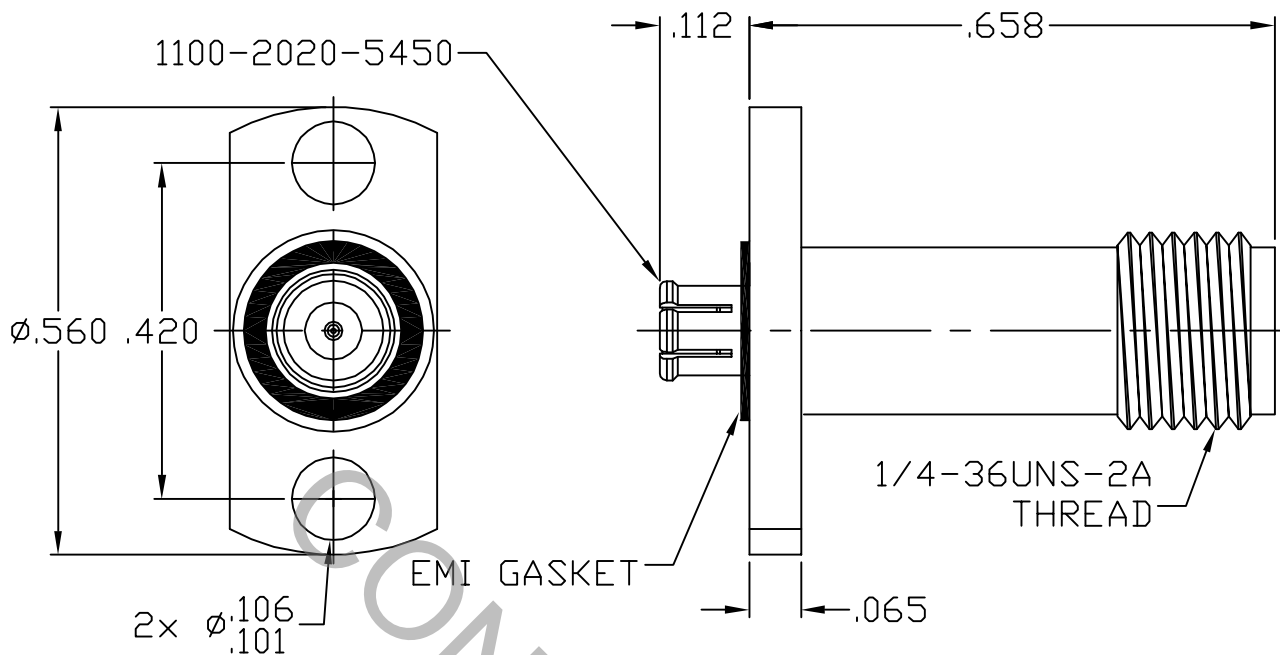

1. MATING INTERFACE DIMENSIONS Per MIL-STD-348
Fig. 326.2 (SMP MALE F.D.) AND Fig. 310.2 (SMA JACK).
SEE SCD 1100-2020-5450 FOR SMP FEMALE BULLET INFORMATION.
2. ELECTRICAL

FREQUENCY RANGE GHz	DC TO 26.5 GHz
VSWR (MAX.) *	1.05 + .010 x FGHz
INSERTION LOSS (dB MAX.) *	.04 dB x $\sqrt{\text{FGHz}}$
NOMINAL IMPEDANCE (OHMS)	50
VOLTAGE RATING (MAX. VRMS)	170
RF LEAKAGE (MIN. dB DOWN)	-85 dB - FGHz
TEMPERATURE RATING (DEGREES CENTIGRADE)	-65°c TO + 165°c
DIELECTRIC WITHSTANDING VOLTAGE (MAX. VRMS)	500
INSULATION RESISTANCE (MIN. MEGOHMS)	5,000
CONTACT RESISTANCE	
• CENTER CONTACT (MAX. MILLIOHMS)	3.0
• OUTER CONTACT (MAX. MILLIOHMS)	2.0

* TERMINATED IN A 50 OHM LOAD

REV.	DCN NO.	DATE	APP.	DIMENSIONS ARE IN INCHES TOLERANCES			HAVERHILL, MA 01835
AA	07-2015	10/16/07	DC	DECIMALS .X ± .030 .XX ± .010 .XXX ± .005	FRACTIONAL ± 1/64	ANGULAR X ° ± 1'0" X ° X' ± 15'	
				DRAWN TS	DATE 10/13/07	TITLE SMP, JACK TO SMA, JACK 2 HOLE FLANGE MOUNT ADAPTER	
				APPROVED DC	DATE 10/13/07		
				CODE IDENT. 2J899	SHEET 1 OF 2	DWG. NO.	1152-2099-6200

SPECIFICATION CONTROL DRAWING

3. MECHANICAL

CAPTIVATION-CENTER CONTACT

MAX AXIAL FORCE _____ 4.5 LBS.

MAX RADIAL TORQUE _____ N/A

CENTER CONTACT AXIAL FORCES

● INSERTION (MAX OUNCES) _____ SMA INTERFACE 32.0

● WITHDRAWAL (MIN. OUNCES) _____ SMA INTERFACE 2.0

CONNECTOR ENGAGEMENT (MAX. LBS.) _____ SMA 2.0, SMP 15.0

CONNECTOR DURABILITY (MIN. CYCLES) _____ 500

RECOMMENDED MATING TORQUE _____ SMA 7 - 10 IN. LBS.

4. ENVIRONMENTAL

TEMPERATURE CYCLING _____ MIL-STD-202, METHOD 102, COND. C (-65° c TO +165° c)

SHOCK _____ MIL-STD-202, METHOD 213, COND. I (100 G's)

VIBRATION _____ MIL-STD-202, METHOD 204, COND. D (20 G's)

MOISTURE RESISTANCE _____ MIL-STD-202, METHOD 106, LESS STEP 7b

CORROSION _____ MIL-STD-202, METHOD 101, COND. B (48 HOURS)

BAROMETRIC PRESSURE (ALTITUDE) _____ MIL-STD-202, METHOD 105, COND. C (70,000 FT.) (125 VRMS)

5. MATERIAL

BODY _____ STAINLESS STEEL PER ASTM-A-582, TYPE 303, COND. A

CONTACT _____ BERYLLIUM COPPER PER ASTM-B-196-90, COPPER ALLOY
No. UNS-C17300, TEMPER TD04.

EMI GASKET _____ SILVER PLATED ALUMINUM IN SILICONE.

INSULATOR _____ TEFLON PER ASTM-D-1710.

6. FINISH

BODY _____ PASSIVATE PER AMS QQ-P-35, TYPE 2.

CONTACT _____ GOLD PER ASTM-B-488, TYPE I, CODE C, CLASS 2.5
(.000100 MIN. THK.) OVER NICKEL per QQ-N-290
(.000050 MIN. THK.) OVER COPPER per MIL-C-14550
(.000010 MIN. THK.)

INSULATOR AND EMI GASKET _____ N/A