

# SPECIFICATION CONTROL DRAWING

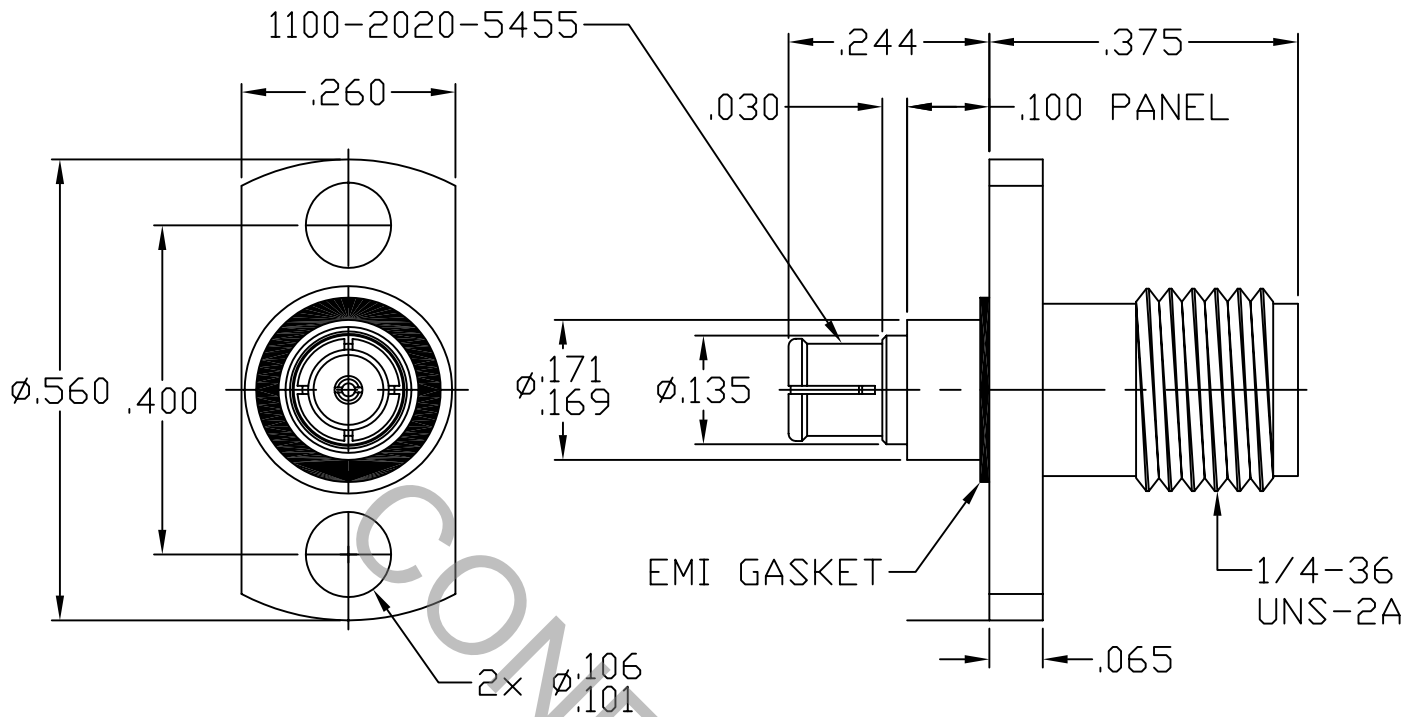

- MATING INTERFACE DIMENSIONS Per MIL-STD-348  
INT Fig. 326.2 (SMP MALE FD) AND Fig. 310.2 (SMA JACK).  
SEE SCD 1100-2020-5455 FOR SMP FEMALE BULLET INFORMATION.

## 2. ELECTRICAL

FREQUENCY RANGE GHz	_____	DC TO 26.5 GHz
VSWR (MAX.) *	_____	1.05 + .010 x FGHz
INSERTION LOSS (dB MAX.) *	_____	.04 dB x $\sqrt{\text{FGHz}}$
NOMINAL IMPEDANCE (OHMS)	_____	50
VOLTAGE RATING (MAX. VRMS)	_____	170
RF LEAKAGE (MIN. dB DOWN)	_____	-85 dB - FGHz
TEMPERATURE RATING (DEGREES CENTIGRADE)	_____	-65°c TO + 165°c
DIELECTRIC WITHSTANDING VOLTAGE (MAX. VRMS)	_____	500
INSULATION RESISTANCE (MIN. MEGOHMS)	_____	5,000
CONTACT RESISTANCE		
• CENTER CONTACT (MAX. MILLIOHMS)	_____	3.0
• OUTER CONTACT (MAX. MILLIOHMS)	_____	2.0

\* TERMINATED IN A 50 OHM LOAD

**RoHS**  
COMPLIANT

REV.	DCN NO.	DATE	APP.	DIMENSIONS ARE IN INCHES TOLERANCES				 INCORPORATED HAVERHILL, MA 01835	
AA	08-1391	4/9/08	TS	DECIMALS .X ± .030 .XX ± .010 .XXX ± .005	FRACTIONAL ± 1/64	ANGULAR X ° ± 1° 0' X ° X' ± 15'			
				DRAWN	TS	DATE	4/9/08	TITLE SMP JACK TO SMA JACK 2 HOLE FLANGE MOUNT ADAPTER	
				APPROVED	DC	DATE	4/9/08		
				CODE IDENT.			SHEET 1 OF 2	DWG. NO. 1152-2099-6203	
				2J899					

# SPECIFICATION CONTROL DRAWING

## 3. MECHANICAL

### CAPTIVATION-CENTER CONTACT

MAX AXIAL FORCE \_\_\_\_\_ 4.5 LBS.

MAX RADIAL TORQUE \_\_\_\_\_ N/A

### CENTER CONTACT AXIAL FORCES

● INSERTION (MAX OUNCES) \_\_\_\_\_ SMA INTERFACE 32.0

● WITHDRAWAL (MIN. OUNCES) \_\_\_\_\_ SMA INTERFACE 2.0

CONNECTOR ENGAGEMENT/DISENGAGEMENT (MAX LBS.) \_\_\_\_\_ SMA 2.0, SMP 15.0

CONNECTOR DURABILITY (MIN. CYCLES) \_\_\_\_\_ 500

RECOMMENDED MATING TORQUE \_\_\_\_\_ SMA 7 - 10 IN. LBS.

## 4. ENVIRONMENTAL

TEMPERATURE CYCLING \_\_\_\_\_ MIL-STD-202, METHOD 102, COND. C ( -65° c TO + 165° c )

SHOCK \_\_\_\_\_ MIL-STD-202, METHOD 213, COND. I (100 G's)

VIBRATION \_\_\_\_\_ MIL-STD-202, METHOD 204, COND. D (20 G's)

MOISTURE RESISTANCE \_\_\_\_\_ MIL-STD-202, METHOD 106, LESS STEP 7b

CORROSION \_\_\_\_\_ MIL-STD-202, METHOD 101, COND. B (48 HOURS)

BAROMETRIC PRESSURE (ALTITUDE) \_\_\_\_\_ MIL-STD-202, METHOD 105, COND. C ( 70,000 FT. ) ( 125 VRMS )

## 5. MATERIAL

BODY \_\_\_\_\_ STAINLESS STEEL PER ASTM-A-582, TYPE 303, COND. A

CONTACT \_\_\_\_\_ BERYLLIUM COPPER PER ASTM-B-196/B, 196M-03, COPPER ALLOY No. UNS-C17300, TEMPER TD04.

INSULATOR \_\_\_\_\_ TEFLON PER ASTM-D-1710-02, TYPE 1, GRADE 1, CLASS B.

EMI GASKET \_\_\_\_\_ SILVER PLATED ALUMINUM IN SILICONE

## 6. FINISH

BODY \_\_\_\_\_ PASSIVATE PER AMS QQ-P-35, TYPE 2.

CONTACT \_\_\_\_\_ GOLD PER ASTM-B-488, TYPE I, CODE C, CLASS 2.5  
(.000100 MIN. THK.) OVER NICKEL per QQ-N-290  
(.000050 MIN. THK.) OVER COPPER per MIL-C-14550  
(.000010 MIN. THK.)

INSULATOR & EMI GASKET \_\_\_\_\_ N/A