

SPECIFICATION CONTROL DRAWING

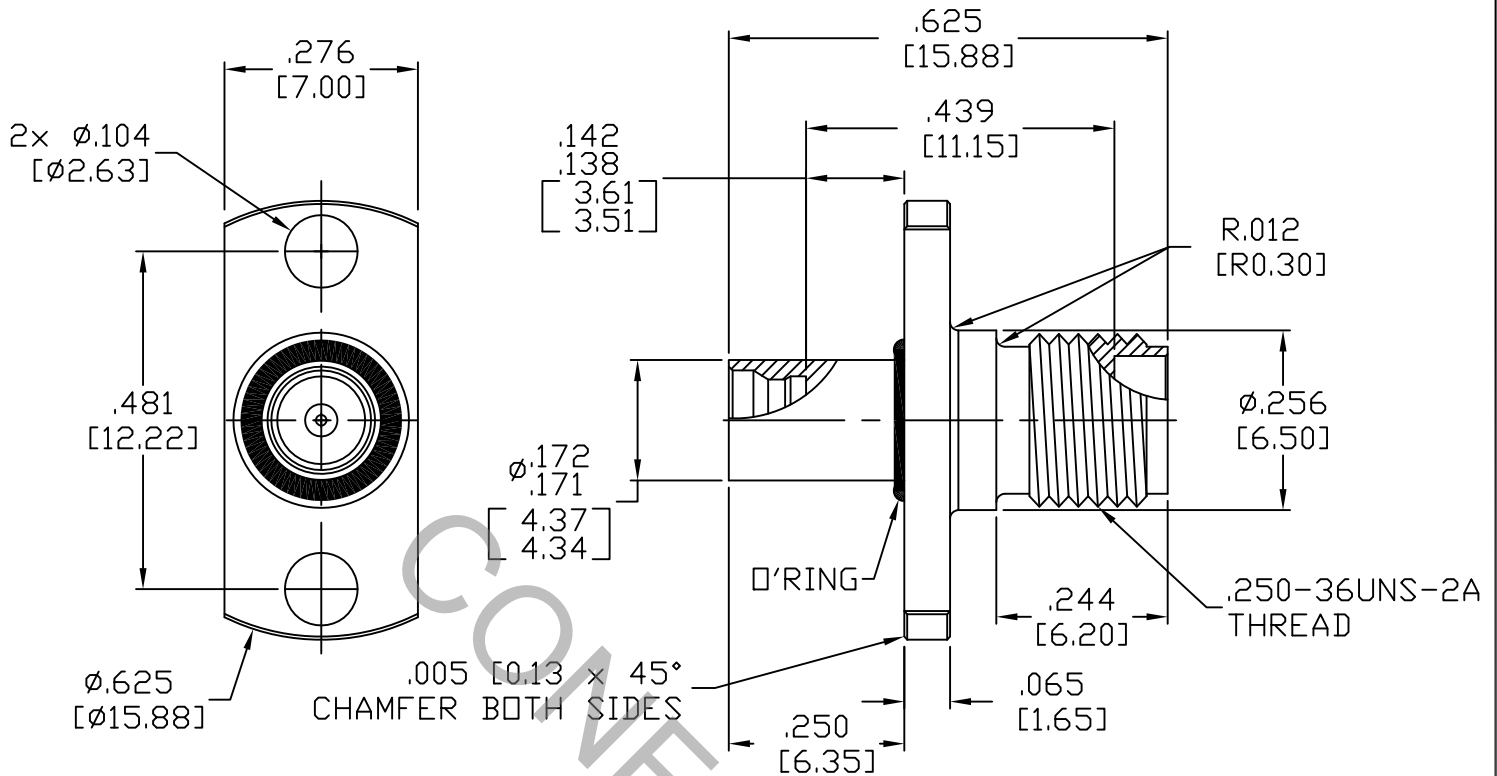

1. MATING INTERFACE DIMENSIONS PER MIL-STD-348A, (Fig. 326.2), (SMP, PLUG, FULL DETENT)
MIL-STD-348A, (Fig. 310.2), (SMA, JACK)

2. ELECTRICAL

FREQUENCY RANGE GHz	_____	DC TO 18.0 GHz.
VSWR (MAX.) *	_____	1.05 + .010 x FGHz.
INSERTION LOSS (dB MAX.)	_____	.040 dB x √FGHz
NOMINAL IMPEDANCE (OHMS)	_____	50
VOLTAGE RATING (MAX. VRMS)	_____	190
RF LEAKAGE (MIN. dB DOWN)	_____	-85 dB - FGHz.
TEMPERATURE RATING (DEGREES CENTIGRADE)	_____	-65°C TO + 165°C
DIELECTRIC WITHSTANDING VOLTAGE (MAX. VRMS)	_____	500
INSULATION RESISTANCE (MIN. MEGOHMS)	_____	5,000
CONTACT RESISTANCE		
• CENTER CONTACT (MAX. MILLIOHMS)	_____	3.0
• OUTER CONTACT (MAX. MILLIOHMS)	_____	2.0

* TERMINATED IN A 50 OHM LOAD

RoHS
COMPLIANT

This Document contains proprietary and confidential information.

REV.	DCN NO.	DATE	APP.	DIMENSIONS ARE IN INCHES TOLERANCES	
AA	18-1130	1/23/18	TS	DECIMALS .X ± .030 .XX ± .010 .XXX ± .005	HAVERHILL, MA 01835
				FRACTIONAL ± 1/64	
				ANGULAR X° ± 1°0' X°X' ± 15'	
				DRAWN TS	TITLE SMP, PLUG (FD) TO SMA, JACK 2 HOLE FLANGE ADAPTER
				DATE 1/23/18	
				APPROVED DC	
				DATE 1/23/18	
				CODE IDENT. 2J899	DWG. NO. 1152-2199-6213
				SHEET 1 OF 2	

SPECIFICATION CONTROL DRAWING

3. MECHANICAL

CAPTIVATION-CENTER CONTACT
MAX.AXIAL FORCE _____ 4.5 LBS.
MAX. RADIAL TORQUE _____ N/A
CENTER CONTACT AXIAL FORCES
● INSERTION (MAX. OUNCES) _____ 32.0
● WITHDRAWAL (MIN. OUNCES) _____ 2.0
CONNECTOR ENGAGEMENT/DISENGAGEMENT (MAX. IN. LBS.) _____ 2.0
CONNECTOR DURABILITY (MIN. CYCLES) _____ 100
RECOMMENDED MATING TORQUE _____ 7 - 10 IN. LBS.

4. ENVIRONMENTAL

TEMPERATURE CYCLING _____ MIL-STD-202, METHOD 102, COND. C (-65°C TO + 165°C)
SHOCK _____ MIL-STD-202, METHOD 213, COND. I (100 G's)
VIBRATION _____ MIL-STD-202, METHOD 204, COND. D (20 G's)
MOISTURE RESISTANCE _____ MIL-STD-202, METHOD 106, LESS STEP 7b
CORROSION _____ MIL-STD-202, METHOD 101, COND. B (48 HOURS)
BAROMETRIC PRESSURE (ALTITUDE) _____ MIL-STD-202, METHOD 105, COND. C (70,000 FT.) (190 VRMS)

5. MATERIAL

BODY _____ STAINLESS STEEL PER ASTM A 582, TYPE 303, COND. A.
CONTACT _____ BERYLLIUM COPPER PER ASTM B196/B, 196M-03, COPPER
ALLOY No. UNS-C17300, TEMPER TD04.
INSULATOR _____ TEFLON PER ASTM-D-1710-02, TYPE 1, GRADE 1, CLASS B.
O'RING _____ SILICONE RUBBER PER A-A-59588, CLASS 1.

6. FINISH

BODY _____ PASSIVATE PER AMS-2700, TYPE 2, CLASS 4
CONTACT _____ GOLD PER ASTM-B-488, TYPE I, CODE C, CLASS 1.25
(.000050 MIN. THK.) OVER NICKEL PER SAE-AMS-QQ-N-290
CLASS 1 (.000050 MIN. THK.) OVER COPPER PER AMS-2418
(.000010 MIN. THK.)
INSULATOR AND O'RING _____ N/A