

# SPECIFICATION CONTROL DRAWING

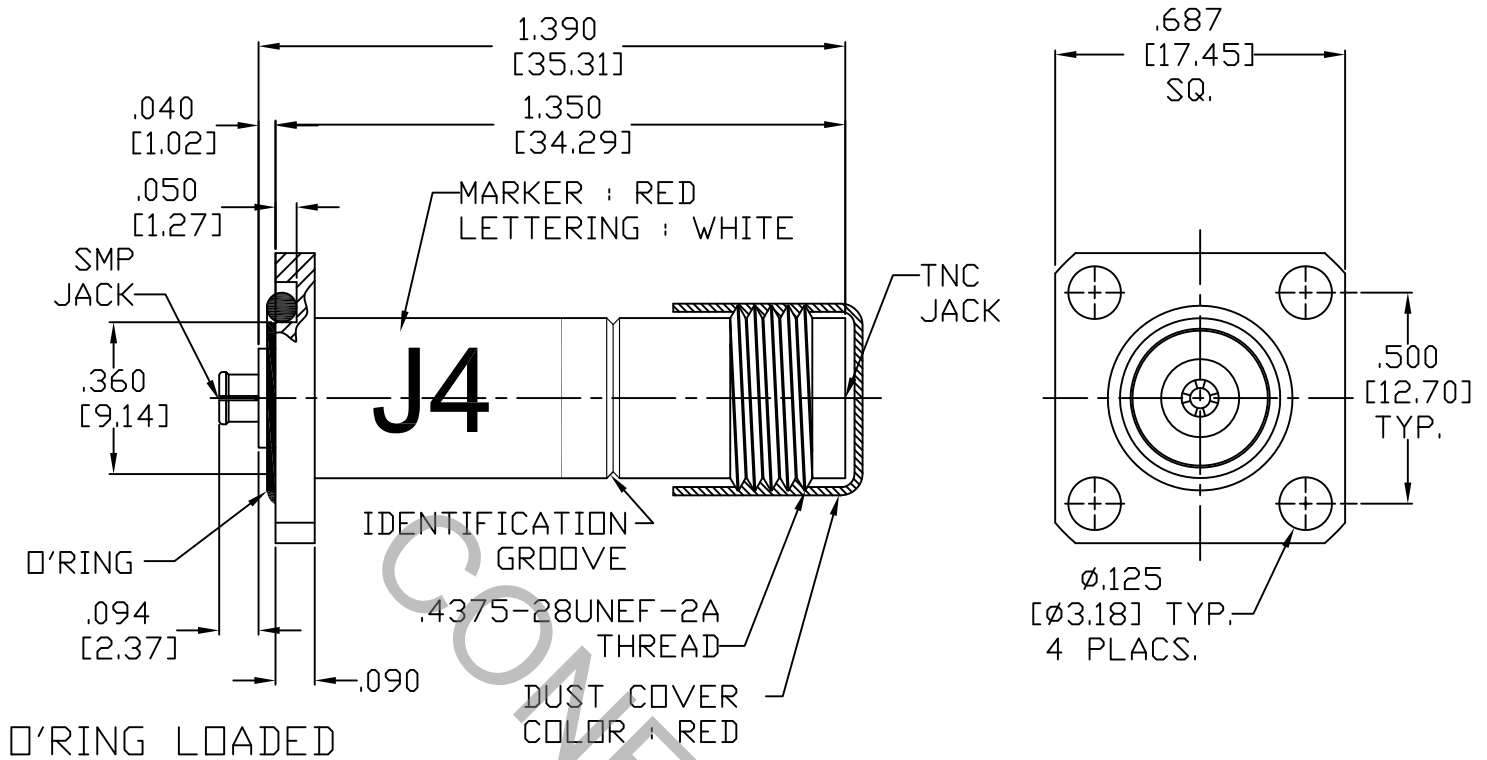

1. MATING INTERFACE DIMENSIONS Per MIL-STD-348 Fig. 326.1 (SMP, JACK) AND MIL-STD-348A, Fig. 313.2, (TNC, JACK)
2. ELECTRICAL

FREQUENCY RANGE GHz	DC TO 1.1 GHz
VSWR (MAX) *	1.08 + .015 x FGHz
INSERTION LOSS (dB MAX) *	.10 dB x √FGHz
NOMINAL IMPEDANCE (OHMS)	50
VOLTAGE RATING (MAX. VRMS)	500
RF LEAKAGE (MIN. dB DOWN)	-100 dB - FGHz
TEMPERATURE RATING (DEGREES CENTIGRADE)	-65°c TO + 165°c
DIELECTRIC WITHSTANDING VOLTAGE (MAX. VRMS)	500
INSULATION RESISTANCE (MIN. MEGOHMS)	5,000
CONTACT RESISTANCE	
• CENTER CONTACT (MAX. MILLIOHMS)	6.0
• OUTER CONTACT (MAX. MILLIOHMS)	2.0
* TERMINATED IN A 50 OHM LOAD	

**RoHS**

This Document contains proprietary and confidential information. COMPLIANT

REV.	DCN NO.	DATE	APP.	DIMENSIONS ARE IN INCHES TOLERANCES				 HAVERHILL, MA 01835	
AA	14-1937	8/4/14	TS	DECIMALS .X ± .030 .XX ± .010 .XXX ± .005	FRACTIONAL ± 1/64	ANGULAR X ° ± 1° 0' X ° X' ± 15'	TITLE SMP, JACK TO TNC, JACK, 4 HOLE FLANGE MOUNT ADAPTER		
AB	14-2337	10/21/14	TS						
BA	14-2427	11/11/14	DC	DRAWN	TS	DATE			
				APPROVED	DC	DATE	8/4/14		
				CODE IDENT.			SHEET 1 OF 2	DWG. NO.	1154-2085-2745
				2J899					

# SPECIFICATION CONTROL DRAWING

## 3. MECHANICAL

### CAPTIVATION-CENTER CONTACT

MAX AXIAL FORCE \_\_\_\_\_ 6.0 LBS.

MAX RADIAL TORQUE \_\_\_\_\_ N/A

### CENTER CONTACT AXIAL FORCES

● INSERTION (MAX. OUNCES) \_\_\_\_\_ INTERFACE 32.0

● WITHDRAWAL (MIN. OUNCES) \_\_\_\_\_ INTERFACE 2.0

CONNECTOR ENGAGEMENT/DISENGAGEMENT (MAX. LBS.) \_\_\_\_\_ 2.0

CONNECTOR DURABILITY (MIN. CYCLES) \_\_\_\_\_ 500

RECOMMENDED MATING TORQUE \_\_\_\_\_ 15 - 20 IN. LBS.

## 4. ENVIRONMENTAL

TEMPERATURE CYCLING \_\_\_\_\_ MIL-STD-202, METHOD 107, COND. C ( -65° c TO + 165° c )

SHOCK \_\_\_\_\_ MIL-STD-202, METHOD 213, COND. I (100 G's)

VIBRATION \_\_\_\_\_ MIL-STD-202, METHOD 204, COND. D (20 G's)

MOISTURE RESISTANCE \_\_\_\_\_ MIL-STD-202, METHOD 106, LESS STEP 7b

CORROSION \_\_\_\_\_ MIL-STD-202, METHOD 101, COND. B (48 HOURS)

BAROMETRIC PRESSURE (ALTITUDE) \_\_\_\_\_ MIL-STD-202, METHOD 105, COND. C ( 70,000 FT. ) ( 190 VRMS )

INGRESS PROTECTION \_\_\_\_\_ IP68

## 5. MATERIAL

TNC BODY \_\_\_\_\_ BRASS PER ASTM B 16, TEMPER H02, ALLOY C36000.

SMP BODY AND CONTACT \_\_\_\_\_ BERYLLIUM COPPER PER ASTM-B-196/B, 196M-03, COPPER  
ALLOY No. UNS-C17300, TEMPER TD04.

INSULATOR \_\_\_\_\_ TEFLON PER ASTM D-1710-02, TYPE 1, GRADE 1, CLASS B.

DUST COVER \_\_\_\_\_ VINYL (COLOR RED)

O-RING'S \_\_\_\_\_ SILICONE RUBBER PER ZZ-R-765E, CLASS 1.

## 6. FINISH

TNC BODY \_\_\_\_\_ NICKEL PER QQ-N-290, CLASS 1.

SMP BODY \_\_\_\_\_ GOLD PER ASTM-B-488, TYPE I, CODE C, CLASS 1.25  
(.000050 MIN. THK.) OVER NICKEL PER SAE AMS QQ-N-290, CLASS 1  
(.000150 MIN. THK.) OVER COPPER PER AMS 2418 (.000010 MIN.THK.)

CONTACT \_\_\_\_\_ GOLD PER ASTM-B-488, TYPE I, CODE C, CLASS 1.27  
(.000050 MIN. THK.) OVER NICKEL PER SAE AMS QQ-N-290, CLASS 1  
(.000050 MIN. THK.) OVER COPPER PER AMS 2418 (.000010 MIN. THK.)

INSULATOR, DUST COVER AND O-RING'S \_\_\_\_\_ N/A