

SPECIFICATION CONTROL DRAWING

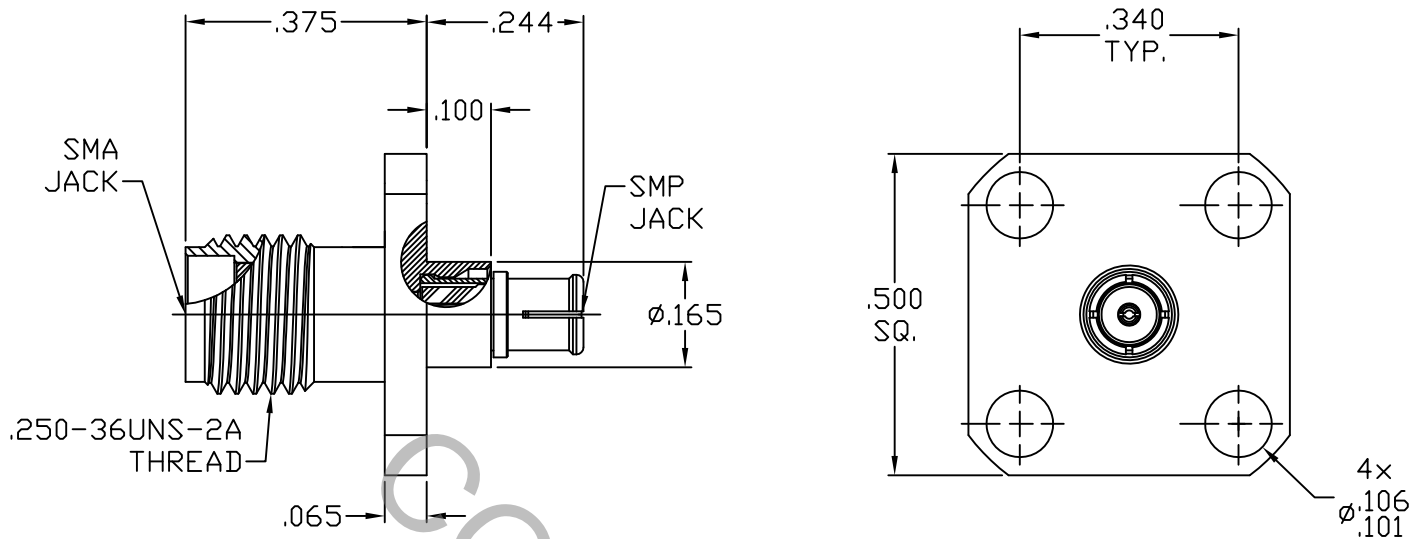

1. MATING INTERFACE DIMENSIONS Per MIL-STD-348 Fig. 326.2 (SMP MALE) FULL DETENT, Fig. 326.1 (SMP FEMALE) AND Fig. 310.2 (SMA JACK).

2. ELECTRICAL

FREQUENCY RANGE GHz	_____	DC TO 26.5 GHz
VSWR (MAX) *	_____	1.05 + .010 x FGHz
INSERTION LOSS (dB MAX) *	_____	.10 dB x $\sqrt{\text{FGHz}}$
NOMINAL IMPEDANCE (OHMS)	_____	50
VOLTAGE RATING (MAX. VRMS)	_____	250
RF LEAKAGE (MIN. dB DOWN)	_____	-65 dB - FGHz
TEMPERATURE RATING (DEGREES CENTIGRADE)	_____	-65°C TO + 165°C
DIELECTRIC WITHSTANDING VOLTAGE (MAX. VRMS)	_____	500
INSULATION RESISTANCE (MIN. MEGOHMS)	_____	5,000
CONTACT RESISTANCE		
• CENTER CONTACT (MAX. MILLIOHMS)	_____	3.0
• OUTER CONTACT (MAX. MILLIOHMS)	_____	2.0

* TERMINATED IN A 50 OHM LOAD

RoHS
COMPLIANT

REV.	DCN NO.	DATE	APP.	DIMENSIONS ARE IN INCHES TOLERANCES			 HAVERHILL, MA 01835
				DECIMALS	FRACTIONAL	ANGULAR	
AA	09-1751	9/30/09	TS	.X ± .030		X ° ± 1° 0'	
AB	12-1112	2/2/12	TS	.XX ± .010	± 1/64	X ° X' ± 15'	
				.XXX ± .005			
				DRAWN TS	DATE 9/30/09	TITLE SMP FEMALE TO SMA JACK, 4 HOLE FLANGE ADAPTER	
				APPROVED DC	DATE 9/30/09		
				CODE IDENT. 2J899	SHEET 1 OF 2	DWG. NO. 1154-2099-6250	

SPECIFICATION CONTROL DRAWING

3. MECHANICAL

CAPTIVATION-CENTER CONTACT

MAX AXIAL FORCE _____ 4.5 LBS.

MAX RADIAL TORQUE _____ N/A

CENTER CONTACT AXIAL FORCES

● INSERTION (MAX OUNCES) _____ INTERFACES 32.0

● WITHDRAWAL (MIN. OUNCES) _____ SMP INTERFACE 1.0, SMA 2.0

CONNECTOR ENGAGEMENT/DISENGAGEMENT (MAX LBS.) _____ 2.0 SMA

CONNECTOR DURABILITY (MIN. CYCLES) _____ SMA 500, SMP 100

RECOMMENDED MATING TORQUE _____ SMA 7 - 10 IN. LBS.

4. ENVIRONMENTAL

THERMAL SHOCK _____ MIL-STD-202, METHOD 107, COND. B (-65° c TO +165° c)

SHOCK _____ MIL-STD-202, METHOD 213, COND. I (100 G's)

VIBRATION _____ MIL-STD-202, METHOD 204, COND. D (20 G's)

MOISTURE RESISTANCE _____ MIL-STD-202, METHOD 106, LESS STEP 7b

CORROSION _____ MIL-STD-202, METHOD 101, COND. B (48 HOURS)

BAROMETRIC PRESSURE (ALTITUDE) _____ MIL-STD-202, METHOD 105, COND. C (70,000 FT.) (190 VRMS)

5. MATERIAL

SMA BODY _____ STAINLESS STEEL PER ASTM-A-582, TYPE 303, COND. A

SMP BODY & CONTACTS _____ BERYLLIUM COPPER PER ASTM-B-196/B, 196M-03, COPPER ALLOY No. UNS-C17300, TEMPER TD04.

INSULATORS _____ TEFLON PER ASTM-D-1710-02, TYPE 1, GRADE 1, CLASS B.

6. FINISH

SMA BODY _____ PASSIVATE PER AMS-2700, TYPE 2, CLASS 4.

SMP BODY _____ GOLD PER ASTM-B-488, TYPE I, CODE C, CLASS 1.27 (.000050 - .000100 THK.) OVER NICKEL PER SAE-AMS-QQ-N-290 CLASS 1 (.000100 MIN. THK.) OVER COPPER PER AMS-2418 (.000040 MIN. THK.).

CONTACTS _____ GOLD PER ASTM-B-488, TYPE I, CODE C, CLASS 1.27 (.000050 MIN. THK.) OVER NICKEL PER SAE-AMS-QQ-N-290 CLASS 1 (.000050 MIN. THK.) OVER COPPER PER AMS-2418 (.000010 MIN. THK.)

INSULATORS _____ N/A