

SPECIFICATION CONTROL DRAWING

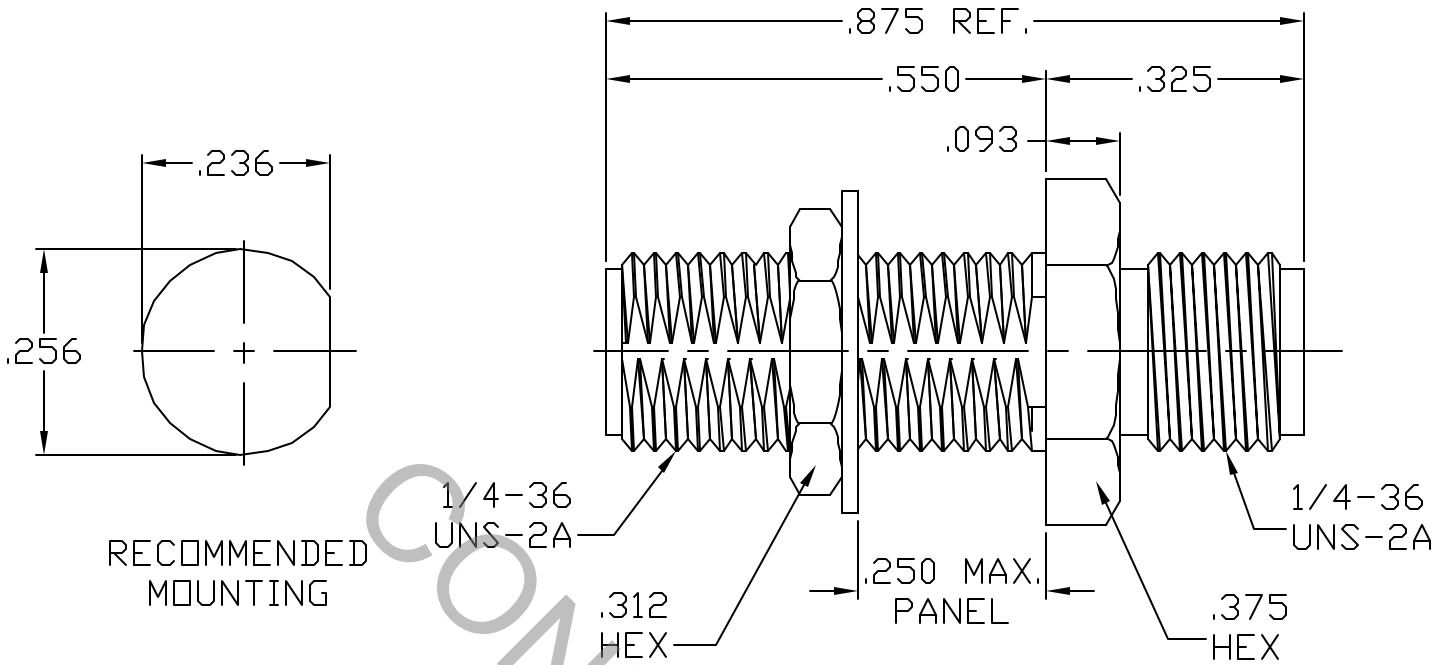

1. MATING INTERFACE DIMENSIONS MIL-STD-348 Fig. 310.2 (SMA JACK).

2. ELECTRICAL

| | |
|--|-------------------------------|
| FREQUENCY RANGE GHz | DC TO 26.5 GHz |
| VSWR (MAX.) * | 1.05 + .006 x FGHz |
| INSERTION LOSS (dB MAX.) * | .03 dB x $\sqrt{\text{FGHz}}$ |
| NOMINAL IMPEDANCE (OHMS) | 50 |
| VOLTAGE RATING (MAX VRMS) | 250 |
| RF LEAKAGE (MIN. dB DOWN) | 100 dB - FGHz |
| TEMPERATURE RATING (DEGREES CENTIGRADE) | -65°C TO + 165°C |
| DIELECTRIC WITHSTANDING VOLTAGE (MAX VRMS) | 750 |
| INSULATION RESISTANCE (MIN. MEGOHMS) | 10,000 |
| CONTACT RESISTANCE | |
| • CENTER CONTACT (MAX. MILLIOHMS) | 6.0 |
| • OUTER CONTACT (MAX. MILLIOHMS) | 2.0 |

* TERMINATED IN A 50 OHM LOAD

| REV. | DCN NO. | DATE | APP. | DIMENSIONS ARE IN INCHES TOLERANCES | | | HAVERHILL, MA 01835 |
|------|---------|------|------|--|--------------|-------------------------|--|
| - | 247 | 1/87 | CM | DECIMALS | FRACTIONAL | ANGULAR | |
| | | | | .X ± .030 .XX ± .010 .XXX ± .005 | ±/64 | X° ± 15' X' X' ± 15' | |
| | | | | DRAWN CDM | DATE | 1/87 | TITLE SMA, JACK TO SMA, JACK BULKHEAD MOUNT ADAPTER |
| | | | | APPROVED TS | DATE | 1/87 | |
| | | | | CODE IDENT. | SHEET 1 OF 2 | | DWG. NO. |
| | | | | 2J899 | | | 1180-9999-6287 |

SPECIFICATION CONTROL DRAWING

3. MECHANICAL

CAPTIVATION-CENTER CONTACT
MAX AXIAL FORCE _____ 8.0 LBS.
MAX RADIAL TORQUE _____ N/A
CENTER CONTACT AXIAL FORCES
● INSERTION (MAX. OUNCES) _____ 48.0
● WITHDRAWAL (MIN. OUNCES) _____ 2.0
CONNECTOR ENGAGEMENT/DISENGAGEMENT (MAX. IN. LBS.) — 2.0
CONNECTOR DURABILITY (MIN. CYCLES) _____ 500
RECOMMENDED MATING TORQUE _____ 7 - 10 IN. LBS.

4. ENVIRONMENTAL

TEMPERATURE CYCLING _____ MIL-STD-202, METHOD 102, COND. C (-85° c TO +200° c)
SHOCK _____ MIL-STD-202, METHOD 213, COND. I (100 G's)
VIBRATION _____ MIL-STD-202, METHOD 204, COND. D (20 G's)
MOISTURE RESISTANCE _____ MIL-STD-202, METHOD 106, LESS STEP 7b
CORROSION _____ MIL-STD-202, METHOD 101, COND. B (48 HOURS)
BAROMETRIC PRESSURE (ALTITUDE) — MIL-STD-202, METHOD 105, COND. C (70,000 FT.) (190 VRMS)

5. MATERIAL

BODY, LOCKNUT AND LOCKWASHER _____ STAINLESS STEEL PER AMS 5640, TYPE 303, COND. A
CONTACT _____ BERYLLIUM COPPER PER ASTM B198-90, COPPER ALLOY
No. UNS-C17300, TEMPER TD04.
INSULATOR _____ TEFLON PER ASTM D 4694-91.

6. FINISH

BODY, LOCKNUT AND LOCKWASHER _____ PASSIVATE PER AMS QQ-P-35, TYPE 2
CONTACT _____ GOLD PER ASTM B 488, TYPE II, CODE C, CLASS 2.5
(.000100 MIN. THK.) OVER NICKEL per QQ-N-290
(.000050 MIN. THK.) OVER COPPER per MIL-C-14550
(.000010 MIN. THK.)
INSULATOR _____ N/A