

SPECIFICATION CONTROL DRAWING

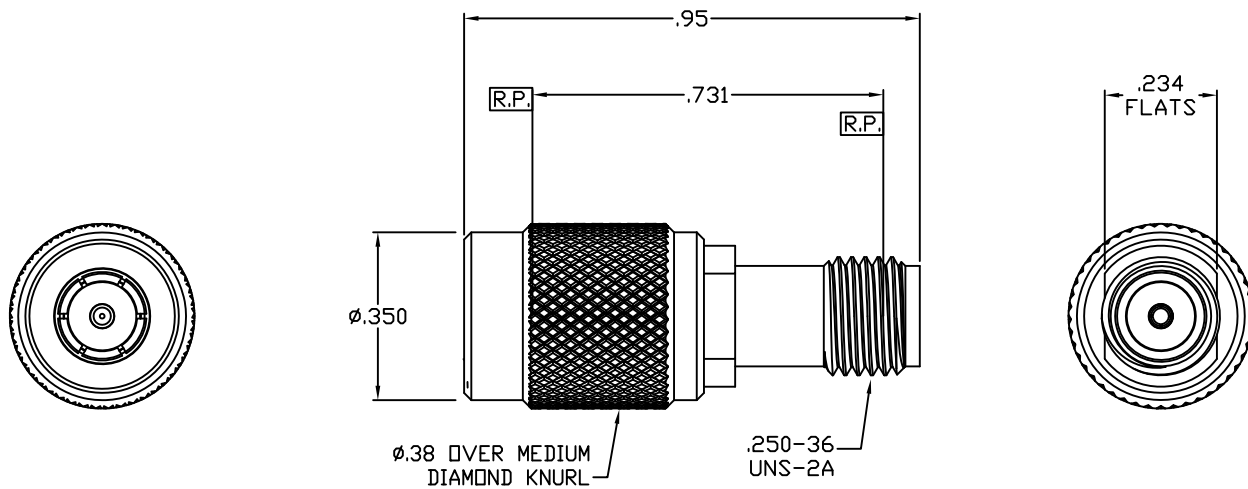

1. MATING INTERFACE DIMENSIONS Per MIL-STD-348 Fig. 310.1 (SMA PLUG) MODIFIED AND Fig. 310.2 (SMA JACK).

2. ELECTRICAL

FREQUENCY RANGE GHz	_____	DC TO 18.0 GHz
VSWR (MAX) *	_____	1.10 + .010 x FGHZ
INSERTION LOSS (dB MAX) *	_____	.07 dB x $\sqrt{\text{FGHZ}}$
NOMINAL IMPEDANCE (OHMS)	_____	50
VOLTAGE RATING (MAX. VRMS)	_____	333
RF LEAKAGE (MIN. dB DOWN)	_____	-65 dB - FGHZ
TEMPERATURE RATING (DEGREES CENTIGRADE)	_____	-65°c TO + 165°c
DIELECTRIC WITHSTANDING VOLTAGE (MAX. VRMS)	_____	1,000
INSULATION RESISTANCE (MIN. MEGOHMS)	_____	5,000
CONTACT RESISTANCE		
• CENTER CONTACT (MAX. MILLIOHMS)	_____	6.0
• OUTER CONTACT (MAX. MILLIOHMS)	_____	2.0

* TERMINATED IN A 50 OHM LOAD

RoHS

This Document contains proprietary and confidential information. **COMPLIANT**

REV.	DCN NO.	DATE	APP.	DIMENSIONS ARE IN INCHES TOLERANCES			 Haverhill, MA 01835
AA	15-1955	7/8/15	TS	DECIMALS	FRACTIONAL	ANGULAR	
				.X ± .030 .XX ± .010 .XXX ± .005	± 1/64	X ° ± 1'0" X ° X' ± 15'	TITLE SMA JACK TO PUSH ON SMA PLUG NON-LOCKING ADAPTER DWG. NO. 1190-9899-5702
				DRAWN TS	DATE	7/8/15	
				APPROVED DC	DATE	7/8/15	
				CODE IDENT. 2J899	SHEET 1 OF 2		

SPECIFICATION CONTROL DRAWING

3. MECHANICAL

CAPTIVATION-CENTER CONTACT

MAX AXIAL FORCE _____ 6.0 LBS.

MAX RADIAL TORQUE _____ N/A

CENTER CONTACT AXIAL FORCES

● INSERTION (MAX. OUNCES) _____ INTERFACE 32.0

● WITHDRAWAL (MIN. OUNCES) _____ INTERFACE 2.0

CONNECTOR ENGAGEMENT/DISENGAGEMENT (MAX. LBS.) _____ 2.0

CONNECTOR DURABILITY (MIN. CYCLES) _____ 500

RECOMMENDED MATING TORQUE _____ 7 - 10 IN. LBS.

4. ENVIRONMENTAL

TEMPERATURE CYCLING _____ MIL-STD-202, METHOD 102, COND. C (-65° c TO + 165° c)

SHOCK _____ MIL-STD-202, METHOD 213, COND. I (100 G's)

VIBRATION _____ MIL-STD-202, METHOD 204, COND. D (20 G's)

MOISTURE RESISTANCE _____ MIL-STD-202, METHOD 106, LESS STEP 7b

CORROSION _____ MIL-STD-202, METHOD 101, COND. B (48 HOURS)

BAROMETRIC PRESSURE (ALTITUDE) _____ MIL-STD-202, METHOD 105, COND. C (70,000 FT.) (250 VRMS)

5. MATERIAL

SHROUD _____ STAINLESS STEEL PER ASTM-A-582, TYPE 303, COND. A

BODY, CONTACT & SPRING FINGERS _____ BERYLLIUM COPPER PER ASTM-B-196/B, 196M-03 COPPER
ALLOY No. UNS-C17300, TEMPER TD04.

INSULATORS _____ TEFLON PER ASTM-D-1710-02, TYPE 1, GRADE 1, CLASS B.

6. FINISH

SHROUD _____ PASSIVATE PER AMS 2700, TYPE 2, CLASS 4.

BODY & SPRING FINGERS _____ NICKEL PER SAE AMS QQ-N-290, CLASS 1
(.000200 MIN. THK.) OVER COPPER PER AMS 2418 (.000010 MIN. THK.)

CONTACT _____ GOLD PER ASTM-B-488, TYPE I, CODE C, CLASS 1.27
(.000050 MIN. THK.) OVER NICKEL PER SAE AMS QQ-N-290, CLASS 1
(.000050 MIN. THK.) OVER COPPER PER AMS 2418 (.000010 MIN. THK.)

INSULATORS _____ N/A