

SPECIFICATION CONTROL DRAWING

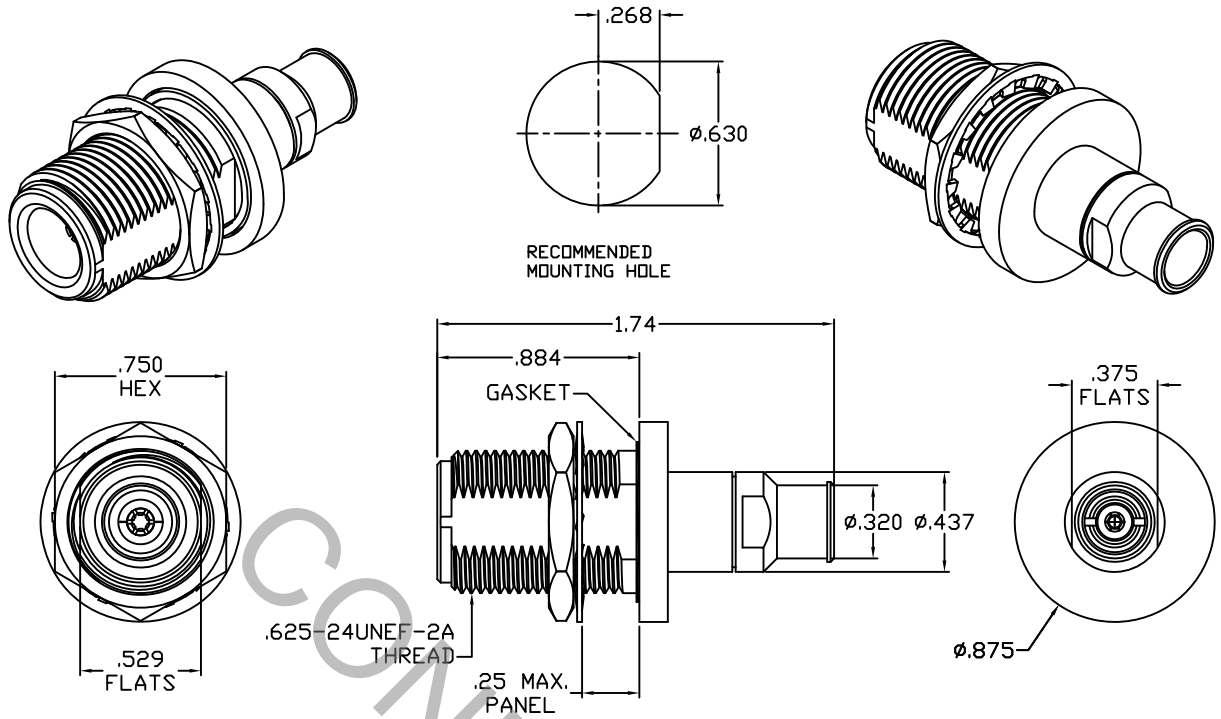

1. MATING INTERFACE DIMENSIONS Per MIL-STD-348 Fig. 304.2 (N JACK).

2. ELECTRICAL

FREQUENCY RANGE GHz	_____	DC TO 18.0 GHz
VSWR (MAX) *	_____	1.07 + .007 x FGHz
INSERTION LOSS (dB MAX) *	_____	.05 dB x √FGHz
NOMINAL IMPEDANCE (OHMS)	_____	50
VOLTAGE RATING (MAX. VRMS)	_____	500
RF LEAKAGE (MIN. dB DOWN)	_____	-100 dB - FGHz
TEMPERATURE RATING (DEGREES CENTIGRADE)	_____	-65°C TO + 165°C
DIELECTRIC WITHSTANDING VOLTAGE (MAX. VRMS)	_____	1,500
INSULATION RESISTANCE (MIN. MEGOHMS)	_____	5,000
CONTACT RESISTANCE		
• CENTER CONTACT (MAX. MILLIOHMS)	_____	6.0
• OUTER CONTACT (MAX. MILLIOHMS)	_____	2.0

* TERMINATED IN A 50 OHM LOAD

RoHS
COMPLIANT

REV.	DCN NO.	DATE	APP.	DIMENSIONS ARE IN INCHES TOLERANCES			CABLE INCORPORATED HAVERHILL, MA 01835	
AA	13-1668	5/6/13	DC	DECIMALS	FRACTIONAL	ANGULAR		
				.X ± .030		X ° ± 1° 0'	TITLE N JACK, BULKHEAD, SOLDER CLAMP, PLUG-IN CONTACT, DF126W	
				.XX ± .010	± 1/64	X ° X' ± 15'		
				.XXX ± .005				
				DRAWN RMS	DATE	5/6/13		
				APPROVED DC	DATE	5/6/13		
				CODE IDENT.	SHEET 1 OF 2		DWG. NO. 7510-126W-6240	
				6DZL5				

SPECIFICATION CONTROL DRAWING

3. MECHANICAL

CAPTIVATION-CENTER CONTACT

MAX AXIAL FORCE _____ 6.0 LBS.

MAX RADIAL TORQUE _____ N/A

CENTER CONTACT AXIAL FORCES

● INSERTION (MAX. OUNCES) _____ INTERFACE 32.0

● WITHDRAWAL (MIN. OUNCES) _____ INTERFACE 2.0

CONNECTOR ENGAGEMENT/DISENGAGEMENT (MAX. LBS.) _____ 2.0

CONNECTOR DURABILITY (MIN. CYCLES) _____ 500

RECOMMENDED MATING TORQUE _____ 10 - 15 IN. LBS.

RECOMMENDED MOUNTING TORQUE _____ 25 - 32 IN. LBS.

4. ENVIRONMENTAL

THERMAL SHOCK _____ MIL-STD-202, METHOD 107, COND. B (-65° c TO +165° c)

SHOCK _____ MIL-STD-202, METHOD 213, COND. I (100 G's)

VIBRATION _____ MIL-STD-202, METHOD 204, COND. D (20 G's)

MOISTURE RESISTANCE _____ MIL-STD-202, METHOD 106, LESS STEP 7b

CORROSION _____ MIL-STD-202, METHOD 101, COND. B (48 HOURS)

BAROMETRIC PRESSURE (ALTITUDE) _____ MIL-STD-202, METHOD 105, COND. C (70,000 FT.) (375 VRMS)

5. MATERIAL

BODY, CLAMP NUT, HEX NUT, BUSHINGS & _____ STAINLESS STEEL PER ASTM A 582, TYPE 303, COND. A.
PRESS SLEEVE

LOCKWASHER _____ 400 SERIES STAINLESS STEEL.

CONTACTS _____ BERYLLIUM COPPER PER ASTM-B-196/B, 196M-03, COPPER
ALLOY No. UNS-C17300, TEMPER TD04.

SOLDER SLEEVE _____ BRASS PER ASTM-B-16, TEMPER H02, ALLOY C36000.

INTERFACE INSULATOR _____ TEFLON PER ASTM-D-1710-02, TYPE 1, GRADE 1, CLASS B.

REAR INSULATOR _____ CROSS LINKED POLYETHYLENE (400° F).

GASKET & O-RING _____ SILICONE RUBBER PER ZZ-R-765.

6. FINISH

BODY, CLAMP NUT, HEX NUT, BUSHINGS, _____ PASSIVATE PER AMS 2700, TYPE 2, CLASS 4.
PRESS SLEEVE & LOCKWASHER

CONTACTS _____ GOLD PER ASTM-B-488, TYPE I, CODE C, CLASS 0.75
(.000030 MIN. THK.) OVER NICKEL PER SAE AMS QQ-N-290, CLASS 1
(.000050 MIN. THK.) OVER COPPER PER AMS 2418 (.000010 MIN. THK.)

SOLDER SLEEVE _____ GOLD PER ASTM-B-488, TYPE I, CODE C, CLASS 1.27
(.000050 MIN. THK.) OVER NICKEL PER SAE AMS QQ-N-290, CLASS 1
(.000150 MIN. THK.) OVER COPPER PER AMS 2418 (.000010 MIN. THK.)

INSULATORS, GASKET & O-RING _____ N/A