

SPECIFICATION CONTROL DRAWING

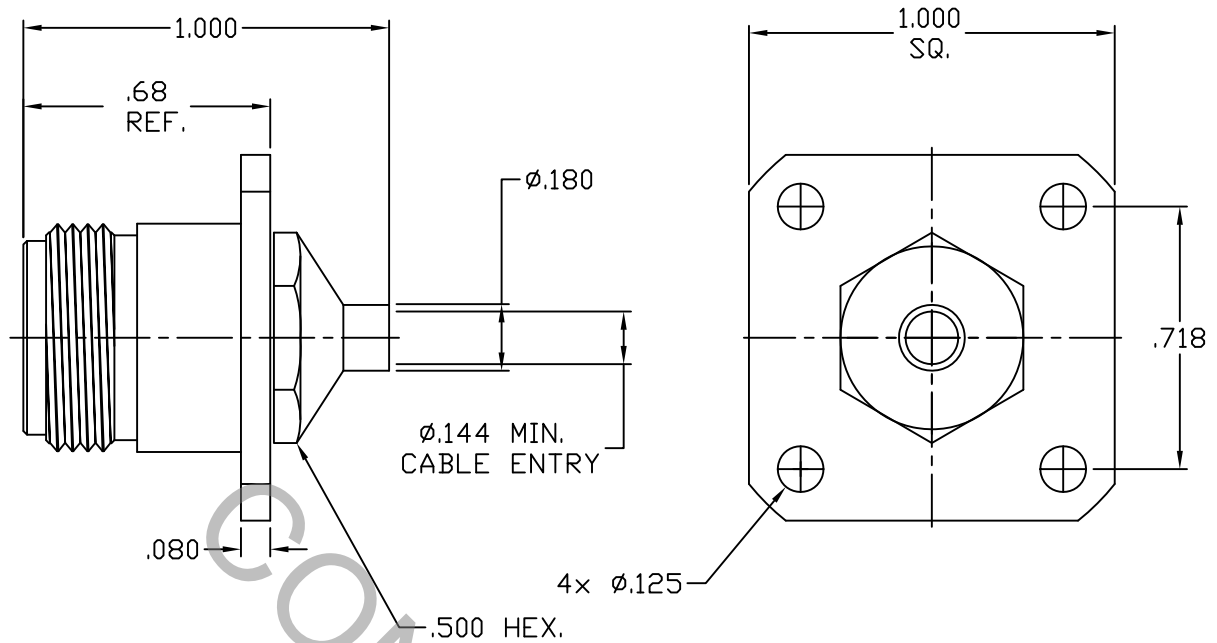

1. MATING INTERFACE DIMENSIONS Per MIL-STD-348 Fig. 304.2 (N JACK).

2. ELECTRICAL

FREQUENCY RANGE GHz	DC TO 18.0 GHz
VSWR (MAX.) *	1.06 + .005 x FGHz
INSERTION LOSS (dB MAX.) *	.05 dB x $\sqrt{\text{FGHz}}$
NOMINAL IMPEDANCE (OHMS)	50
VOLTAGE RATING (MAX. VRMS)	415
RF LEAKAGE (MIN. dB DOWN)	-100 dB - FGHz
TEMPERATURE RATING (DEGREES CENTIGRADE)	-65°c TO + 165°c
DIELECTRIC WITHSTANDING VOLTAGE (MAX. VRMS)	1,250
INSULATION RESISTANCE (MIN. MEGOHMS)	5,000
CONTACT RESISTANCE	
• CENTER CONTACT (MAX. MILLIOHMS)	1.0
• OUTER CONTACT (MAX. MILLIOHMS)	0.2

* TERMINATED IN A 50 OHM LOAD

RoHS
COMPLIANT

REV.	DCN NO.	DATE	APP.	DIMENSIONS ARE IN INCHES TOLERANCES			 HAVERHILL, MA 01835
AA	10-1059	1/19/10	TS	DECIMALS	FRACTIONAL	ANGULAR	
				.X ± .030		X ° ± 1 0'	TITLE N JACK, 4 HOLE FLANGE, SOLDER CLAMP TO Ø.141 SEMI-RIGID CABLE
				.XX ± .010	±/64	X ° X' ± 15'	
				.XXX ± .005			
				DRAWN TS	DATE 1/19/10		
				APPROVED DC	DATE 1/19/10		
				CODE IDENT.	SHEET 1 OF 2	DWG. NO.	7554-4121-2127
				2J899			

SPECIFICATION CONTROL DRAWING

3. MECHANICAL

CAPTIVATION-CENTER CONTACT

MAX AXIAL FORCE _____ 6.0 LBS.

MAX RADIAL TORQUE _____ N/A

CENTER CONTACT AXIAL FORCES

● INSERTION (MAX OUNCES) _____ INTERFACE 32.0

● WITHDRAWAL (MIN. OUNCES) _____ INTERFACE 2.0

CONNECTOR ENGAGEMENT/DISENGAGEMENT (MAX IN. LBS.) — 2.0

CONNECTOR DURABILITY (MIN. CYCLES) _____ 500

RECOMMENDED MATING TORQUE _____ 30 - 35 IN. LBS.

4. ENVIRONMENTAL

TEMPERATURE CYCLING _____ MIL-STD-202, METHOD 102, COND. C (-65° c TO + 200° c)

SHOCK _____ MIL-STD-202, METHOD 213, COND. I (100 G's)

VIBRATION _____ MIL-STD-202, METHOD 204, COND. D (20 G's)

MOISTURE RESISTANCE _____ MIL-STD-202, METHOD 106, LESS STEP 7b

CORROSION _____ MIL-STD-202, METHOD 101, COND. B (48 HOURS)

BAROMETRIC PRESSURE (ALTITUDE) _____ MIL-STD-202, METHOD 105, COND. C (70,000 FT.) (310 VRMS)

5. MATERIAL

BODY AND CLAMP NUT _____ BRASS PER ASTM-B16, TEMPER H02, ALLOY C36000.

CONTACT _____ BERYLLIUM COPPER PER ASTM B196/B, 196M-03, COPPER ALLOY No. UNS-C17300, TEMPER TD04.

INSULATOR _____ TEFLON PER ASTM D 1710-02, TYPE 1, GRADE 1, CLASS B.

O-RING _____ SILICONE RUBBER PER ZZ-R-765.

6. FINISH

BODY & CLAMP NUT _____ SILVER PER QQ-S-365, TYPE 1, GRADE A (.00015 MIN. THK) OVER NICKEL PER QQ-N-290, CLASS 1 (.000050 MIN. THK.) OVER COPPER PER MIL-C-14550, (.000010 MIN. THK)

CONTACT _____ GOLD PER ASTM B 488, TYPE I, CODE C, CLASS 2.5 (.000100 MIN. THK.) OVER NICKEL per QQ-N-290 (.000050 MIN. THK.) OVER COPPER per MIL-C-14550 (.000010 MIN. THK.)

INSULATOR & O-RING _____ N/A