

SPECIFICATION CONTROL DRAWING

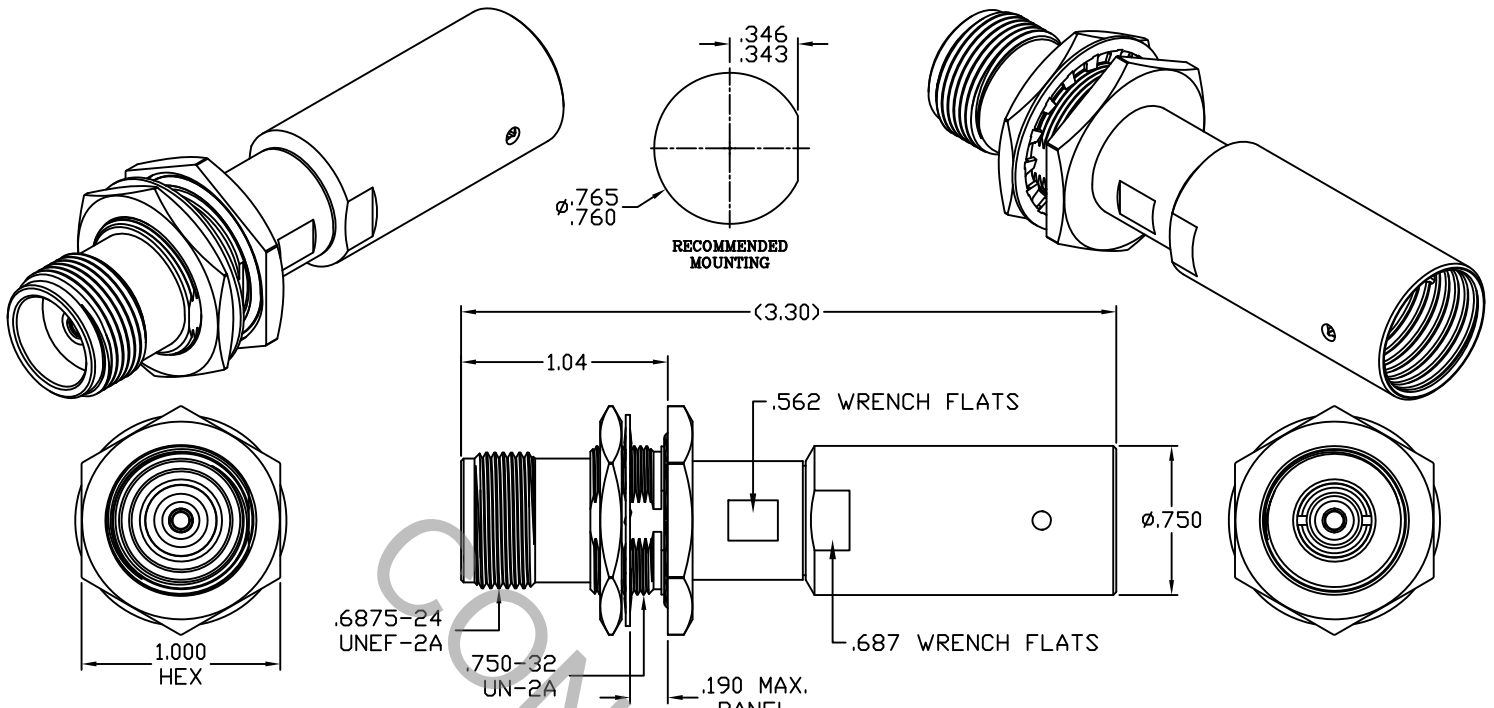

SOLD ON DYNAWAVE CABLE ASSEMBLIES ONLY

1. MATING INTERFACE DIMENSIONS Per MIL-STD-348 Fig. 309.2 (SC JACK).
2. ELECTRICAL

FREQUENCY RANGE GHz	_____	DC TO 13.0 GHz
VSWR (MAX) *	_____	1.06 + .005 x FGHz
INSERTION LOSS (dB MAX) *	_____	.06 dB x √FGHz
NOMINAL IMPEDANCE (OHMS)	_____	50
VOLTAGE RATING (MAX. VRMS)	_____	500
RF LEAKAGE (MIN. dB DOWN)	_____	-100 dB - FGHz
TEMPERATURE RATING (DEGREES CENTIGRADE)	_____	-65°C TO + 165°C
DIELECTRIC WITHSTANDING VOLTAGE (MAX. VRMS)	_____	1,500
INSULATION RESISTANCE (MIN. MEGOHMS)	_____	5,000
CONTACT RESISTANCE		
• CENTER CONTACT (MAX. MILLIOHMS)	_____	3.0
• OUTER CONTACT (MAX. MILLIOHMS)	_____	1.0

* TERMINATED IN A 50 OHM LOAD

RoHS
COMPLIANT

This Document contains proprietary and confidential information.

REV.	DCN NO.	DATE	APP.	DIMENSIONS ARE IN INCHES TOLERANCES			HAVERHILL, MA 01835	
AA	13-2297	9/25/13	DC	DECIMALS	FRACTIONAL	ANGULAR		
				.X ± .030		X ° ± 1° 0'	TITLE SC JACK, BULKHEAD, PLUG-IN, SOLDER CLAMP, DF218, ARMORED	
				.XX ± .010	± 1/64	X ° X' ± 15'		
				.XXX ± .005				
				DRAWN	RMS	DATE	9/25/13	DWG. NO. 7910-218A-6240
				APPROVED	DC	DATE	9/25/13	
				CODE IDENT.	SHEET 1 OF 2			
				6DZL5				

SPECIFICATION CONTROL DRAWING

3. MECHANICAL

CAPTIVATION-CENTER CONTACT
 MAX AXIAL FORCE _____ 6.0 LBS.
 MAX RADIAL TORQUE _____ N/A
 CENTER CONTACT AXIAL FORCES
 ● INSERTION (MAX. OUNCES) _____ N/A
 ● WITHDRAWAL (MIN. OUNCES) _____ N/A
 CONNECTOR ENGAGEMENT/DISENGAGEMENT (MAX. LBS.) _____ 2.0
 CONNECTOR DURABILITY (MIN. CYCLES) _____ 500
 RECOMMENDED MATING TORQUE _____ 20 - 23 IN. LBS.
 RECOMMENDED MOUNTING TORQUE _____ 25 - 28 IN. LBS.

4. ENVIRONMENTAL

TEMPERATURE CYCLING _____ MIL-STD-202, METHOD 107, COND. C (-65° c TO + 165° c)
 SHOCK _____ MIL-STD-202, METHOD 213, COND. I (100 G's)
 VIBRATION _____ MIL-STD-202, METHOD 204, COND. D (20 G's)
 MOISTURE RESISTANCE _____ MIL-STD-202, METHOD 106, LESS STEP 7b
 CORROSION _____ MIL-STD-202, METHOD 101, COND. B (48 HOURS)
 BAROMETRIC PRESSURE (ALTITUDE) _____ MIL-STD-202, METHOD 105, COND. C (70,000 FT.) (375 VRMS)

5. MATERIAL

BODY, HEX NUT, CLAMP NUT, BUSHING & PRESS SLEEVE _____ STAINLESS STEEL PER ASTM-A-582, TYPE 303, COND. A
 CONTACTS _____ BERYLLIUM COPPER PER ASTM-B-196/B, 196M-03, COPPER ALLOY No. UNS-C17300, TEMPER TD04.
 INSULATORS _____ TEFLON PER ASTM-D-1710-02, TYPE 1, GRADE 1, CLASS B.
 O-RINGS _____ SILICONE RUBBER PER ZZ-R-765.
 SOLDER SLEEVE _____ BRASS PER ASTM-B-16, TEMPER H02, ALLOY C36000.
 LOCKWASHER _____ 400 SERIES STAINLESS STEEL

6. FINISH

BODY, HEX NUT, LOCKWASHER, CLAMP NUT, BUSHING & PRESS SLEEVE _____ PASSIVATE PER AMS-2700, TYPE 2, CLASS 4.
 SOLDER SLEEVE _____ GOLD PER ASTM-B-488, TYPE I, CODE C, CLASS 1.27 (.000050 MIN. THK.) OVER NICKEL PER SAE-AMS-QQ-N-290 CLASS 1 (.000150 MIN. THK.) OVER COPPER PER AMS-2418 (.000010 MIN. THK.)
 CONTACTS _____ GOLD PER ASTM-B-488, TYPE I, CODE C, CLASS 0.75 (.000030 MIN. THK.) OVER NICKEL PER SAE-AMS-QQ-N-290 CLASS 1 (.000050 MIN. THK.) OVER COPPER PER AMS-2418 (.000010 MIN. THK.)
 INSULATORS & O-RINGS _____ N/A