

# SPECIFICATION CONTROL DRAWING

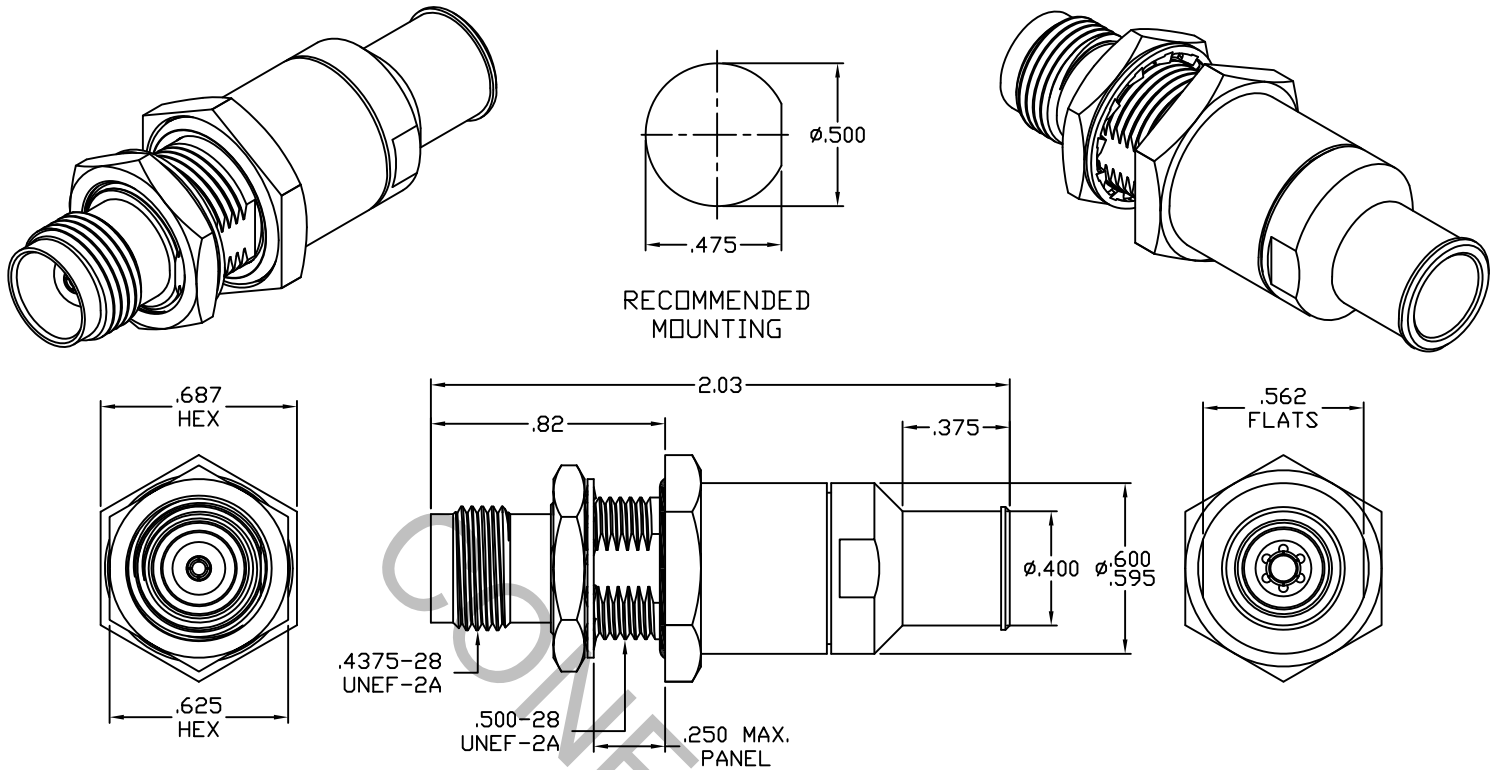

1. MATING INTERFACE DIMENSIONS Per MIL-STD-348 Fig. 313.2 (TNC JACK).

## 2. ELECTRICAL

FREQUENCY RANGE GHz	_____	DC TO 18.0 GHz
VSWR (MAX.) *	_____	1.07 + .007 x FGHz
INSERTION LOSS (dB MAX.) *	_____	.05 dB x $\sqrt{\text{FGHz}}$
NOMINAL IMPEDANCE (OHMS)	_____	50
VOLTAGE RATING (MAX. VRMS)	_____	500
RF LEAKAGE (MIN. dB DOWN)	_____	-100 dB - FGHz
TEMPERATURE RATING (DEGREES CENTIGRADE)	_____	-65°C TO + 165°C
DIELECTRIC WITHSTANDING VOLTAGE (MAX. VRMS)	_____	1,500
INSULATION RESISTANCE (MIN. MEGOHMS)	_____	5,000
CONTACT RESISTANCE		
• CENTER CONTACT (MAX. MILLIOHMS)	_____	1.5
• OUTER CONTACT (MAX. MILLIOHMS)	_____	2.0

\* TERMINATED IN A 50 OHM LOAD

This Document contains proprietary and confidential information.

**RoHS**  
COMPLIANT

REV.	DCN NO.	DATE	APP.	DIMENSIONS ARE IN INCHES TOLERANCES			CABLE INCORPORATED HAVERHILL, MA 01835
AA	18-1160	2/21/18	DC	DECIMALS	FRACTIONAL	ANGULAR	
				.X ± .030		X ° ± 1° 0'	TITLE TNC JACK, BULKHEAD, SOLDER CLAMP, PLUG-IN CONTACT, T7-0247
				.XX ± .010	± 1/64	X ° X' ± 15'	
				.XXX ± .005			
				DRAWN RMS	DATE	2/2/18	DWG. NO. 8510-7247-6240
				APPROVED DC	DATE	2/21/18	
				CODE IDENT.	SHEET 1 OF 2		
				6DZL5			

# SPECIFICATION CONTROL DRAWING

## 3. MECHANICAL

CAPTIVATION-CENTER CONTACT  
 MAX AXIAL FORCE \_\_\_\_\_ 6.0 LBS.  
 MAX RADIAL TORQUE \_\_\_\_\_ N/A  
 CENTER CONTACT AXIAL FORCES  
 ● INSERTION (MAX. OUNCES) \_\_\_\_\_ INTERFACE 32.0  
 ● WITHDRAWAL (MIN. OUNCES) \_\_\_\_\_ INTERFACE 2.0  
 CONNECTOR ENGAGEMENT/DISENGAGEMENT (MAX. LBS.) \_\_\_\_\_ 2.0  
 CONNECTOR DURABILITY (MIN. CYCLES) \_\_\_\_\_ 500  
 RECOMMENDED MATING TORQUE \_\_\_\_\_ 10 - 15 IN. LBS.  
 RECOMMENDED MOUNTING TORQUE \_\_\_\_\_ 25 - 28 IN. LBS.

## 4. ENVIRONMENTAL

THERMAL SHOCK \_\_\_\_\_ MIL-STD-202, METHOD 107, COND. B ( -65° c TO + 165° c )  
 SHOCK \_\_\_\_\_ MIL-STD-202, METHOD 213, COND. I (100 G's)  
 VIBRATION \_\_\_\_\_ MIL-STD-202, METHOD 204, COND. D (20 G's)  
 MOISTURE RESISTANCE \_\_\_\_\_ MIL-STD-202, METHOD 106, LESS STEP 7b  
 CORROSION \_\_\_\_\_ MIL-STD-202, METHOD 101, COND. B (48 HOURS)  
 BAROMETRIC PRESSURE (ALTITUDE) \_\_\_\_\_ MIL-STD-202, METHOD 105, COND. C ( 70,000 FT. ) ( 375 VRMS )

## 5. MATERIAL

BODY, CLAMP NUT, HEX NUT, BUSHING & \_\_\_\_\_ STAINLESS STEEL PER ASTM A 582, TYPE 303, COND. A.  
 PRESS SLEEVE  
 CONTACTS \_\_\_\_\_ BERYLLIUM COPPER PER ASTM-B-196/B, 196M-03, COPPER  
 ALLOY No. UNS-C17300, TEMPER TD04.  
 INTERFACE INSULATOR \_\_\_\_\_ TEFLON PER ASTM-D-1710, TYPE 1, GRADE 1, CLASS B.  
 REAR INSULATOR \_\_\_\_\_ CROSS LINKED POLYETHYLENE  
 SOLDER SLEEVE \_\_\_\_\_ BRASS PER ASTM B16, TEMPER H02, ALLOY C36000  
 O-RINGS \_\_\_\_\_ SILICONE RUBBER PER ZZ-R-765.  
 LOCKWASHER \_\_\_\_\_ 304 STAINLESS STEEL

## 6. FINISH

BODY, CLAMP NUT, HEX NUT, BUSHING, \_\_\_\_\_ PASSIVATE PER AMS-2700, TYPE 2, CLASS 4.  
 PRESS SLEEVE & LOCKWASHER  
 CONTACTS \_\_\_\_\_ GOLD PER ASTM-B-488, TYPE I, CODE C, CLASS 0.75  
 (.000030 MIN. THK.) OVER NICKEL per SAE-AMS-QQ-N-290,  
 CLASS 1 (.000050 MIN. THK.) OVER COPPER per AMS-2418  
 (.000010 MIN. THK.)  
 SOLDER SLEEVE \_\_\_\_\_ GOLD PER ASTM-B-488, TYPE I, CODE C, CLASS 1.27  
 (.000050 MIN. THK.) OVER NICKEL per SAE-AMS-QQ-N-290,  
 CLASS 1 (.000150 MIN. THK.) OVER COPPER per AMS-2418  
 (.000010 MIN. THK.)  
 INSULATORS & O-RINGS \_\_\_\_\_ N/A