

SPECIFICATION CONTROL DRAWING

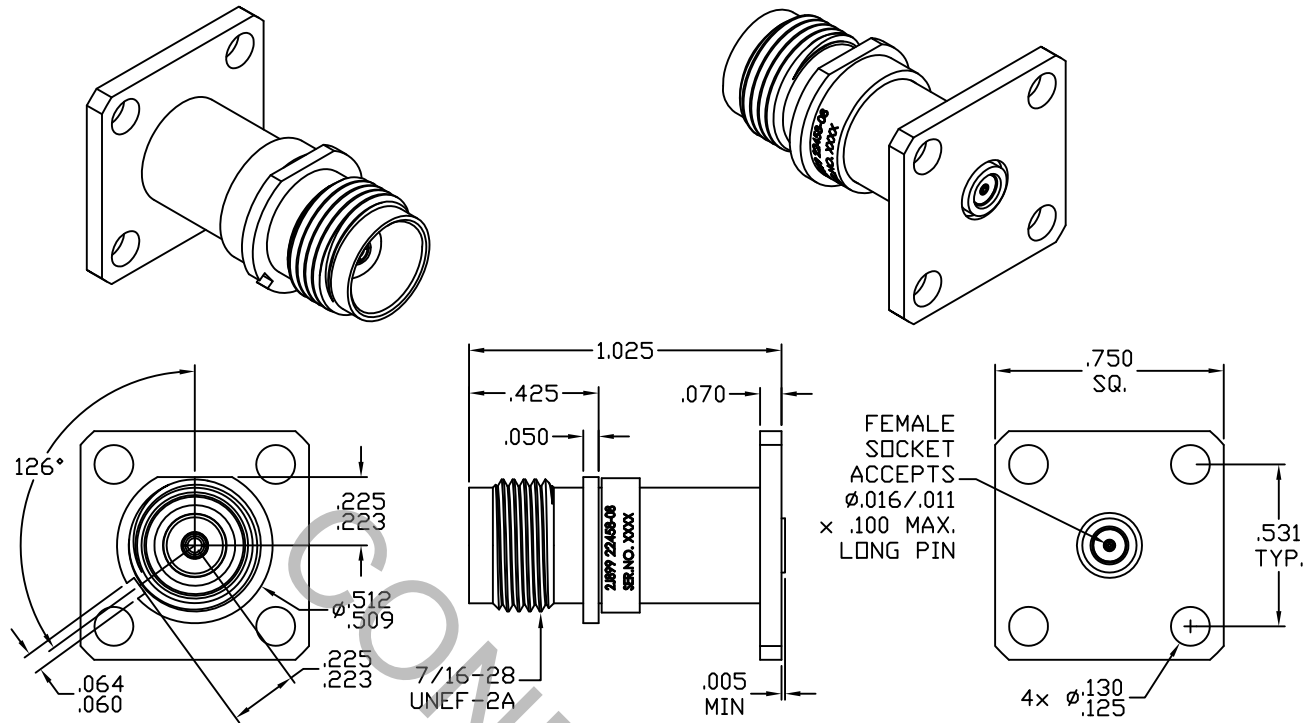

1. MATING INTERFACE DIMENSIONS Per MIL-STD-348 Fig. 313.2 (TNC JACK).

2. ELECTRICAL

| | | |
|---------------------------------------------|-------|-------------------------------|
| FREQUENCY RANGE GHz | _____ | DC TO 18.0 GHz |
| VSWR (MAX.) * | _____ | 1.13 + .012 x FGHz |
| INSERTION LOSS (dB MAX.) * | _____ | .05 dB x $\sqrt{\text{FGHz}}$ |
| NOMINAL IMPEDANCE (OHMS) | _____ | 50 |
| VOLTAGE RATING (MAX. VRMS) | _____ | 250 |
| RF LEAKAGE (MIN. dB DOWN) | _____ | -100 dB - FGHz |
| TEMPERATURE RATING (DEGREES CENTIGRADE) | _____ | -65°C TO + 165°C |
| DIELECTRIC WITHSTANDING VOLTAGE (MAX. VRMS) | _____ | 750 |
| INSULATION RESISTANCE (MIN. MEGOHMS) | _____ | 5,000 |
| CONTACT RESISTANCE | | |
| • CENTER CONTACT (MAX. MILLIOHMS) | _____ | 6.0 |
| • OUTER CONTACT (MAX. MILLIOHMS) | _____ | 2.0 |

* TERMINATED IN A 50 OHM LOAD

RoHS
COMPLIANT

| REV. | DCN NO. | DATE | APP. | DIMENSIONS ARE IN INCHES TOLERANCES | | | HAVERHILL, MA 01835 |
|------|---------|---------|------|----------------------------------------|--------------|----------------------------|--------------------------------------------------------------------------------------|
| AA | 10-1733 | 8/11/10 | TS | DECIMALS | FRACTIONAL | ANGULAR | |
| AB | 11-1255 | 3/18/11 | DC | .X ± .030 .XX ± .010 .XXX ± .005 | ± 1/64 | X ° ± 1'0" X ° X' ± 15' | |
| | | | | DRAWN | TS | DATE | 8/11/10 |
| | | | | APPROVED | DC | DATE | 8/11/10 |
| | | | | CODE IDENT. | | | TITLE TNC JACK, 4 HOLE FLANGE, KEYED FLANGE, EMI, ACCEPTS 0.016/.011 PIN |
| | | | | 2J899 | SHEET 1 OF 2 | DWG. NO. | |

SPECIFICATION CONTROL DRAWING

3. MECHANICAL

CAPTIVATION-CENTER CONTACT

MAX AXIAL FORCE _____ 4.5 LBS.

MAX RADIAL TORQUE _____ N/A

CENTER CONTACT AXIAL FORCES

● INSERTION (MAX OUNCES) _____ INTERFACE 32.0, REAR * 32.0 *

● WITHDRAWAL (MIN. OUNCES) _____ INTERFACE 2.0, REAR * 1.0 *

CONNECTOR ENGAGEMENT/DISENGAGEMENT (MAX LBS.) _____ 2.0

CONNECTOR DURABILITY (MIN. CYCLES) _____ 500

RECOMMENDED MATING TORQUE _____ 7 - 10 IN. LBS.

* WHEN TESTED TO .012 ±.001 OR .015 ±.001 FEED THRU SIZE *

4. ENVIRONMENTAL

TEMPERATURE CYCLING _____ MIL-STD-202, METHOD 107, COND. C (-65° c TO +165° c)

SHOCK _____ MIL-STD-202, METHOD 213, COND. I (100 G's)

VIBRATION _____ MIL-STD-202, METHOD 204, COND. D (20 G's)

MOISTURE RESISTANCE _____ MIL-STD-202, METHOD 106, LESS STEP 7b

CORROSION _____ MIL-STD-202, METHOD 101, COND. B (48 HOURS)

BAROMETRIC PRESSURE (ALTITUDE) _____ MIL-STD-202, METHOD 105, COND. C (70,000 FT.) (190 VRMS)

5. MATERIAL

BODY _____ STAINLESS STEEL PER ASTM-A-582, TYPE 303, COND. A

CONTACT _____ BERYLLIUM COPPER PER ASTM-B-196/B, 196M-03, COPPER ALLOY No. UNS-C17300, TEMPER TD04.

INSULATOR _____ TEFLON PER ASTM-D-1710-02, TYPE 1, GRADE 1, CLASS B.

EMI GASKET _____ SILVER PLATED ALUMINUM IN SILICONE PER MIL-G-83528, TYPE B.

MARKER _____ MIL-DTL-23053/5, WHITE

6. FINISH

BODY _____ PASSIVATE PER AMS-2700, TYPE 2, CLASS 4.

CONTACT _____ GOLD PER ASTM-B-488, TYPE I, CODE C, CLASS 1.27 (.000050 MIN. THK.) OVER NICKEL PER SAE-AMS-QQ-N-290 CLASS 1 (.000050 MIN. THK.) OVER COPPER PER AMS-2418 (.000010 MIN. THK.)

INSULATOR & MARKER _____ N/A