

SPECIFICATION CONTROL DRAWING

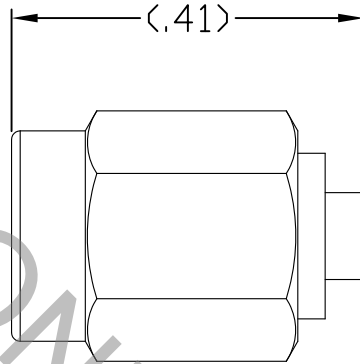

∅.051
CABLE
ENTRY

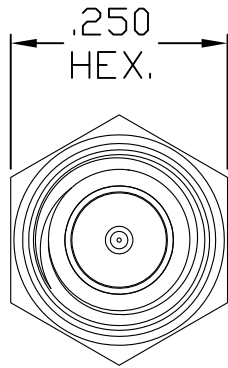
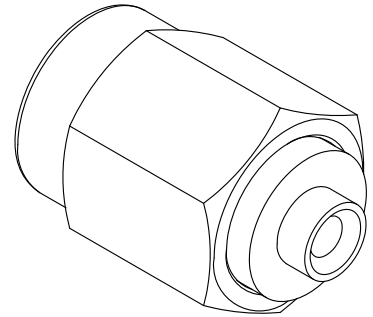
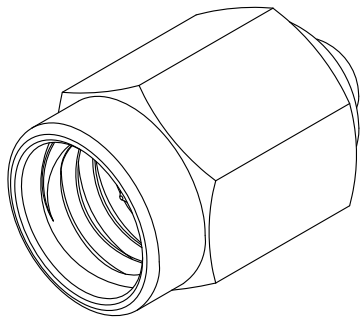
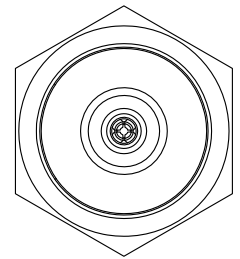

1. MATING INTERFACE DIMENSIONS Per MIL-STD-348 Fig. 319.1 (SSMA PLUG).

2. ELECTRICAL

FREQUENCY RANGE GHz	_____	DC TO 36.0 GHz
VSWR (MAX.) *	_____	1.05 + .010 x FGHz
INSERTION LOSS (dB MAX.) *	_____	.05 dB x √FGHz
NOMINAL IMPEDANCE (OHMS)	_____	50
VOLTAGE RATING (MAX. VRMS)	_____	170
RF LEAKAGE (MIN. dB DOWN)	_____	-100 dB - FGHz
TEMPERATURE RATING (DEGREES CENTIGRADE)	_____	-65°c TO + 165°c
DIELECTRIC WITHSTANDING VOLTAGE (MAX. VRMS)	_____	500
INSULATION RESISTANCE (MIN. MEGOHMS)	_____	5,000
CONTACT RESISTANCE		
• CENTER CONTACT (MAX. MILLIOHMS)	_____	3.0
• OUTER CONTACT (MAX. MILLIOHMS)	_____	2.0

* TERMINATED IN A 50 OHM LOAD

This Document contains proprietary and confidential information.

RoHS
COMPLIANT

REV.	DCN NO.	DATE	APP.	DIMENSIONS ARE IN INCHES TOLERANCES			 HAVERHILL, MA 01835
				DECIMALS	FRACTIONAL	ANGULAR	
AA	08-1012	1/3/08	DC	.X ± .030		X ° ± 1° 0'	
AB	14-1742	10/10/14	DC	.XX ± .010 .XXX ± .005	± 1/64	X ° X' ± 15'	
				DRAWN DC	DATE	1/3/08	TITLE SSMA PLUG DIRECT SOLDER TO ∅.047 SEMI-RIGID CABLE
				APPROVED DC	DATE	1/3/08	
				CODE IDENT.	SHEET 1 OF 2		DWG. NO. 9200-4721-6200
				2J899			

SPECIFICATION CONTROL DRAWING

3. MECHANICAL

CAPTIVATION-CENTER CONTACT

MAX AXIAL FORCE _____ 4.0 LBS.

MAX RADIAL TORQUE _____ N/A

CENTER CONTACT AXIAL FORCES

● INSERTION (MAX. OUNCES) _____ N/A

● WITHDRAWAL (MIN. OUNCES) _____ N/A

CONNECTOR ENGAGEMENT/DISENGAGEMENT (MAX. LBS.) _____ 2.0

CONNECTOR DURABILITY (MIN. CYCLES) _____ 500

RECOMMENDED MATING TORQUE _____ 5 - 8 IN. LBS.

4. ENVIRONMENTAL

TEMPERATURE CYCLING _____ MIL-STD-202, METHOD 102, COND. C (-65° c TO + 165° c)

SHOCK _____ MIL-STD-202, METHOD 213, COND. I (100 G's)

VIBRATION _____ MIL-STD-202, METHOD 204, COND. D (20 G's)

MOISTURE RESISTANCE _____ MIL-STD-202, METHOD 106, LESS STEP 7b

CORROSION _____ MIL-STD-202, METHOD 101, COND. B (48 HOURS)

BAROMETRIC PRESSURE (ALTITUDE) _____ MIL-STD-202, METHOD 105, COND. C (70,000 FT.) (125 VRMS)

5. MATERIAL

BODY & COUPLING NUT _____ STAINLESS STEEL PER ASTM-A-582, TYPE 303, COND. A

CONTACT & RETAINING RING _____ BERYLLIUM COPPER PER ASTM-B-196-90, COPPER ALLOY
No. UNS-C17300, TEMPER TD04.

INSULATOR _____ TEFLON PER ASTM-D-1710-02, TYPE 2, GRADE 1, CLASS A.

GASKET _____ SILICONE RUBBER PER ZZ-R-765.

6. FINISH

COUPLING NUT _____ PASSIVATE PER AMS-2700, TYPR 2, CLASS 4

BODY _____ GOLD PER ASTM-B-488, TYPE I, CODE C, CLASS 1.27
(.000050 MIN. THK.) OVER NICKEL per SAE-AMS-QQ-N-290
CLASS 1 (.000150 MIN. THK.) OVER NICKEL (WOODS OR WATTS)
(.000010 MIN. THK.)

CONTACT _____ GOLD PER ASTM-B-488, TYPE I, CODE C, CLASS 1.27
(.000050 MIN. THK.) OVER NICKEL per SAE-AMS-QQ-N-290
CLASS 1 (.000050 MIN. THK.) OVER COPPER AMS-2418
(.000010 MIN. THK.)

INSULATOR, RETAINING RING & GASKET _____ N/A