

# SPECIFICATION CONTROL DRAWING

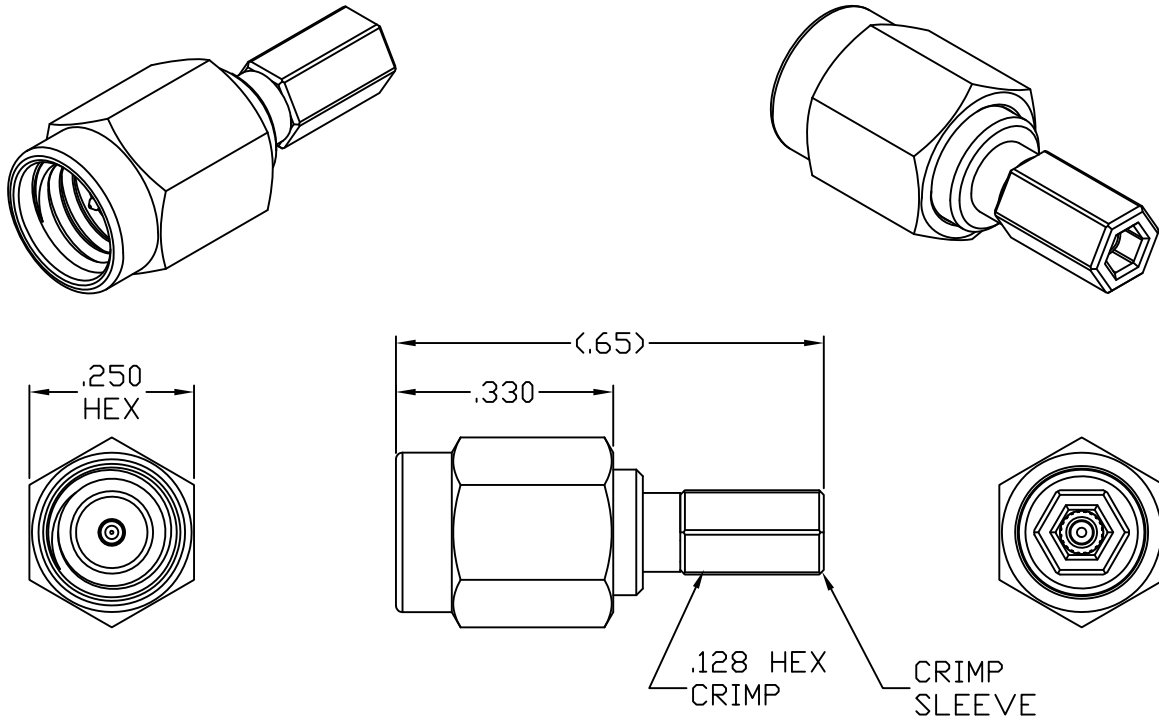

1. MATING INTERFACE DIMENSIONS Per MIL-STD-348 Fig. 319.1 (SSMA PLUG).

## 2. ELECTRICAL

FREQUENCY RANGE GHz	_____	DC TO 12.4 GHz
VSWR (MAX) *	_____	1.06 + .010 x FGHz
INSERTION LOSS (dB MAX) *	_____	.10 dB x $\sqrt{\text{FGHz}}$
NOMINAL IMPEDANCE (OHMS)	_____	50
VOLTAGE RATING (MAX. VRMS)	_____	165
RF LEAKAGE (MIN. dB DOWN)	_____	-100 dB - FGHz
TEMPERATURE RATING (DEGREES CENTIGRADE)	_____	-65°C TO + 165°C
DIELECTRIC WITHSTANDING VOLTAGE (MAX. VRMS)	_____	500
INSULATION RESISTANCE (MIN. MEGOHMS)	_____	5,000
CONTACT RESISTANCE		
• CENTER CONTACT (MAX. MILLIOHMS)	_____	2.0
• OUTER CONTACT (MAX. MILLIOHMS)	_____	2.0

\* TERMINATED IN A 50 OHM LOAD

**RoHS**  
COMPLIANT

This Document contains proprietary and confidential information.

REV.	DCN NO.	DATE	APP.	DIMENSIONS ARE IN INCHES TOLERANCES			 HAVERHILL, MA 01835
				DECIMALS	FRACTIONAL	ANGULAR	
AA	13-1976	7/15/13	TS	.X ± .030 .XX ± .010 .XXX ± .005	± 1/64	X ° ± 1' 0" X ° X' ± 15'	
AB	14-1742	10/10/14	DC				
AC	16-1462	4/12/16	DC	DRAWN TS	DATE 7/15/13	TITLE SSMA PLUG, STRAIGHT, CRIMP ATTACHMENT RG178 CABLE	
				APPROVED DC	DATE 7/15/13		
				CODE IDENT. 2J899	SHEET 1 OF 2		
						DWG. NO. 9200-7830-6200	

# SPECIFICATION CONTROL DRAWING

## 3. MECHANICAL

### CAPTIVATION-CENTER CONTACT

MAX AXIAL FORCE \_\_\_\_\_ N/A

MAX RADIAL TORQUE \_\_\_\_\_ N/A

### CENTER CONTACT AXIAL FORCES

● INSERTION (MAX. OUNCES) \_\_\_\_\_ N/A

● WITHDRAWAL (MIN. OUNCES) \_\_\_\_\_ N/A

CONNECTOR ENGAGEMENT/DISENGAGEMENT (MAX. LBS.) \_\_\_\_\_ 2.0

CONNECTOR DURABILITY (MIN. CYCLES) \_\_\_\_\_ 500

RECOMMENDED MATING TORQUE \_\_\_\_\_ 5 - 8 IN. LBS.

## 4. ENVIRONMENTAL

TEMPERATURE CYCLING \_\_\_\_\_ MIL-STD-202, METHOD 102, COND. C ( -65° c TO + 200° c )

SHOCK \_\_\_\_\_ MIL-STD-202, METHOD 213, COND. I (100 G's)

VIBRATION \_\_\_\_\_ MIL-STD-202, METHOD 204, COND. D (20 G's)

MOISTURE RESISTANCE \_\_\_\_\_ MIL-STD-202, METHOD 106, LESS STEP 7b

CORROSION \_\_\_\_\_ MIL-STD-202, METHOD 101, COND. B (48 HOURS)

BAROMETRIC PRESSURE (ALTITUDE) \_\_\_\_\_ MIL-STD-202, METHOD 105, COND. C ( 70,000 FT. ) ( 125 VRMS )

## 5. MATERIAL

BODY & COUPLING NUT \_\_\_\_\_ STAINLESS STEEL PER ASTM-A-582, TYPE 303, COND. A

CONTACT & RETAINING RING \_\_\_\_\_ BERYLLIUM COPPER PER ASTM B196/B, 196M-03, COPPER ALLOY No. UNS-C17300, TEMPER TD04.

INSULATOR \_\_\_\_\_ TEFLON PER ASTM D 1710-02, TYPE 1, GRADE 1, CLASS B.

GASKET \_\_\_\_\_ SILICONE RUBBER PER ZZ-R-765.

CRIMP SLEEVE \_\_\_\_\_ OFHC COPPER

SHRINK SLEEVE \_\_\_\_\_ MIL-DTL-23053/4-102-0 (RIGID 3:1)

## 6. FINISH

BODY & COUPLING NUT \_\_\_\_\_ PASSIVATE PER AMS 2700, TYPE 2, CLASS 4.

CRIMP SLEEVE \_\_\_\_\_ NICKEL PER SAE AMS Q-N-290, CLASS 1 (.000200 MIN. THK.)  
OVER COPPER PER AMS 2418 (.000010 MIN. THK.)

CONTACT \_\_\_\_\_ GOLD PER ASTM-B-488, TYPE I, CODE C, CLASS 1.27  
(.000050 MIN. THK.) OVER NICKEL PER SAE AMS QQ-N-290, CLASS 1  
(.000050 MIN. THK.) OVER COPPER PER AMS 2418 (.000010 MIN. THK.)

INSULATOR, RETAINING RING, GASKET \_\_\_\_\_ N/A  
AND SHRINK SLEEVE