

SPECIFICATION CONTROL DRAWING

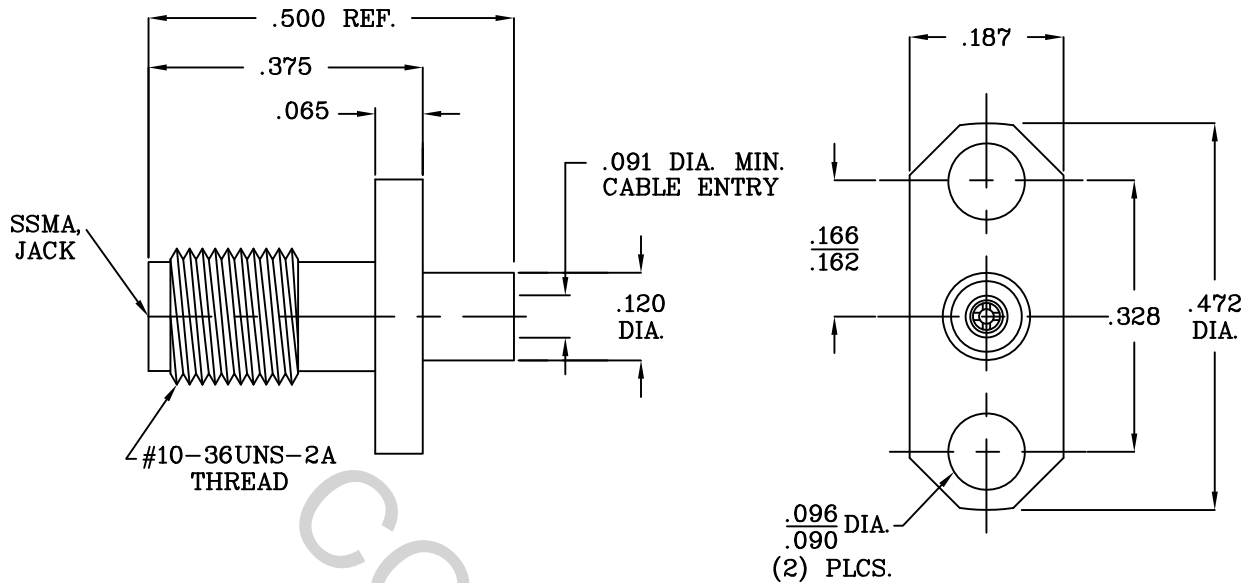

1. MATING INTERFACE DIMENSIONS Per MIL-STD-348 Fig. 319.2 (SSMA JACK).

2. ELECTRICAL

FREQUENCY RANGE GHz	_____	DC TO 36.0 GHz
VSWR (MAX) *	_____	1.10 + .012 x FGHz
INSERTION LOSS (dB MAX) *	_____	.04 dB x $\sqrt{\text{FGHz}}$
NOMINAL IMPEDANCE (OHMS)	_____	50
VOLTAGE RATING (MAX. VRMS)	_____	120
RF LEAKAGE (MIN. dB DOWN)	_____	-100 dB - FGHz
TEMPERATURE RATING (DEGREES CENTIGRADE)	_____	-65°C TO + 165°C
DIELECTRIC WITHSTANDING VOLTAGE (MAX. VRMS)	_____	350
INSULATION RESISTANCE (MIN. MEGOHMS)	_____	1,000
CONTACT RESISTANCE		
• CENTER CONTACT (MAX. MILLIOHMS)	_____	6.0
• OUTER CONTACT (MAX. MILLIOHMS)	_____	2.0

* TERMINATED IN A 50 OHM LOAD

This Document contains proprietary and confidential information.

RoHS
COMPLIANT

REV.	DCN NO.	DATE	APP.	DIMENSIONS ARE IN INCHES TOLERANCES			INCORPORATED HAVERHILL, MA 01835	
AA	06-1163	2/10/06	DC	DECIMALS	FRACTIONAL	ANGULAR		
AB	18-1858	8/7/18	DC	.X ± .030 .XX ± .010 .XXX ± .005	± 1/64	X° ± 1'0" XX' ± 15'		
				DRAWN	SS	DATE	2/10/06	TITLE SSMA, JACK 2 HOLE FLANGE CAPTIVATED CONTACT .085 SEMI-RIGID CABLE
				APPROVED	DC	DATE	2/10/06	
				CODE IDENT.	SHEET 1 OF 2		DWG. NO.	9352-8525-6440
				2J899				

SPECIFICATION CONTROL DRAWING

3. MECHANICAL

CAPTIVATION-CENTER CONTACT

MIN. AXIAL FORCE _____ 4.5 LBS.

MIN. RADIAL TORQUE _____ N/A

CENTER CONTACT AXIAL FORCES

● INSERTION (MAX. OUNCES) _____ INTERFACE 32.0

● WITHDRAWAL (MIN. OUNCES) _____ INTERFACE 1.5

CONNECTOR ENGAGEMENT/DISENGAGEMENT (MAX. LBS.) _____ 2.0

CONNECTOR DURABILITY (MIN. CYCLES) _____ 500

RECOMMENDED MATING TORQUE _____ 6 - 8 IN. LBS.

4. ENVIRONMENTAL

TEMPERATURE CYCLING _____ MIL-STD-202, METHOD 107, COND. C (-65° c TO + 165° c)

SHOCK _____ MIL-STD-202, METHOD 213, COND. I (100 G's)

VIBRATION _____ MIL-STD-202, METHOD 204, COND. D (20 G's)

MOISTURE RESISTANCE _____ MIL-STD-202, METHOD 106, LESS STEP 7b

CORROSION _____ MIL-STD-202, METHOD 101, COND. B (48 HOURS)

BAROMETRIC PRESSURE (ALTITUDE) _____ MIL-STD-202, METHOD 105, COND. C (70,000 FT.) (90 VRMS)

5. MATERIAL

BODY _____ STAINLESS STEEL PER ASTM-A-582, TYPE 303, COND. A

CONTACT _____ BERYLLIUM COPPER PER ASTM-B-196/B, 196M-03, COPPER ALLOY No. UNS-C17300, TEMPER TD04.

INSULATOR _____ TEFLON PER ASTM-D-1710, TYPE 1, GRADE 1, CLASS B.

SPACER _____ TEFLON (TFE RESIN) WITH 15% GLASS FIBER

6. FINISH

BODY _____ GOLD PER ASTM-B-488, TYPE II, CODE C, CLASS 1.27
(.000050 MIN. THK.) OVER NICKEL PER SAE-AMS-QQ-N-290
CLASS 1 (.000150 MIN. THK.) OVER NICKEL (WOODS OR WATTS)
(.000010 MIN. THK.)

CONTACT _____ GOLD PER ASTM-B-488, TYPE II, CODE C, CLASS 1.27
(.000050 MIN. THK.) OVER NICKEL PER SAE-AMS-QQ-N-290
CLASS 1 (.000050 MIN. THK.) OVER COPPER PER AMS-2418
(.000010 MIN. THK.)

INSULATOR AND SPACER _____ N/A