

SPECIFICATION CONTROL DRAWING

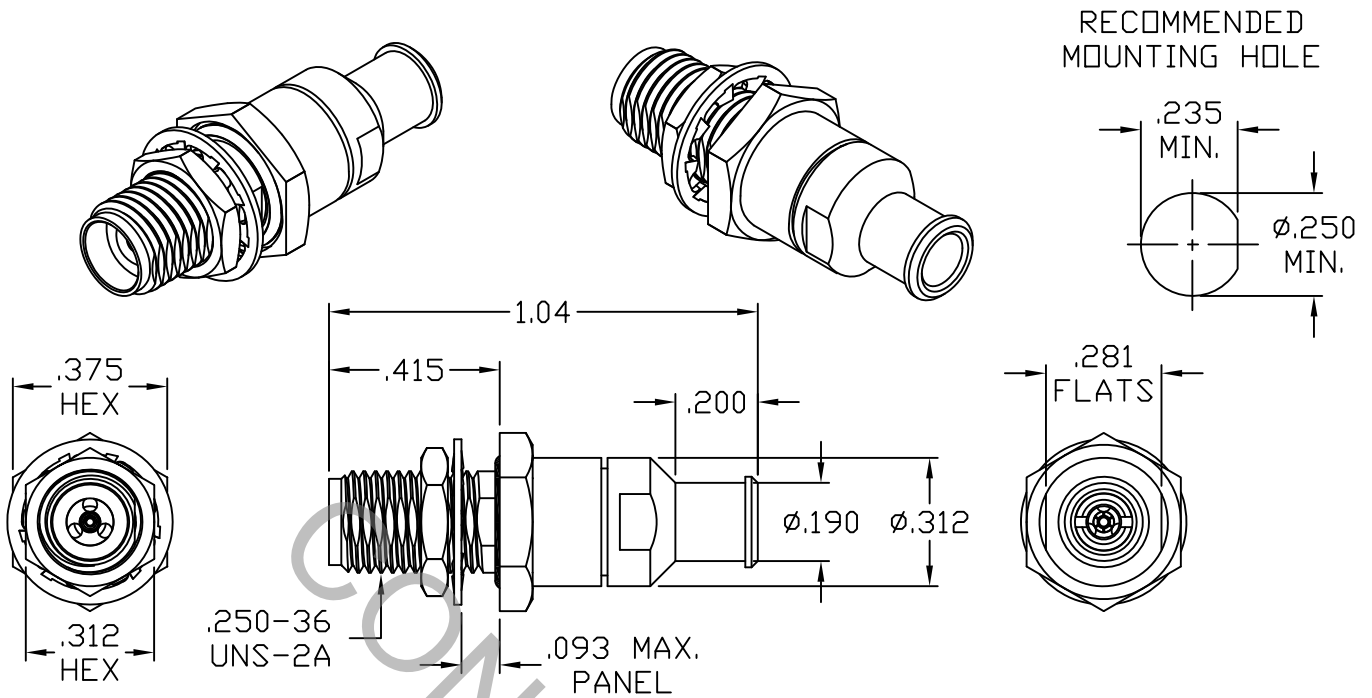

1. MATING INTERFACE DIMENSIONS Per MIL-STD-348 Fig. 323.2 (SMK JACK).

2. ELECTRICAL

FREQUENCY RANGE GHz	DC TO 40.0 GHz
VSWR (MAX.) *	1.04 + .005 x FGHz
INSERTION LOSS (dB MAX.) *	.05 dB x $\sqrt{\text{FGHz}}$
NOMINAL IMPEDANCE (OHMS)	50
VOLTAGE RATING (MAX. VRMS)	250
RF LEAKAGE (MIN. dB DOWN)	-100 dB - FGHz
TEMPERATURE RATING (DEGREES CENTIGRADE)	-65°C TO + 125°C
DIELECTRIC WITHSTANDING VOLTAGE (MAX. VRMS)	750
INSULATION RESISTANCE (MIN. MEGOHMS)	5,000
CONTACT RESISTANCE	
• CENTER CONTACT (MAX. MILLIOHMS)	6.0
• OUTER CONTACT (MAX. MILLIOHMS)	2.0

* TERMINATED IN A 50 OHM LOAD

This Document contains proprietary and confidential information.

RoHS
COMPLIANT

REV.	DCN NO.	DATE	APP.	DIMENSIONS ARE IN INCHES TOLERANCES			 HAVERHILL, MA 01835	
AA	13-2064	7/30/13	DC	DECIMALS	FRACTIONAL	ANGULAR		
				.X ± .030		X ° ± 1° 0'	TITLE 2.92mm JACK, BULKHEAD, SOLDER CLAMP, PLUG-IN CONTACT, DF150 LOW LOSS	
				.XX ± .010	± 1/64	X ° X' ± 15'		
				.XXX ± .005				
				DRAWN	DC	DATE	7/30/13	DWG. NO. 9510-150H-6240
				APPROVED	DC	DATE	7/30/13	
				CODE IDENT.	SHEET 1 OF 2			
				6DZL5				

SPECIFICATION CONTROL DRAWING

3. MECHANICAL

CAPTIVATION-CENTER CONTACT

MIN. AXIAL FORCE _____ 4.5 LBS.

MIN. RADIAL TORQUE _____ N/A

CENTER CONTACT AXIAL FORCES

● INSERTION (MAX. OUNCES) _____ INTERFACE 32.0

● WITHDRAWAL (MIN. OUNCES) _____ INTERFACE 2.0

CONNECTOR ENGAGEMENT/DISENGAGEMENT (MAX. LBS.) _____ 2.0

CONNECTOR DURABILITY (MIN. CYCLES) _____ 500

RECOMMENDED MATING TORQUE _____ 7 - 10 IN. LBS.

RECOMMENDED MOUNTING TORQUE _____ 22 - 28 IN. LBS.

4. ENVIRONMENTAL

TEMPERATURE CYCLING _____ MIL-STD-202, METHOD 107, COND. C (-65° c TO + 125° c)

SHOCK _____ MIL-STD-202, METHOD 213, COND. I (100 G's)

VIBRATION _____ MIL-STD-202, METHOD 204, COND. D (20 G's)

MOISTURE RESISTANCE _____ MIL-STD-202, METHOD 106, LESS STEP 7b

CORROSION _____ MIL-STD-202, METHOD 101, COND. B (48 HOURS)

BAROMETRIC PRESSURE (ALTITUDE) _____ MIL-STD-202, METHOD 105, COND. C (70,000 FT.) (190 VRMS)

5. MATERIAL

BODY BUSHING, CLAMP NUT & HEX NUT _____ STAINLESS STEEL PER ASTM-A-582, TYPE 303, COND. A

CONTACTS _____ BERYLLIUM COPPER PER ASTM-B-196/B, 196M-03, COPPER ALLOY No. UNS-C17300, TEMPER TD04.

INSULATOR _____ PLASTIC COMPOSITE

O-RINGS _____ SILICONE RUBBER PER ZZ-R-765.

LOCKWASHER _____ 400 SERIES STAINLESS STEEL

SOLDER SLEEVE _____ BRASS PER ASTM-B-16, TEMPER H02, ALLOY C36000.

6. FINISH

BODY, BUSHING, CLAMP NUT, HEX NUT _____ PASSIVATE PER AMS-2700, TYPE 2, CLASS 4.
& LOCKWASHER

CONTACT & SOLDER SLEEVE _____ GOLD PER ASTM-B-488, TYPE I, CODE C, CLASS 0.75
(.000030 MIN. THK.) OVER NICKEL PER SAE-AMS-QQ-N-290
CLASS 1 (.000050 MIN. THK.) OVER COPPER PER AMS-2418
(.000010 MIN. THK.)

INSULATOR & O-RINGS _____ N/A