

SPECIFICATION CONTROL DRAWING

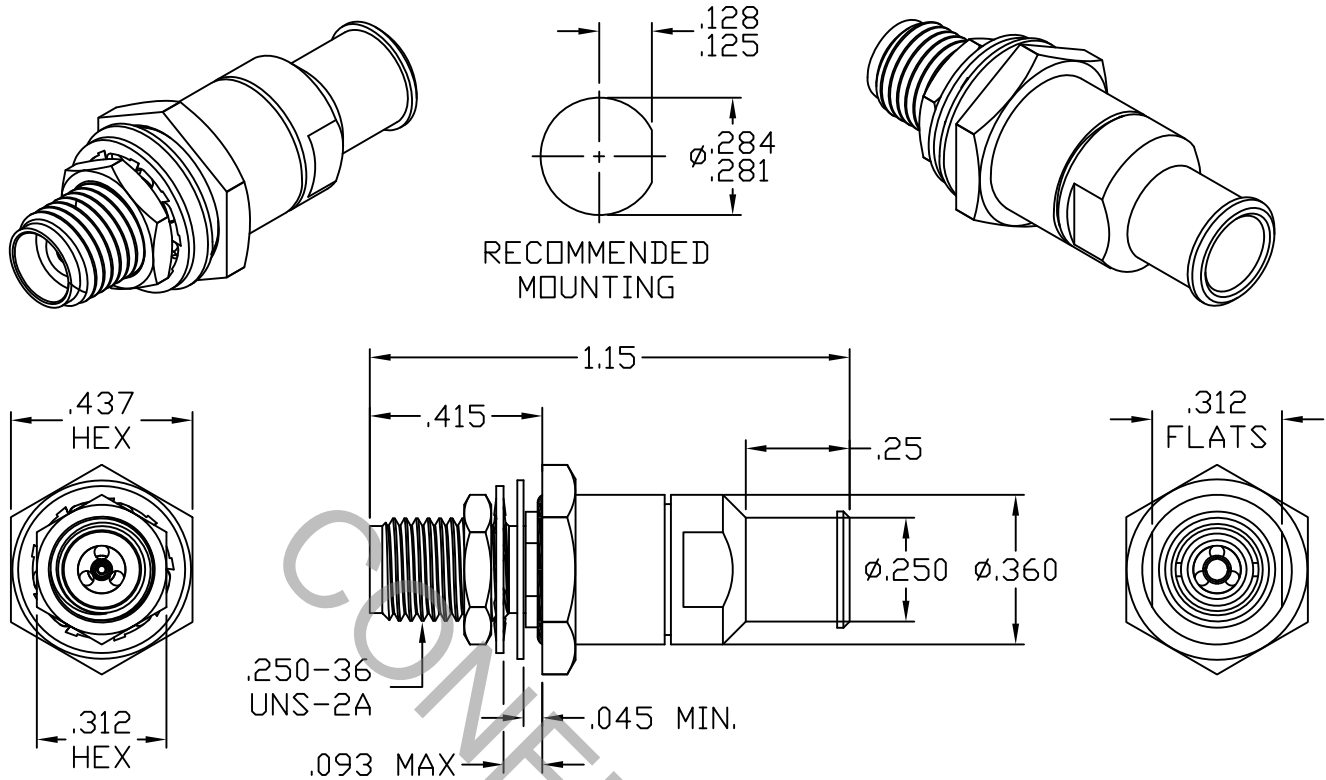

1. MATING INTERFACE DIMENSIONS Per MIL-STD-348 Fig. 323.2 (SMK JACK).

2. ELECTRICAL

FREQUENCY RANGE GHz	_____	DC TO 33.0 GHz
VSWR (MAX) *	_____	1.04 + .005 x FGHz
INSERTION LOSS (dB MAX) *	_____	.05 dB x $\sqrt{\text{FGHz}}$
NOMINAL IMPEDANCE (OHMS)	_____	50
VOLTAGE RATING (MAX. VRMS)	_____	250
RF LEAKAGE (MIN. dB DOWN)	_____	-100 dB - FGHz
TEMPERATURE RATING (DEGREES CENTIGRADE)	_____	-65°C TO + 125°C
DIELECTRIC WITHSTANDING VOLTAGE (MAX. VRMS)	_____	750
INSULATION RESISTANCE (MIN. MEGOHMS)	_____	5,000
CONTACT RESISTANCE		
• CENTER CONTACT (MAX. MILLIOHMS)	_____	6.0
• OUTER CONTACT (MAX. MILLIOHMS)	_____	2.0

* TERMINATED IN A 50 OHM LOAD

This Document contains proprietary and confidential information.

RoHS
COMPLIANT

REV.	DCN NO.	DATE	APP.	DIMENSIONS ARE IN INCHES TOLERANCES			 CABLE INCORPORATED HAVERHILL, MA 01835
				DECIMALS	FRACTIONAL	ANGULAR	
AA	15-1651	4/30/15	DC	.X ± .030		X ° ± 1° 0'	
AB	15-1668	5/1/15	DC	.XX ± .010	± 1/64	X ° X' ± 15'	
				DRAWN	RMS	DATE 4/29/15	
				APPROVED	DC	DATE 4/30/15	
				CODE IDENT.	SHEET 1 OF 2		
				6DZL5	DWG. NO. 9510-232H-6245		

TITLE
2.92mm JACK, BULKHEAD,
SOLDER CLAMP, PLUG-IN
CONTACT, DF232 LOW LOSS

SPECIFICATION CONTROL DRAWING

3. MECHANICAL

CAPTIVATION-CENTER CONTACT
 MAX AXIAL FORCE _____ 4.5 LBS.
 MAX RADIAL TORQUE _____ N/A
 CENTER CONTACT AXIAL FORCES
 ● INSERTION (MAX. OUNCES) _____ 32.0
 ● WITHDRAWAL (MIN. OUNCES) _____ 2.0
 CONNECTOR ENGAGEMENT/DISENGAGEMENT (MAX. LBS.) _____ 2.0
 CONNECTOR DURABILITY (MIN. CYCLES) _____ 500
 RECOMMENDED MATING TORQUE _____ 7 - 10 IN. LBS.
 RECOMMENDED MOUNTING TORQUE _____ 18 - 22 IN. LBS.

4. ENVIRONMENTAL

TEMPERATURE CYCLING _____ MIL-STD-202, METHOD 107, COND. C (-65° c TO + 125° c)
 SHOCK _____ MIL-STD-202, METHOD 213, COND. I (100 G's)
 VIBRATION _____ MIL-STD-202, METHOD 204, COND. D (20 G's)
 MOISTURE RESISTANCE _____ MIL-STD-202, METHOD 106, LESS STEP 7b
 CORROSION _____ MIL-STD-202, METHOD 101, COND. B (48 HOURS)
 BAROMETRIC PRESSURE (ALTITUDE) _____ MIL-STD-202, METHOD 105, COND. C (70,000 FT.) (190 VRMS)

5. MATERIAL

BODY, BUSHING, CLAMP NUT & HEX NUT _____ STAINLESS STEEL PER ASTM-A-582, TYPE 303, COND. A
 LOCKWASHER _____ 410 SERIES STAINLESS STEEL
 WASHER _____ 300 SERIES STAINLESS STEEL
 CONTACTS _____ BERYLLIUM COPPER PER ASTM-B-196/B, 196M-03, COPPER ALLOY No. UNS-C17300, TEMPER TD04.
 INSULATOR BEAD _____ PLASTIC COMPOSITE
 SOLDER SLEEVE _____ BRASS PER ASTM-B-16, TEMPER H02, ALLOY C36000.
 O-RINGS _____ SILICONE RUBBER PER ZZ-R-765.

6. FINISH

BODY, BUSHING, CLAMP NUT, LOCKWASHER, _____ PASSIVATE PER AMS-2700, TYPE 2, CLASS 4.
 HEX NUT & WASHER
 SOLDER SLEEVE _____ GOLD PER ASTM-B-488, TYPE I, CODE C, CLASS 1.27
 (.000050 MIN. THK.) OVER NICKEL per SAE AMS-QQ-N-290
 CLASS 1 (.000150 MIN. THK.) OVER COPPER PER AMS-2418
 (.000010 MIN. THK.)
 CONTACTS _____ GOLD PER ASTM-B-488, TYPE I, CODE C, CLASS 0.75
 (.000030 MIN. THK.) OVER NICKEL per SAE AMS-QQ-N-290
 (.000050 MIN. THK.) OVER COPPER per AMS-2418
 (.000010 MIN. THK.)
 INSULATOR & O-RINGS _____ N/A