

SPECIFICATION CONTROL DRAWING

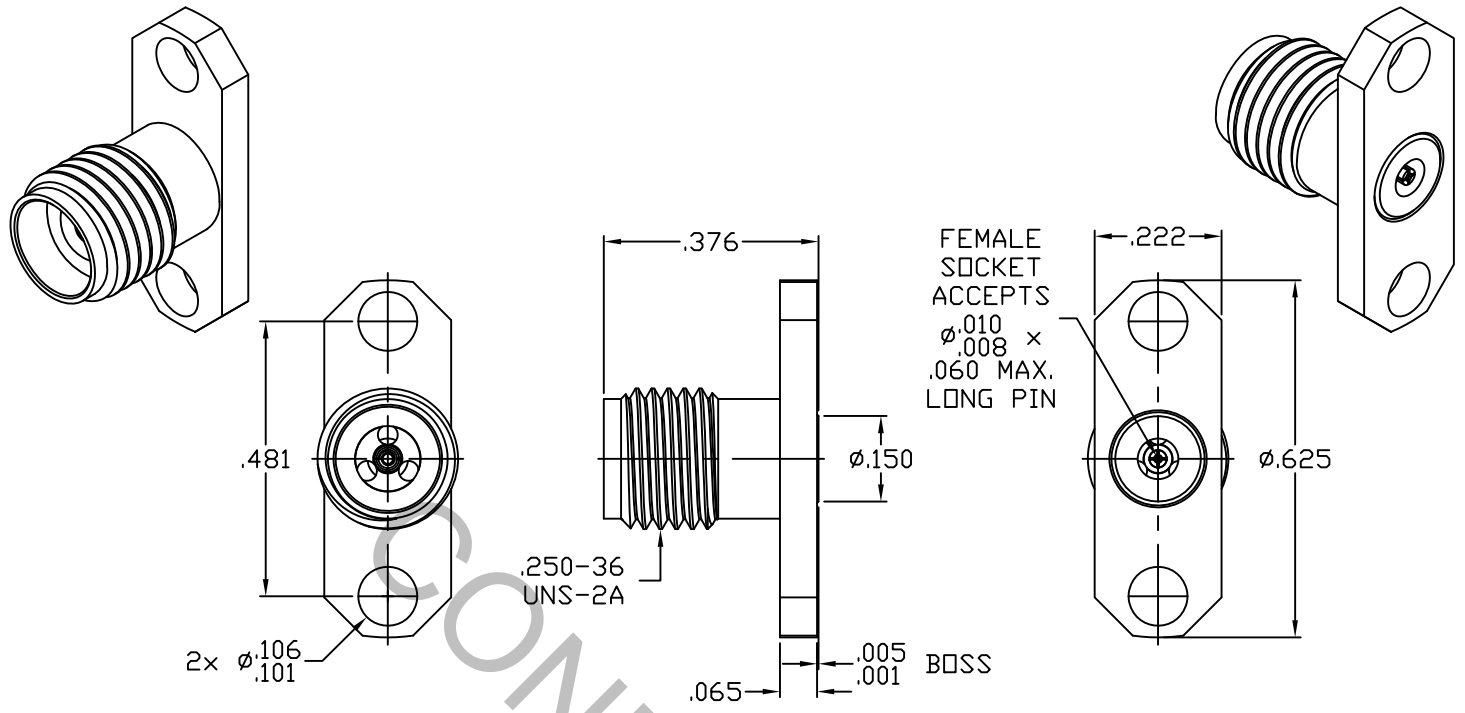

1. MATING INTERFACE DIMENSIONS Per MIL-STD-348 Fig. 323.2 (SMK JACK).

2. ELECTRICAL

FREQUENCY RANGE GHz	_____	DC TO 40.0 GHz
VSWR (MAX) *	_____	1.05 + .010 x FGHz
INSERTION LOSS (dB MAX) *	_____	.03 dB x $\sqrt{\text{FGHz}}$
NOMINAL IMPEDANCE (OHMS)	_____	50
VOLTAGE RATING (MAX. VRMS)	_____	250
RF LEAKAGE (MIN. dB DOWN)	_____	-100 dB - FGHz
TEMPERATURE RATING (DEGREES CENTIGRADE)	_____	-65°C TO + 125°C
DIELECTRIC WITHSTANDING VOLTAGE (MAX. VRMS)	_____	750
INSULATION RESISTANCE (MIN. MEGOHMS)	_____	5,000
CONTACT RESISTANCE		
• CENTER CONTACT (MAX. MILLIOHMS)	_____	6.0
• OUTER CONTACT (MAX. MILLIOHMS)	_____	2.0

* TERMINATED IN A 50 OHM LOAD

RoHS
COMPLIANT

This Document contains proprietary and confidential information.

REV.	DCN NO.	DATE	APP.	DIMENSIONS ARE IN INCHES TOLERANCES				INCORPORATED HAVERHILL, MA 01835		
				DECIMALS	FRACTIONAL	ANGULAR				
AA	03-1914	7/18/03	DC	.X ± .030 .XX ± .010 .XXX ± .005	± 1/64	X° ± 1'0" XX' ± 15'				
AB	08-1662	7/23/18	DC							
AC	18-2343	12/4/18	TS	DRAWN	GE	DATE	7/18/13	TITLE 2.92mm JACK, 2 HOLE FLANGE, FIELD REPLACEABLE		
				APPROVED	DC	DATE	7/18/13			
				CODE IDENT.		SHEET 1 OF 2				DWG. NO.
				2J899						

SPECIFICATION CONTROL DRAWING

3. MECHANICAL

CAPTIVATION-CENTER CONTACT

MIN. AXIAL FORCE _____ 4.5 LBS.

MIN. RADIAL TORQUE _____ N/A

CENTER CONTACT AXIAL FORCES

● INSERTION (MAX. OUNCES) _____ INTERFACE 32.0

● WITHDRAWAL (MIN. OUNCES) _____ INTERFACE 2.0

CONNECTOR ENGAGEMENT/DISENGAGEMENT (MAX. LBS.) _____ 2.0

CONNECTOR DURABILITY (MIN. CYCLES) _____ 500

RECOMMENDED MATING TORQUE _____ 7 - 10 IN. LBS.

4. ENVIRONMENTAL

TEMPERATURE CYCLING _____ MIL-STD-202, METHOD 107, COND. C (-65° c TO + 125° c)

SHOCK _____ MIL-STD-202, METHOD 213, COND. I (100 G's)

VIBRATION _____ MIL-STD-202, METHOD 204, COND. D (20 G's)

MOISTURE RESISTANCE _____ MIL-STD-202, METHOD 106, LESS STEP 7b

CORROSION _____ MIL-STD-202, METHOD 101, COND. B (48 HOURS)

BAROMETRIC PRESSURE (ALTITUDE) _____ MIL-STD-202, METHOD 105, COND. C (70,000 FT.) (190 VRMS)

5. MATERIAL

BODY & PRESS SLEEVE _____ STAINLESS STEEL PER ASTM-A-582, TYPE 303, COND. A

CONTACTS _____ BERYLLIUM COPPER PER ASTM-B-196/B, 196M-03, COPPER ALLOY No. UNS-C17300, TEMPER TD04.

INSULATOR _____ PLASTIC COMPOSITE

6. FINISH

BODY _____ PASSIVATE PER AMS-2700, TYPE 2, CLASS 4.

PRESS SLEEVE _____ GOLD PER ASTM-B-488, TYPE II, CODE C, CLASS 1.27 (.000050 MIN. THK.) OVER NICKEL PER SAE-AMS-QQ-N-290 CLASS 1 (.000150 MIN. THK.) OVER NICKEL, WOODS OR WATTS (.000010 MIN. THK.)

CONTACTS _____ GOLD PER ASTM-B-488, TYPE I, CODE C, CLASS 0.75 (.000030 MIN. THK.) OVER NICKEL PER SAE-AMS-QQ-N-290 CLASS 1 (.000050 MIN. THK.) OVER COPPER PER AMS-2418 (.000010 MIN. THK.)

INSULATOR _____ N/A