

SPECIFICATION CONTROL DRAWING

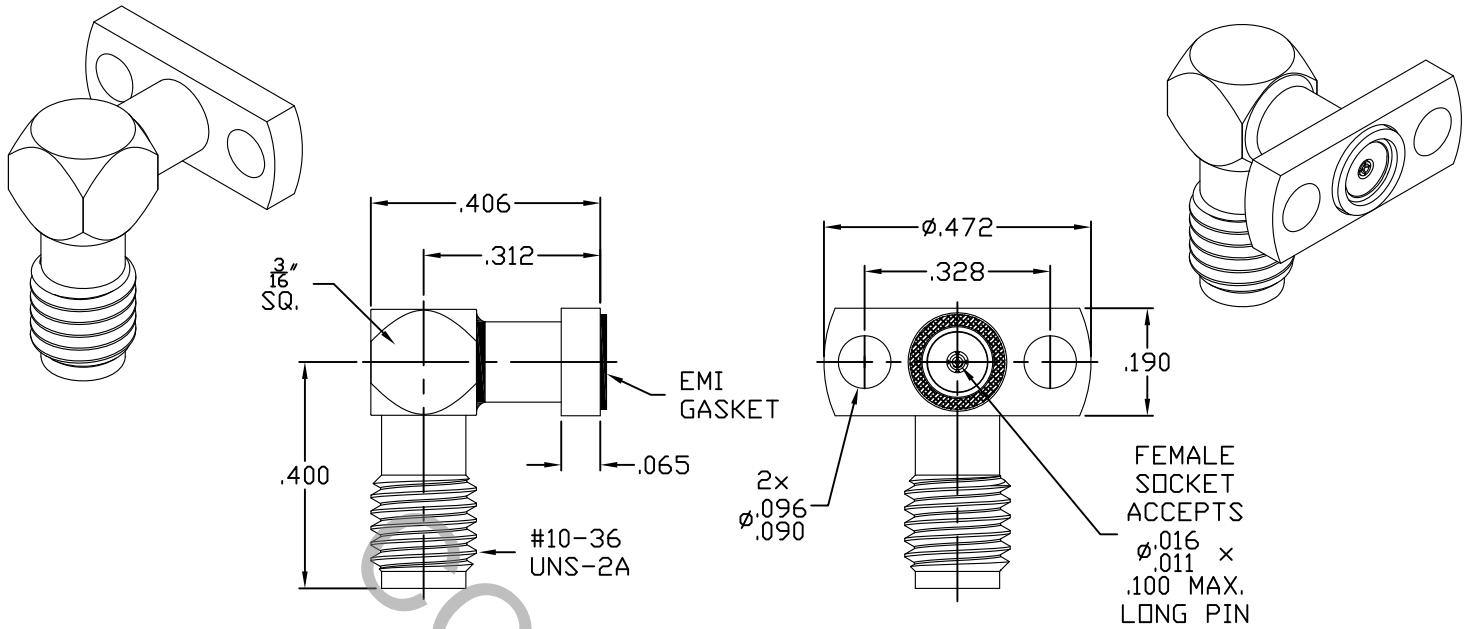

1. MATING

INTERFACE DIMENSIONS FOR SSMA, JACK PER MIL-STD-348 (Fig. 319-2).
 FLANGE INTERFACE INSPECTED 100% PER DYNAWAVE SPEC. 909-015
 VSWR & INSERTION LOSS DATA PROVIDED FOR ALL CONNECTORS.

2. ELECTRICAL

FREQUENCY RANGE GHz./VSWR	DC - 18.0 GHz. 1.20 + .007
	18.0 - 26.5 GHz. 1.35 + .009
	26.5 - 40.0 GHz. 1.50 + .010
INSERTION LOSS (dB MAX.) *	.080 dB x $\sqrt{\text{FGHz}}$.
NOMINAL IMPEDANCE (OHMS)	50
VOLTAGE RATING (MAX. VRMS)	250
RF LEAKAGE (MIN. dB DOWN)	-100 dB - FHGz.
TEMPERATURE RATING (DEGREES CENTIGRADE)	-55°C TO +165°C
DIELECTRIC WITHSTANDING VOLTAGE (MAX. VRMS)	750
INSULATION RESISTANCE (MIN. MEGOHMS)	5,000
CONTACT RESISTANCE	
• CENTER CONTACT (MAX. MILLIOHMS)	6.0
• OUTER CONTACT (MAX. MILLIOHMS)	2.0

* TERMINATED IN A 50 OHM LOAD

RoHS
COMPLIANT

This Document contains proprietary and confidential information.

REV.	DCN NO.	DATE	APP.	DIMENSIONS ARE IN INCHES TOLERANCES			 Haverhill MA 01835
				DECIMALS	FRACTIONAL	ANGULAR	
AA	07-1819	8/15/07	DC	.X ± .030 .XX ± .010 .XXX ± .005	± 1/64	X° ± 1'0" X° X' ± 15"	TITLE SSMA JACK, RIGHT ANGLE, 2 HOLE FLANGE FIELD REPLACEABLE DWG. NO. 9756-0781-6299
AB	08-1076	1/21/08	DC	SURFACE ROUGHNESS 63 √ MIL-STD 10.			
AC	12-1458	6/5/12	TS	DRAWN DC	DATE	8/15/07	
BA	13-1958	7/22/13	DC	APPROVED DC	DATE	8/15/07	
CA	13-2108	8/12/13	DC				
				CODE IDENT.	SHEET	1 OF 2	
				2J899			

SPECIFICATION CONTROL DRAWING

3. MECHANICAL

CAPTIVATION-CENTER CONTACT

- MAX AXIAL FORCE _____ 6.0 LBS.
- MAX RADIAL TORQUE _____ N/A

CENTER CONTACT AXIAL FORCES

- INSERTION (MAX OUNCES) _____ INTERFACE 32.0; REAR 32.0
- WITHDRAWAL (MIN. OUNCES) _____ INTERFACE 2.0, REAR 1.0

CONNECTOR ENGAGEMENT/DISENGAGEMENT (MAX. IN. LBS) — 2.0

CONNECTOR DURABILITY (MIN. CYCLES) _____ 500

RECOMMENDED MATING TORQUE _____ 5 - 8 IN. LBS.

4. ENVIRONMENTAL

TEMPERATURE CYCLING _____ MIL-STD-202, METHOD 102, COND. C (- 55°c TO + 165°c)

SHOCK _____ MIL-STD-202, METHOD 213, COND. I (100 G's)

VIBRATION _____ MIL-STD-202, METHOD 204, COND. D (20 G's)

MOISTURE RESISTANCE _____ MIL-STD-202, METHOD 106, LESS STEP 7b

CORROSION _____ MIL-STD-202, METHOD 101, COND. B (48 HOURS)

BAROMETRIC PRESSURE (ALTITUDE) _____ MIL-STD-202, METHOD 105, COND. C (70,000 FT.) (190 VRMS)

5. MATERIAL

CONNECTOR BODY & PRESS SLEEVE _____ STAINLESS STEEL PER ASTM-A-582, TYPE 303, COND. A.

CENTER CONTACT _____ BERYLLIUM COPPER PER ASTM-B-196/B, 196M-03, COPPER ALLOY No. UNS-C17300, TEMPER TD04.

INSULATOR _____ TEFLON PER ASTM-D-1710-02, TYPE 1, GRADE 1, CLASS B.

EMI GASKET _____ SILVER PLATED ALUMINUM IN SILICONE PER MIL-G-83528, TYPE B.

6. FINISH

CONNECTOR BODY _____ EX FLUX AND PICKLE (BRAZED PARTS), BUFF TO A BRIGHT APPEARANCE.

PRESS SLEEVE _____ PASSIVATE PER AMS-2700, TYPE 2, CLASS 4.

CENTER CONTACT _____ GOLD PER ASTM-B-488, TYPE I, CODE C, CLASS 1.27 (.000050 MIN. THK.) OVER NICKEL PER SAE-AMS-QQ-N-290 CLASS 1 (.000050 MIN. THK.) OVER COPPER PER AMS-2418 (.000010 MIN. THK.)

INSULATOR & EMI GASKET _____ N/A