

SPECIFICATION CONTROL DRAWING

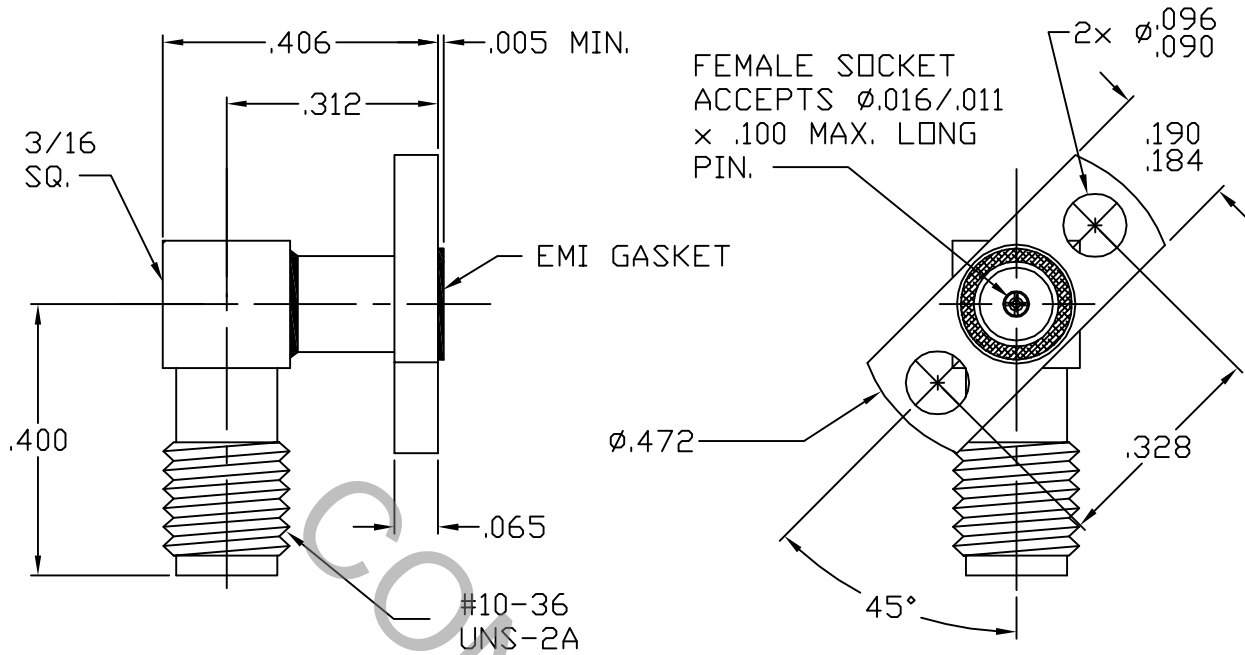

1. MATING INTERFACE DIMENSIONS PER MIL-STD-348 Fig. 319-2 (SSMA, JACK)

2. ELECTRICAL

FREQUENCY RANGE GHz./VSWR	DC - 18.0 GHz. 1.20 + .007
	18.0 - 26.5 GHz. 1.35 + .009
	26.5 - 40.0 GHz. 1.50 + .010
INSERTION LOSS (dB MAX) *	.080 dB x $\sqrt{\text{FGHz.}}$
NOMINAL IMPEDANCE (OHMS)	50
VOLTAGE RATING (MAX. VRMS)	250
RF LEAKAGE (MIN. dB DOWN)	-100 dB - FHGz.
TEMPERATURE RATING (DEGREES CENTIGRADE)	-65 ° c TO +165 ° c
DIELECTRIC WITHSTANDING VOLTAGE (MAX. VRMS)	750
INSULATION RESISTANCE (MIN. MEGOHMS)	5,000
CONTACT RESISTANCE	
• CENTER CONTACT (MAX. MILLIOHMS)	6.0
• OUTER CONTACT (MAX. MILLIOHMS)	2.0

* TERMINATED IN A 50 OHM LOAD

RoHS
COMPLIANT

REV.	DCN NO.	DATE	APP.	DIMENSIONS ARE IN INCHES TOLERANCES	 Haverhill MA 01835
AA	11-1819	9/13/11	TS	DECIMALS: .X ± .030 .XX ± .010 .XXX ± .005 FRACTIONAL: ± 1/64 ANGULAR: X° ± 1° 0' X° X' ± 15'	TITLE SSMA JACK, R/A, 2 HOLE FLANGE FIELD REPLACEABLE W/EMI GASKET
AB	12-1458	6/5/12	TS	SURFACE ROUGHNESS 63 $\sqrt{\text{MIL-STD 10.}}$	
				DRAWN TS DATE 9/13/11 APPROVED DC DATE 9/13/11	
				CODE IDENT. 2J899	DWG. NO. 9756-1781-6213
				SHEET 1 OF 2	

SPECIFICATION CONTROL DRAWING

3. MECHANICAL

CAPTIVATION-CENTER CONTACT

- MAX. AXIAL FORCE _____ 6.0 LBS.
- MAX. RADIAL TORQUE _____ 4.0 IN./OZ.

CENTER CONTACT AXIAL FORCES

- INSERTION (MAX. OUNCES) _____ INTERFACE 48.0; REAR 32.0
- WITHDRAWAL (MIN. OUNCES) _____ INTERFACE 2.0, REAR 1.0

CONNECTOR ENGAGEMENT/DISENGAGEMENT (MAX. IN. LBS) — 2.0

CONNECTOR DURABILITY (MIN. CYCLES) _____ 500

RECOMMENDED MATING TORQUE _____ 5 - 8 IN. LBS.

4. ENVIRONMENTAL

TEMPERATURE CYCLING _____ MIL-STD-202, METHOD 102, COND. C (-65 ° c TO + 200 ° c)

SHOCK _____ MIL-STD-202, METHOD 213, COND. I (100 G's)

VIBRATION _____ MIL-STD-202, METHOD 204, COND. D (20 G's)

MOISTURE RESISTANCE _____ MIL-STD-202, METHOD 106, LESS STEP 7b

CORROSION _____ MIL-STD-202, METHOD 101, COND. B (48 HOURS)

BAROMETRIC PRESSURE (ALTITUDE) _____ MIL-STD-202, METHOD 105, COND. C (70,000 FT.) (190 VRMS)

5. MATERIAL

CONNECTOR BODY _____ STAINLESS STEEL PER ASTM-A-582, TYPE 303, COND. A.

CENTER CONTACT _____ BERYLLIUM COPPER PER ASTM B196/B, 196M-03, COPPER ALLOY No. UNS C17300, TEMPER TD04.

INSULATOR _____ TEFLON PER ASTM-D-1710-02, TYPE 1, GRADE 1, CLASS B.

EMI GASKET _____ SILVER PLATED ALUMINUM IN SILICONE PER MIL-G-83528, TYPE B.

6. FINISH

CONNECTOR BODY _____ PASSIVATE PER AMS 2700, TYPE 2, CLASS 4.

CENTER CONTACT _____ GOLD PER ASTM-B-488, TYPE I, CODE C, CLASS 1.27 (.000050 MIN. THK.) OVER NICKEL PER SAE-AMS-QQ-N-290 CLASS 1 (.000050 MIN. THK.) OVER COPPER PER AMS-2418 (.000010 MIN. THK.)

INSULATOR AND EMI GASKET _____ N/A