

SPECIFICATION CONTROL DRAWING

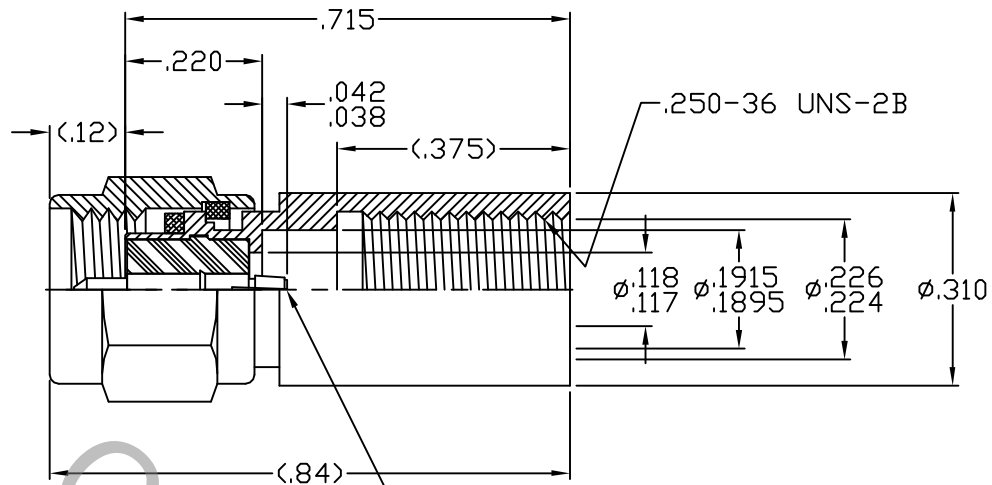

Ø.045/.044 FEMALE SOCKET ACCEPTS
Ø.0156 ±.0001 x .100 MAX. LONG PIN.

1. MATING INTERFACE DIMENSIONS FOR SMA PLUG per MIL-STD-348 (Fig. 310-1).

2. ELECTRICAL FOR ECLIPSE MICROWAVE ONLY

FREQUENCY RANGE GHz	_____	DC TO 18.0 GHz
VSWR (MAX.) *	_____	1.08 + .015 x FGHz
INSERTION LOSS (dB MAX.) *	_____	.04 dB x √FGHz
NOMINAL IMPEDANCE (OHMS)	_____	50
VOLTAGE RATING (MAX. VRMS)	_____	250
RF LEAKAGE (MIN. dB DOWN)	_____	100 dB - FGHz
TEMPERATURE RATING (DEGREES CENTIGRADE)	_____	-65°c TO + 150 °c
DIELECTRIC WITHSTANDING VOLTAGE (MAX. VRMS)	_____	1000
INSULATION RESISTANCE (MIN. MEGOHMS)	_____	5,000
CONTACT RESISTANCE		
• CENTER CONTACT (MAX. MILLIOHMS)	_____	3.0
• OUTER CONTACT (MAX. MILLIOHMS)	_____	2.0

*TERMINATED IN A 50 OHM LOAD

REV.	DCN NO.	DATE	APP.	DIMENSIONS ARE IN INCHES TOLERANCES			 HAVERHILL, MA 01835
AA	05-1091	1/25/05	DC	DECIMALS .X ±.030 .XX ±.010 .XXX ±.005	FRACTIONAL ±/64	ANGULAR X° ± 1 Ø' X° X' ± 15"	
				SURFACE ROUGHNESS 63 √MIL-STD-10.			
				DRAWN DC	DATE 1/25/05	TITLE SMA PLUG RF HOUSING ASSEMBLY	
				APPROVED TS	DATE 1/25/05		
				CODE IDENT. 2J899	SHEET 1 OF 2	DWG. NO.	9800-0682-6206

SPECIFICATION CONTROL DRAWING

3. MECHANICAL

CAPTIVATION-CENTER CONTACT

MAX.AXIAL FORCE _____ 6.0 LBS.

MAX. RADIAL TORQUE _____ 4.0 IN-OZ

CENTER CONTACT AXIAL FORCES

● INSERTION (MAX. OUNCES) _____ INTERFACE N/A / FLANGE END 32.0 OZ.

● WITHDRAWAL (MIN. OUNCES) _____ INTERFACE N/A / FLANGE END 2.0 OZ.

CONNECTOR ENGAGEMENT/DISENGAGEMENT (MAX. IN. LBS.) _____ 2.0

CONNECTOR DURABILITY (MIN. CYCLES) _____ 500

RECOMMENDED MATING TORQUE _____ 7 - 10 IN. LBS.

4. ENVIRONMENTAL

TEMPERATURE CYCLING _____ MIL-STD-202, METHOD 102, COND. C (-65 °c TO + 200 ℓ)

SHOCK _____ MIL-STD-202, METHOD 213, COND. I (100 G's)

VIBRATION _____ MIL-STD-202, METHOD 204, COND. D (20 G's)

MOISTURE RESISTANCE _____ MIL-STD-202, METHOD 106, LESS STEP 7b

CORROSION _____ MIL-STD-202, METHOD 101, COND. B (48 HOURS)

BAROMETRIC PRESSURE (ALTITUDE) _____ MIL-STD-202, METHOD 105, COND. C (70,000 FT.) (190 VRMS)

5. MATERIAL

BODY AND COUPLING NUT _____ STAINLESS STEEL PER ASTM A 581, TYPE 303, COND. A.

CONTACT AND RETAINING RING _____ BERYLLIUM COPPER PER ASTM B196-90, COPPER ALLOY No. UNS C17300, TEMPER TD04.

INSULATOR _____ TEFLON PER ASTM D 4894.

GASKET _____ SILICONE RUBBER PER ZZ-R-765, CLASS IIB, GRADE 50 OR 60.

6. FINISH

BODY AND COUPLING NUT _____ PASSIVATE PER QQ-P-35C, TYPE VI.

CONTACT _____ GOLD per ASTM B 488, TYPE II, GRADE C, CLASS 2 (.000100 Minimum Thickness) OVER NICKEL per QQ-N-290, CLASS 1 (.000100 Minimum Thickness) OVER COPPER per MIL-C-14550 (.000010 Minimum Thickness).

INSULATOR, GASKET AND RETAINING RING _____ N/A