

# SPECIFICATION CONTROL DRAWING

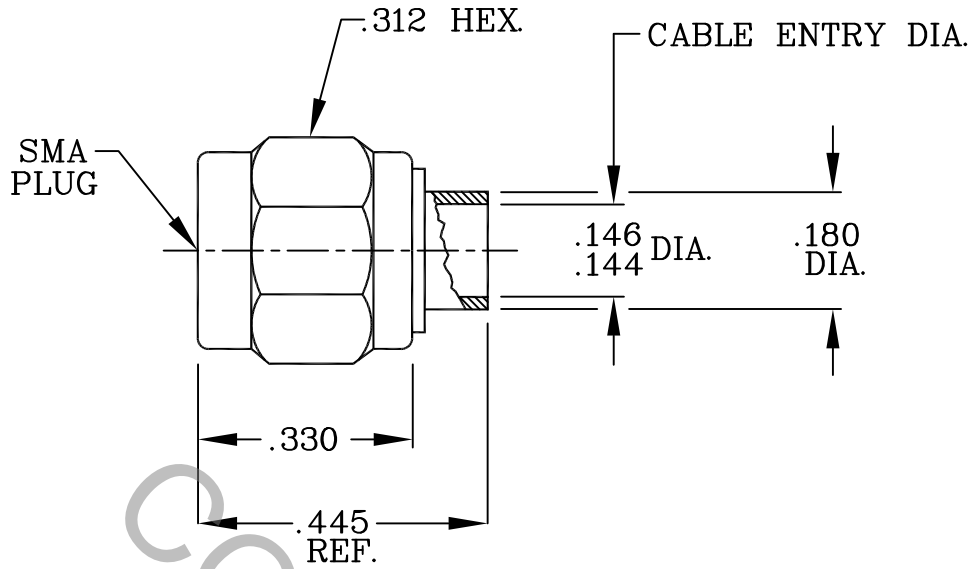

\* DESIGN FOR LOW INTERMOD

1. MATING INTERFACE DIMENSIONS FOR PLUG PER MIL-STD-348 (Fig. 310-1) AND DYNAWAVE MD-98.

2. ELECTRICAL

FREQUENCY RANGE GHz	DC TO 34.0 GHz.
VSWR (MAX) *	1.05 + .005 x FGHz.
INSERTION LOSS (dB MAX) *	.03 dB x $\sqrt{\text{FGHz}}$ .
NOMINAL IMPEDANCE (OHMS)	50
VOLTAGE RATING (MAX. VRMS)	335
RF LEAKAGE (MIN. dB DOWN)	-100 dB - FGHz.
TEMPERATURE RATING (DEGREES CENTIGRADE)	-65 ° c TO +165 ° c
DIELECTRIC WITHSTANDING VOLTAGE (MAX. VRMS)	1,500
INSULATION RESISTANCE (MIN. MEGOHMS)	10,000
CONTACT RESISTANCE	
• CENTER CONTACT (MAX. MILLIOHMS)	3.0
• OUTER CONTACT (MAX. MILLIOHMS)	2.0

\* TERMINATED IN A 50 OHM LOAD

**RoHS**  
COMPLIANT

REV.	DCN NO.	DATE	APP.	DIMENSIONS ARE IN INCHES TOLERANCES			 INCORPORATED HAVERHILL, MA 01835
AA	11-1242	3/16/11	TS	DECIMALS .X + .030 .XX ± .010 .XXX ± .005	FRACTIONAL ± 1/64	ANGULAR X ° ± 1 0' X ° X' ± 15'	
				SURFACE ROUGHNESS 63 $\sqrt{\text{MIL-STD 10}}$ .			TITLE SMA, PLUG TO .141 S.R. CABLE DIRECT SOLDER ATTACHMENT
				DRAWN	SS	DATE 3/16/11	
				APPROVED	TS	DATE 3/16/11	
				CODE IDENT. 2J899	SHEET 1 OF 2		DWG. NO. 9800-4120-2745

# SPECIFICATION CONTROL DRAWING

## 3. MECHANICAL

### CAPTIVATION-CENTER CONTACT

- MIN. AXIAL FORCE \_\_\_\_\_ N/A
- MIN. RADIAL TORQUE \_\_\_\_\_ N/A

### CENTER CONTACT AXIAL FORCES

- INSERTION (MAX. OUNCES) \_\_\_\_\_ N/A
- WITHDRAWAL (MIN. OUNCES) \_\_\_\_\_ N/A

CONNECTOR ENGAGEMENT/DISENGAGEMENT (MAX. IN. LBS.) \_\_\_\_\_ 2.0

CONNECTOR DURABILITY (MIN. CYCLES) \_\_\_\_\_ 1,000

RECOMMENDED MATING TORQUE \_\_\_\_\_ 7 - 10 IN. LBS.

## 4. ENVIRONMENTAL

TEMPERATURE CYCLING \_\_\_\_\_ MIL-STD-202, METHOD 102, COND. C ( -65 °c TO + 200°c )

SHOCK \_\_\_\_\_ MIL-STD-202, METHOD 213, COND. I (100 G's)

VIBRATION \_\_\_\_\_ MIL-STD-202, METHOD 204, COND. D (20 G's)

MOISTURE RESISTANCE \_\_\_\_\_ MIL-STD-202, METHOD 106, LESS STEP 7b

CORROSION \_\_\_\_\_ MIL-STD-202, METHOD 101, COND. B (48 HOURS)

BAROMETRIC PRESSURE (ALTITUDE) \_\_\_\_\_ MIL-STD-202, METHOD 105, COND. C ( 70,000 FT. ) ( 375 VRMS )

## 5. MATERIAL

BODY AND COUPLING NUT \_\_\_\_\_ STAINLESS STEEL PER ASTM-A-582, TYPE 303, COND. A

CENTER CONTACT AND RETAINING RING \_\_\_\_\_ BERYLLIUM COPPER PER ASTM-B-196/B, 196M-03, COPPER ALLOY No. UNS-C17300, TEMPER TD04.

INSULATOR \_\_\_\_\_ TEFLON PER ASTM-D-1710-02, TYPE 1, GRADE 1, CLASS B.

GASKET \_\_\_\_\_ SILICONE RUBBER PER ZZ-R-765.

## 6. FINISH

BODY \_\_\_\_\_ GOLD PER ASTM-B-488, TYPE I, CODE C, CLASS 1.25 (.000050 MIN. THK.) OVER NICKEL PER SAE-AMS-QQ-N-290 CLASS 1 (.000150 MIN. THK.) OVER NICKEL (WOODS OR WATTS) (.000010 MIN. THK.)

COUPLING NUT \_\_\_\_\_ PASSIVATE PER AMS-2700, TYPE 2, CLASS 4.

CENTER CONTACT \_\_\_\_\_ GOLD PER MIL-G-45204, TYPE II, GRADE C, CLASS 1 (.000050 MIN. THK.) OVER COPPER PER AMS-2418, CLASS 4, (.000100 MIN. THK.).

INSULATOR, RETAINING RING AND GASKET \_\_\_\_\_ N/A