

# SPECIFICATION CONTROL DRAWING

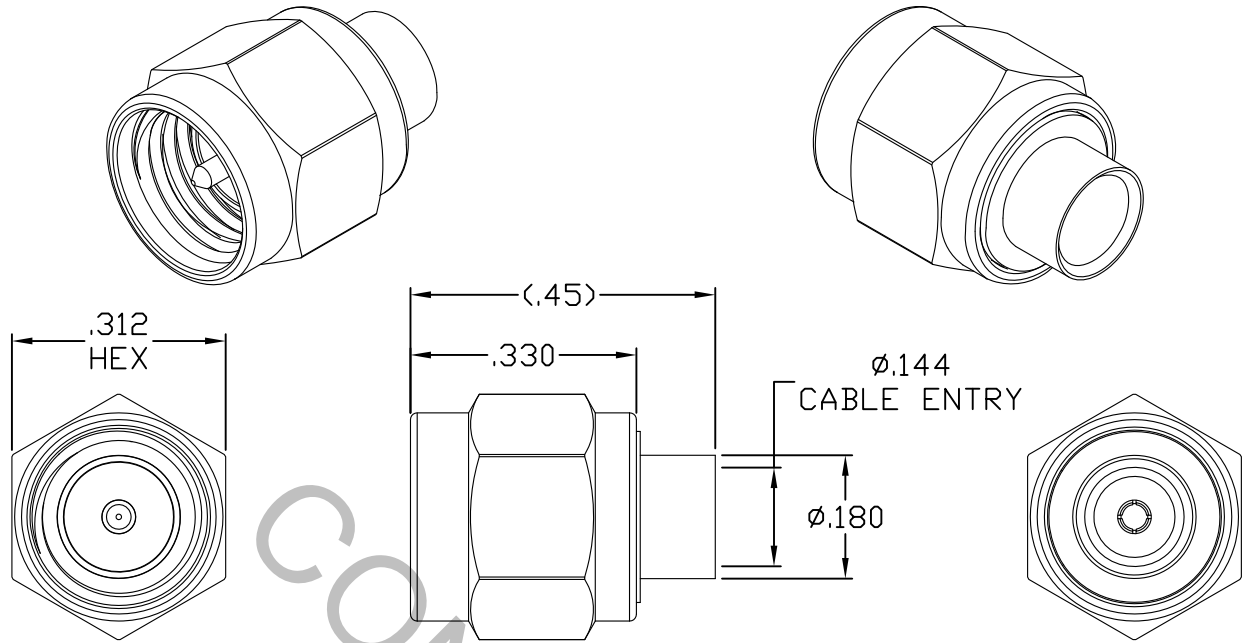

1. MATING INTERFACE DIMENSIONS PER MIL-STD-348 Fig. 310-1 (SMA, PLUG)

2. ELECTRICAL

FREQUENCY RANGE GHz	_____	DC TO 18.0 GHz.
VSWR (MAX) *	_____	1.06 + .006 x FGHz.
INSERTION LOSS (dB MAX) *	_____	.035 dB x $\sqrt{\text{FGHz}}$ .
NOMINAL IMPEDANCE (OHMS)	_____	50
VOLTAGE RATING (MAX. VRMS)	_____	250
RF LEAKAGE (MIN. dB DOWN)	_____	100 dB - FGHz.
TEMPERATURE RATING (DEGREES CENTIGRADE)	_____	-65 ° c TO +165 ° c
DIELECTRIC WITHSTANDING VOLTAGE (MAX. VRMS)	_____	750
INSULATION RESISTANCE (MIN. MEGOHMS)	_____	5,000
CONTACT RESISTANCE		
• CENTER CONTACT (MAX. MILLIOHMS)	_____	6.0
• OUTER CONTACT (MAX. MILLIOHMS)	_____	2.0

\* TERMINATED IN A 50 OHM LOAD

**RoHS**  
COMPLIANT

This Document contains proprietary and confidential information.

REV.	DCN NO.	DATE	APP.	DIMENSIONS ARE IN INCHES TOLERANCES			 HAVERHILL, MA. 01835
AA	05-1430	4/5/05	TS	DECIMALS	FRACTIONAL	ANGULAR	
AB	12-1681	8/15/12	DC	.X ± .030 .XX ± .010 .XXX ± .005	±/64	X° ± 1'0" X° X' ± 15"	
AC	16-2460	11/23/16	DC	SURFACE ROUGHNESS 63 √ MIL-STD 10.			
				DRAWN TS	DATE 4/5/05	TITLE SMA PLUG, STRAIGHT, DIRECT SOLDER ATTACHMENT, FOR RG-402 S/R CABLE CAPTURED CENTER CONTACT	
				APPROVED DC	DATE 4/5/05		
				CODE IDENT. 2J899	SHEET 1 OF 2		

# SPECIFICATION CONTROL DRAWING

## 3. MECHANICAL

### CAPTIVATION-CENTER CONTACT

- MIN. AXIAL FORCE \_\_\_\_\_ 4.0 LBS.
- MIN. RADIAL TORQUE \_\_\_\_\_ 4.0 IN.OZ.

### CENTER CONTACT AXIAL FORCES

- INSERTION (MAX. OUNCES) \_\_\_\_\_ N/A
- WITHDRAWAL (MIN. OUNCES) \_\_\_\_\_ N/A

CONNECTOR ENGAGEMENT/DISENGAGEMENT (MAX. IN. LBS.) \_\_\_\_\_ 2.0

CONNECTOR DURABILITY (MIN. CYCLES) \_\_\_\_\_ 1,000

RECOMMENDED MATING TORQUE \_\_\_\_\_ 7 - 10 IN. LBS.

## 4. ENVIRONMENTAL

TEMPERATURE CYCLING \_\_\_\_\_ MIL-STD-202, METHOD 102, COND. C ( -65 ° c TO + 165 ° c )

SHOCK \_\_\_\_\_ MIL-STD-202, METHOD 213, COND. I (100 G's)

VIBRATION \_\_\_\_\_ MIL-STD-202, METHOD 204, COND. D (20 G's)

MOISTURE RESISTANCE \_\_\_\_\_ MIL-STD-202, METHOD 106, LESS STEP 7b

CORROSION \_\_\_\_\_ MIL-STD-202, METHOD 101, COND. B (48 HOURS)

BAROMETRIC PRESSURE (ALTITUDE) \_\_\_\_\_ MIL-STD-202, METHOD 105, COND. C ( 70,000 FT. ) ( 190 VRMS )

## 5. MATERIAL

BODY AND COUPLING NUT \_\_\_\_\_ STAINLESS STEEL PER ASTM-A-582, TYPE 303, COND. A

CONTACT AND RETAINING RING \_\_\_\_\_ BERYLLIUM COPPER PER ASTM-B-196/B, 196M-03, COPPER ALLOY No. UNS-C17300, TEMPER TD04.

INSULATOR \_\_\_\_\_ TEFLON PER ASTM-D-1710-02, TYPE 1, GRADE 1, CLASS B.

GASKET \_\_\_\_\_ SILICONE RUBBER PER ZZ-R-765.

## 6. FINISH

BODY \_\_\_\_\_ GOLD PER ASTM-B-488, TYPE I, CODE C, CLASS 1.27 (.000050 MIN. THK.) OVER NICKEL PER SAE-AMS-QQ-N-290 CLASS 1 (.000150 MIN. THK.) OVER NICKEL (WOODS OR WATTS) (.000010 MIN. THK.)

COUPLING NUT \_\_\_\_\_ PASSIVATE PER AMS-2700, TYPE 2, CLASS 4.

CONTACT \_\_\_\_\_ GOLD PER ASTM-B-488, TYPE I, CODE C, CLASS 0.75 (.000030 - .000055 THK.) OVER NICKEL PER SAE-AMS-QQ-N-290 CLASS 1 (.000050 - .000075 THK.) OVER COPPER PER AMS-2418 (.000010 MIN. THK.)

INSULATOR, RETAINING RING AND GASKET \_\_\_\_\_ N/A