

# SPECIFICATION CONTROL DRAWING

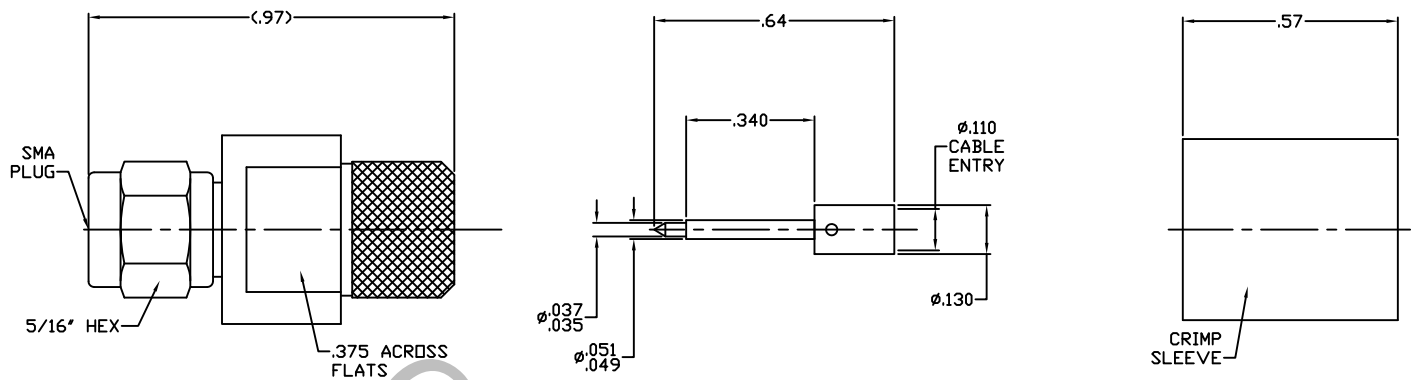

1. MATING INTERFACE DIMENSIONS per MIL-STD-348 Fig. 310.1 (SMA PLUG)

## 2. ELECTRICAL

FREQUENCY RANGE GHz	_____	DC TO 8.0 GHz.
VSWR (MAX.) *	_____	1.25 + .012 x FGHz.
INSERTION LOSS (dB MAX.) *	_____	.12 dB x $\sqrt{\text{FGHz}}$
NOMINAL IMPEDANCE (OHMS)	_____	50
VOLTAGE RATING (MAX. VRMS)	_____	335
RF LEAKAGE (MIN. dB DOWN)	_____	-100 dB - FGHz.
TEMPERATURE RATING (DEGREES CENTIGRADE)	_____	-65 ° c TO + 165 ° c
DIELECTRIC WITHSTANDING VOLTAGE (MAX. VRMS)	_____	1,000
INSULATION RESISTANCE (MIN. MEGOHMS)	_____	10,000
CONTACT RESISTANCE		
• CENTER CONTACT (MAX. MILLIOHMS)	_____	4.0
• OUTER CONTACT (MAX. MILLIOHMS)	_____	2.0

\*TERMINATED IN A 50 OHM LOAD

**RoHS**  
COMPLIANT

REV.	DCN NO.	DATE	APP.	DIMENSIONS ARE IN INCHES TOLERANCES			 HAVERHILL, MA. 01835
AA	09-1747	9/29/08	TS	DECIMALS	FRACTIONAL	ANGULAR	
				.X ± .030 .XX ± .010 .XXX ± .005	± 1/64	X ° ± 1'0" X ° X' ± 15'	TITLE SMA, PLUG STRAIGHT, CRIMP ATTACHMENT TO LMR 400 CABLE
				DRAWN	TS	DATE 9/28/09	
				APPROVED	DC	DATE 9/28/09	
				CODE IDENT. 2J899	SHEET 1 OF 2		DWG. NO. 9800-4230-3200

# SPECIFICATION CONTROL DRAWING

## 3. MECHANICAL

### CAPTIVATION-CENTER CONTACT

MAX. AXIAL FORCE \_\_\_\_\_ N/A

MAX. RADIAL TORQUE \_\_\_\_\_ N/A

### CENTER CONTACT AXIAL FORCES

● INSERTION (MAX. OUNCES) \_\_\_\_\_ N/A

● WITHDRAWAL (MIN. OUNCES) \_\_\_\_\_ N/A

CONNECTOR ENGAGEMENT/DISENGAGEMENT (MAX. LBS.) \_\_\_\_\_ 2.0

CONNECTOR DURABILITY (MIN. CYCLES) \_\_\_\_\_ 500

RECOMMENDED MATING TORQUE \_\_\_\_\_ 7 - 10 IN. LBS.

## 4. ENVIRONMENTAL

TEMPERATURE CYCLING \_\_\_\_\_ MIL-STD-202, METHOD 102, COND. C ( -65 °c TO + 165° c )

SHOCK \_\_\_\_\_ MIL-STD-202, METHOD 213, COND. I (100 G's)

VIBRATION \_\_\_\_\_ MIL-STD-202, METHOD 204, COND. D (20 G's)

MOISTURE RESISTANCE \_\_\_\_\_ MIL-STD-202, METHOD 106, LESS STEP 7b

CORROSION \_\_\_\_\_ MIL-STD-202, METHOD 101, COND. B (48 HOURS)

BAROMETRIC PRESSURE (ALTITUDE) \_\_\_\_\_ MIL-STD-202, METHOD 105, COND. C ( 70,000 FT. ) ( 190 VRMS )

## 5. MATERIAL

BODY AND COUPLING NUT \_\_\_\_\_ STAINLESS STEEL PER ASTM A 582, TYPE 303, COND. A.

CRIMP SLEEVE \_\_\_\_\_ BRASS PER ASTM B 16, TEMPER H02, ALLOY C36000.

CONTACT & RETAINING RING \_\_\_\_\_ BERYLLIUM COPPER PER ASTM B 196/B 196M-03, COPPER ALLOY UNS C 17300, TEMPER TD04

INSULATOR \_\_\_\_\_ TEFLON PER ASTM D 1710-02, TYPE 1, GRADE 1, CLASS B

GASKET \_\_\_\_\_ SILICONE RUBBER PER ZZ-R-765

## 6. FINISH

BODY & COUPLING NUT \_\_\_\_\_ PASSIVATE PER AMS QQ-P-35, TYPE 2

CRIMP SLEEVE \_\_\_\_\_ NICKEL PER QQ-N-290, CLASS 1 (.00050 MIN. THK. OVER COPPER PER MIL-C-14550, (.000010 MIN. THK.).

CONTACT \_\_\_\_\_ GOLD PER ASTM B 488, TYPE I, CODE C, CLASS 2.5 (.000100 Min. Thk.) OVER NICKEL PER QQ-N-290 (.000050 Min. Thk.) OVER COPPER PER MIL-C-14550 (.000010 Min. Thk.).

INSULATOR, RETAINING RING & GASKET \_\_\_\_\_ N/A