

SPECIFICATION CONTROL DRAWING

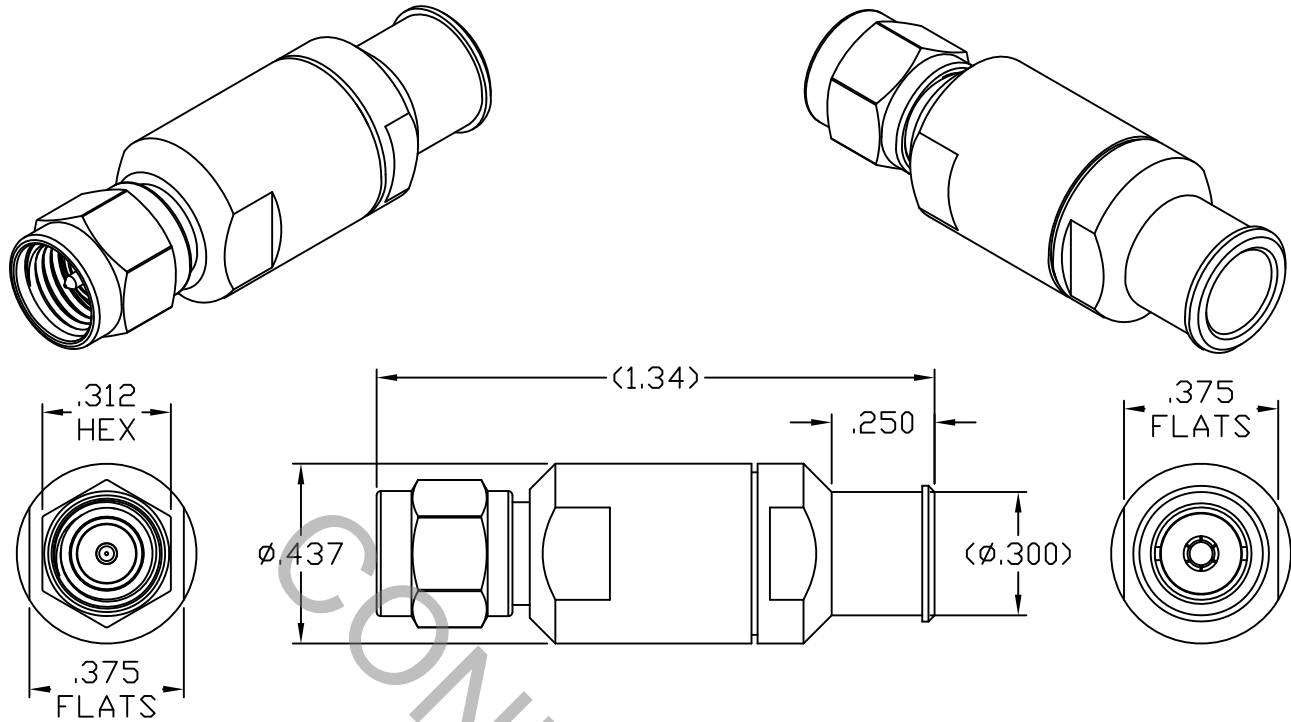

1. MATING INTERFACE DIMENSIONS Per MIL-STD-348 Fig. 310.1 (SMA PLUG).

2. ELECTRICAL

FREQUENCY RANGE GHz	_____	DC TO 26.5 GHz
VSWR (MAX.) *	_____	1.05 + .005 x FGHz
INSERTION LOSS (dB MAX.) *	_____	.04 dB x $\sqrt{\text{FGHz}}$
NOMINAL IMPEDANCE (OHMS)	_____	50
VOLTAGE RATING (MAX. VRMS)	_____	333
RF LEAKAGE (MIN. dB DOWN)	_____	-100 dB - FGHz
TEMPERATURE RATING (DEGREES CENTIGRADE)	_____	-65°C TO + 165°C
DIELECTRIC WITHSTANDING VOLTAGE (MAX. VRMS)	_____	1,000
INSULATION RESISTANCE (MIN. MEGOHMS)	_____	5,000
CONTACT RESISTANCE		
• CENTER CONTACT (MAX. MILLIOHMS)	_____	6.0
• OUTER CONTACT (MAX. MILLIOHMS)	_____	2.0

* TERMINATED IN A 50 OHM LOAD

RoHS
COMPLIANT

This Document contains proprietary and confidential information.

REV.	DCN NO.	DATE	APP.	DIMENSIONS ARE IN INCHES TOLERANCES			 Haverhill, MA 01835
				DECIMALS	FRACTIONAL	ANGULAR	
AA	12-1912	10/8/12	DC	.X ± .030		X ° ± 1° 0'	TITLE SMA PLUG, SOLDER CLAMP, PLUG-IN CONTACT, T7-00030 LOW LOSS
AB	13-2019	7/23/13	DC	.XX ± .010	± 1/64	X ° X' ± 15'	
				DRAWN	DC	DATE	10/8/12
				APPROVED	DC	DATE	10/8/12
				CODE IDENT.	SHEET 1 OF 2		DWG. NO.
				6DZL5			9800-7030-6240

SPECIFICATION CONTROL DRAWING

3. MECHANICAL

CAPTIVATION-CENTER CONTACT

MAX AXIAL FORCE _____ 4.5 LBS.

MAX RADIAL TORQUE _____ N/A

CENTER CONTACT AXIAL FORCES

● INSERTION (MAX. OUNCES) _____ N/A

● WITHDRAWAL (MIN. OUNCES) _____ N/A

CONNECTOR ENGAGEMENT/DISENGAGEMENT (MAX. LBS.) _____ 2.0

CONNECTOR DURABILITY (MIN. CYCLES) _____ 500

RECOMMENDED MATING TORQUE _____ 7 - 10 IN. LBS.

4. ENVIRONMENTAL

TEMPERATURE CYCLING _____ MIL-STD-202, METHOD 107, COND. C (-65° c TO + 165° c)

SHOCK _____ MIL-STD-202, METHOD 213, COND. I (100 G's)

VIBRATION _____ MIL-STD-202, METHOD 204, COND. D (20 G's)

MOISTURE RESISTANCE _____ MIL-STD-202, METHOD 106, LESS STEP 7b

CORROSION _____ MIL-STD-202, METHOD 101, COND. B (48 HOURS)

BAROMETRIC PRESSURE (ALTITUDE) _____ MIL-STD-202, METHOD 105, COND. C (70,000 FT.) (250 VRMS)

5. MATERIAL

BODY, PRESS SLEEVE, COUPLING NUT & CLAMP NUT _____ STAINLESS STEEL PER ASTM-A-582, TYPE 303, COND. A
CONTACTS & RETAINING RING _____ BERYLLIUM COPPER PER ASTM-B-196/B, 196M-03, COPPER
ALLOY No. UNS-C17300, TEMPER TD04.

INTERFACE INSULATOR _____ TEFLON PER ASTM-D-1710-02, TYPE 1, GRADE 1, CLASS B.

GASKET & O-RING _____ SILICONE RUBBER PER ZZ-R-765.

SUPPORT INSULATOR _____ CROSS LINKED POLYETHYLENE (400° F).

SOLDER SLEEVE _____ BRASS PER ASTM-B-16, TEMPER H02, ALLOY C36000.

6. FINISH

BODY, BUSHING, COUPLING NUT & CLAMP NUT _____ PASSIVATE PER AMS-2700, TYPE 2, CLASS 4.

SOLDER SLEEVE _____ GOLD PER ASTM-B-488, TYPE I, CODE C, CLASS 1.27
(.000050 MIN. THK.) OVER NICKEL PER SAE-AMS-QQ-N-290
CLASS 1 (.000150 MIN. THK.) OVER COPPER PER AMS-2418
(.000010 MIN. THK.)

CONTACTS _____ GOLD PER ASTM-B-488, TYPE I, CODE C, CLASS 0.75
(.000030 MIN. THK.) OVER NICKEL PER SAE-AMS-QQ-N-290
CLASS 1 (.000050 MIN. THK.) OVER COPPER PER AMS-2418
(.000010 MIN. THK.)

INSULATORS, RETAINING RING, GASKET & O-RING _____ N/A