

# SPECIFICATION CONTROL DRAWING

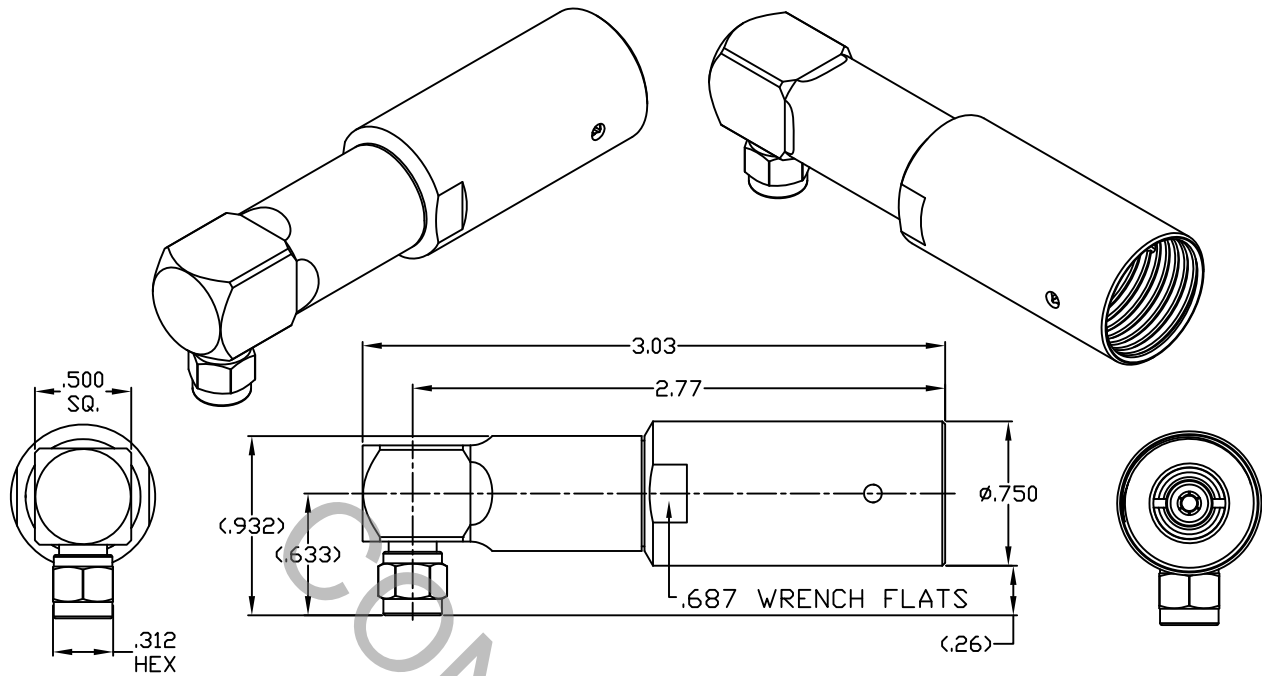

SOLD ON DYNAWAVE CABLE ASSEMBLIES ONLY

1. MATING INTERFACE DIMENSIONS Per MIL-STD-348 Fig. 310.1 (SMA PLUG).

2. ELECTRICAL

FREQUENCY RANGE GHz	_____	DC TO 18.0 GHz
VSWR (MAX) *	_____	1.05 + .006 x FGHz
INSERTION LOSS (dB MAX) *	_____	.05 dB x √FGHz
NOMINAL IMPEDANCE (OHMS)	_____	50
VOLTAGE RATING (MAX. VRMS)	_____	333
RF LEAKAGE (MIN. dB DOWN)	_____	-100 dB - FGHz
TEMPERATURE RATING (DEGREES CENTIGRADE)	_____	-65°c TO + 165°c
DIELECTRIC WITHSTANDING VOLTAGE (MAX. VRMS)	_____	1,000
INSULATION RESISTANCE (MIN. MEGOHMS)	_____	5,000
CONTACT RESISTANCE		
• CENTER CONTACT (MAX. MILLIOHMS)	_____	6.0
• OUTER CONTACT (MAX. MILLIOHMS)	_____	2.0

\* TERMINATED IN A 50 OHM LOAD

**RoHS**  
COMPLIANT

REV.	DCN NO.	DATE	APP.	DIMENSIONS ARE IN INCHES TOLERANCES			CABLE INCORPORATED HAVERHILL, MA 01835
AA	13-1329	3/7/13	DC	DECIMALS	FRACTIONAL	ANGULAR	
				.X ± .030		X ° ± 1° 0'	
				.XX ± .010	± 1/64	X ° X' ± 15'	
				.XXX ± .005			
				DRAWN	RMS	DATE	3/7/13
				APPROVED	DC	DATE	3/7/13
				CODE IDENT.		SHEET	1 OF 2
				6DZL5		DWG. NO.	9801-118A-6240
						TITLE SMA PLUG, RIGHT ANGLE, SOLDER CLAMP, PLUG-IN CONTACT, DF118 ARMORED	

# SPECIFICATION CONTROL DRAWING

## 3. MECHANICAL

CAPTIVATION-CENTER CONTACT  
     MAX AXIAL FORCE \_\_\_\_\_ 4.5 LBS.  
     MAX RADIAL TORQUE \_\_\_\_\_ 4.0 OZS.  
 CENTER CONTACT AXIAL FORCES  
     ● INSERTION (MAX OUNCES) \_\_\_\_\_ N/A  
     ● WITHDRAWAL (MIN. OUNCES) \_\_\_\_\_ N/A  
 CONNECTOR ENGAGEMENT/DISENGAGEMENT (MAX. LBS.) \_\_\_\_\_ 2.0  
 CONNECTOR DURABILITY (MIN. CYCLES) \_\_\_\_\_ 500  
 RECOMMENDED MATING TORQUE \_\_\_\_\_ 7 - 10 IN. LBS.

## 4. ENVIRONMENTAL

TEMPERATURE CYCLING \_\_\_\_\_ MIL-STD-202, METHOD 107, COND. C ( -65° c TO + 165° c )  
 SHOCK \_\_\_\_\_ MIL-STD-202, METHOD 213, COND. I (100 G's)  
 VIBRATION \_\_\_\_\_ MIL-STD-202, METHOD 204, COND. D (20 G's)  
 MOISTURE RESISTANCE \_\_\_\_\_ MIL-STD-202, METHOD 106, LESS STEP 7b  
 CORROSION \_\_\_\_\_ MIL-STD-202, METHOD 101, COND. B (48 HOURS)  
 BAROMETRIC PRESSURE (ALTITUDE) \_\_\_\_\_ MIL-STD-202, METHOD 105, COND. C ( 70,000 FT. ) ( 250 VRMS )

## 5. MATERIAL

BODY, BUSHING, COUPLING NUT, CLAMP NUT, CUBE & PRESS SLEEVE \_\_\_\_\_ STAINLESS STEEL PER ASTM-A-582, TYPE 303, COND. A  
 CONTACTS & RETAINING RING \_\_\_\_\_ BERYLLIUM COPPER PER ASTM-B-196/B, 196M-03, COPPER ALLOY No. UNS-C17300, TEMPER TD04.  
 INSULATORS \_\_\_\_\_ TEFLON PER ASTM-D-1710-02, TYPE 1, GRADE 1, CLASS B.  
 INSULATOR BEAD \_\_\_\_\_ CROSS LINKED POLYETHYLENE (400° F)  
 GASKET & O-RING \_\_\_\_\_ SILICONE RUBBER PER ZZ-R-765.  
 SOLDER SLEEVE \_\_\_\_\_ BRASS PER ASTM-B-16, TEMPER H02, ALLOY C36000.

## 6. FINISH

BODY, BUSHING, COUPLING NUT, CLAMP NUT, CUBE & PRESS SLEEVE \_\_\_\_\_ PASSIVATE PER AMS-2700, TYPE 2, CLASS 4.  
 SOLDER SLEEVE \_\_\_\_\_ GOLD PER ASTM-B-488, TYPE I, CODE C, CLASS 1.27 (.000050 MIN. THK.) OVER NICKEL PER SAE-AMS-QQ-N-290 CLASS 1 (.000150 MIN. THK.) OVER COPPER PER AMS-2418 (.000010 MIN. THK.)  
 INTERFACE CONTACT \_\_\_\_\_ GOLD PER ASTM-B-488, TYPE I, CODE C, CLASS 1.27 (.000050 MIN. THK.) OVER NICKEL PER SAE-AMS-QQ-N-290 CLASS 1 (.000050 MIN. THK.) OVER COPPER PER AMS-2418 (.000010 MIN. THK.)  
 INTERNAL CONTACTS \_\_\_\_\_ GOLD PER ASTM-B-488, TYPE I, CODE C, CLASS 0.75 (.000030 MIN. THK.) OVER NICKEL PER SAE-AMS-QQ-N-290 CLASS 1 (.000050 MIN. THK.) OVER COPPER PER AMS-2418 (.000010 MIN. THK.)  
 INSULATORS, RETAINING RING, GASKET & O-RING \_\_\_\_\_ N/A