

SPECIFICATION CONTROL DRAWING

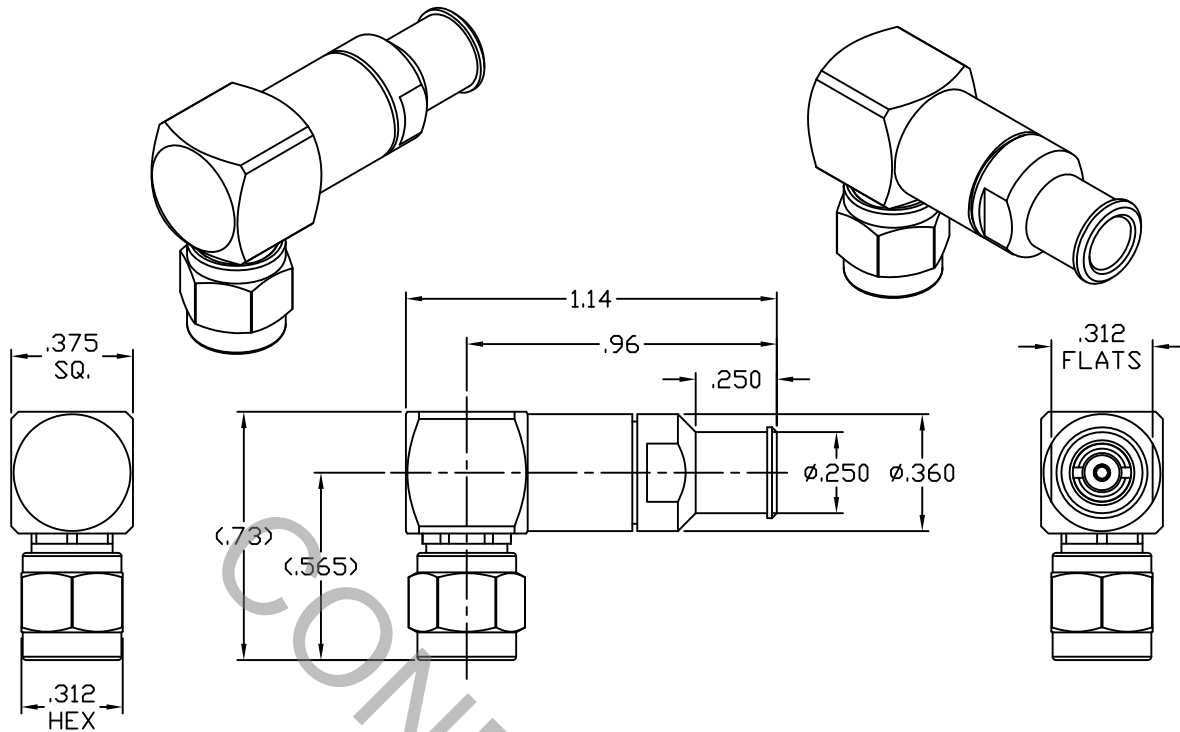

1. MATING INTERFACE DIMENSIONS Per MIL-STD-348 Fig. 310.1 (SMA PLUG).

2. ELECTRICAL

FREQUENCY RANGE GHz	_____	DC TO 18.0 GHz
VSWR (MAX) *	_____	1.05 + .006 x FGHz
INSERTION LOSS (dB MAX) *	_____	.05 dB x √FGHz
NOMINAL IMPEDANCE (OHMS)	_____	50
VOLTAGE RATING (MAX. VRMS)	_____	333
RF LEAKAGE (MIN. dB DOWN)	_____	-100 dB - FGHz
TEMPERATURE RATING (DEGREES CENTIGRADE)	_____	-65°c TO + 165°c
DIELECTRIC WITHSTANDING VOLTAGE (MAX. VRMS)	_____	1,000
INSULATION RESISTANCE (MIN. MEGOHMS)	_____	5,000
CONTACT RESISTANCE		
• CENTER CONTACT (MAX. MILLIOHMS)	_____	6.0
• OUTER CONTACT (MAX. MILLIOHMS)	_____	2.0

* TERMINATED IN A 50 OHM LOAD

RoHS
COMPLIANT

REV.	DCN NO.	DATE	APP.	DIMENSIONS ARE IN INCHES TOLERANCES			CABLE INCORPORATED HAVERHILL, MA 01835
AA	13-1298	3/2/13	DC	DECIMALS	FRACTIONAL	ANGULAR	
				.X ± .030		X ° ± 1° 0'	TITLE SMA PLUG, RIGHT ANGLE, SOLDER CLAMP, PLUG-IN CONTACT, DF140 CABLE
				.XX ± .010	± 1/64	X ° X' ± 15'	
				.XXX ± .005			
				DRAWN	RMS	DATE	3/2/13
				APPROVED	DC	DATE	3/2/13
				CODE IDENT.	SHEET 1 OF 2		DWG. NO.
				6DZL5			9801-140H-6240

SPECIFICATION CONTROL DRAWING

3. MECHANICAL

CAPTIVATION-CENTER CONTACT
 MAX AXIAL FORCE _____ 4.5 LBS.
 MAX RADIAL TORQUE _____ 4.0 OZS.
 CENTER CONTACT AXIAL FORCES
 ● INSERTION (MAX. OUNCES) _____ N/A
 ● WITHDRAWAL (MIN. OUNCES) _____ N/A
 CONNECTOR ENGAGEMENT/DISENGAGEMENT (MAX. LBS.) _____ 2.0
 CONNECTOR DURABILITY (MIN. CYCLES) _____ 500
 RECOMMENDED MATING TORQUE _____ 7 - 10 IN. LBS.

4. ENVIRONMENTAL

TEMPERATURE CYCLING _____ MIL-STD-202, METHOD 107, COND. C (-65° c TO + 165° c)
 SHOCK _____ MIL-STD-202, METHOD 213, COND. I (100 G's)
 VIBRATION _____ MIL-STD-202, METHOD 204, COND. D (20 G's)
 MOISTURE RESISTANCE _____ MIL-STD-202, METHOD 106, LESS STEP 7b
 CORROSION _____ MIL-STD-202, METHOD 101, COND. B (48 HOURS)
 BAROMETRIC PRESSURE (ALTITUDE) _____ MIL-STD-202, METHOD 105, COND. C (70,000 FT.) (250 VRMS)

5. MATERIAL

BODY, CUBE, COUPLING NUT, CLAMP NUT & _____ STAINLESS STEEL PER ASTM-A-582, TYPE 303, COND. A
 PRESS SLEEVE
 CONTACT & RETAINING RING _____ BERYLLIUM COPPER PER ASTM-B-196/B, 196M-03, COPPER
 ALLOY No. UNS-C17300, TEMPER TD04.
 INSULATORS _____ TEFLON PER ASTM-D-1710-02, TYPE 1, GRADE 1, CLASS B.
 GASKET & O-RING _____ SILICONE RUBBER PER ZZ-R-765.
 SOLDER SLEEVE _____ BRASS PER ASTM-B-16, TEMPER H02, ALLOY C36000.

6. FINISH

BODY, CUBE, COUPLING NUT, CLAMP NUT & _____ PASSIVATE PER AMS-2700, TYPE 2, CLASS 4.
 PRESS SLEEVE
 SOLDER SLEEVE _____ GOLD PER ASTM-B-488, TYPE I, CODE C, CLASS 1.27
 (.000050 MIN. THK.) OVER NICKEL PER SAE-AMS-QQ-N-290
 CLASS 1 (.000150 MIN. THK.) OVER COPPER PER AMS-2418.
 (.000010 MIN. THK.)
 CONTACT _____ GOLD PER ASTM-B-488, TYPE I, CODE C, CLASS 0.75
 (.000030 MIN. THK.) OVER NICKEL PER SAE-AMS-QQ-N-290
 CLASS 1 (.000050 MIN. THK.) OVER COPPER PER AMS-2418
 (.000010 MIN. THK.)
 INSULATORS, RETAINING RING, GASKET & O-RING _____ N/A