

# SPECIFICATION CONTROL DRAWING

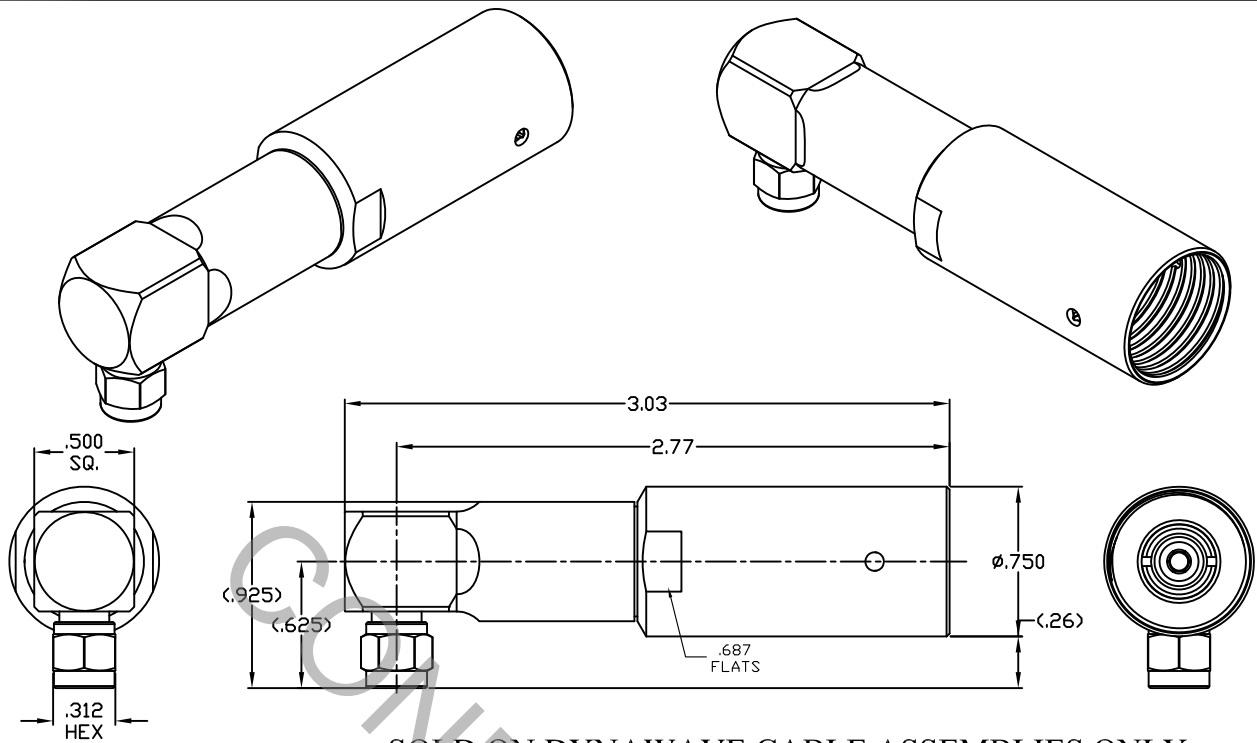

SOLD ON DYNAWAVE CABLE ASSEMBLIES ONLY

1. MATING INTERFACE DIMENSIONS Per MIL-STD-348 Fig. 310.1 (SMA PLUG).

## 2. ELECTRICAL

FREQUENCY RANGE GHz	_____	DC TO 18.0 GHz
VSWR (MAX) *	_____	1.05 + .006 x FGHz
INSERTION LOSS (dB MAX) *	_____	.05 dB x √FGHz
NOMINAL IMPEDANCE (OHMS)	_____	50
VOLTAGE RATING (MAX. VRMS)	_____	333
RF LEAKAGE (MIN. dB DOWN)	_____	-100 dB - FGHz
TEMPERATURE RATING (DEGREES CENTIGRADE)	_____	-65°c TO + 165°c
DIELECTRIC WITHSTANDING VOLTAGE (MAX. VRMS)	_____	1,000
INSULATION RESISTANCE (MIN. MEGOHMS)	_____	5,000
CONTACT RESISTANCE		
• CENTER CONTACT (MAX. MILLIOHMS)	_____	6.0
• OUTER CONTACT (MAX. MILLIOHMS)	_____	2.0

\* TERMINATED IN A 50 OHM LOAD

**RoHS**  
COMPLIANT

REV.	DCN NO.	DATE	APP.	DIMENSIONS ARE IN INCHES TOLERANCES			CABLE INCORPORATED HAVERHILL, MA 01835
AA	12-2233	12/11/12	DC	DECIMALS .X ± .030 .XX ± .010 .XXX ± .005	FRACTIONAL ± 1/64	ANGULAR X ° ± 1° 0' X ° X' ± 15'	
				DRAWN	RMS	DATE 12/10/12	TITLE SMA PLUG, RIGHT ANGLE, SOLDER CLAMP, PLUG-IN CTC, DF218 ARMORED
				APPROVED	DC	DATE 12/11/12	
				CODE IDENT. 6DZL5	SHEET 1 OF 2		DWG. NO. 9801-218A-6240

# SPECIFICATION CONTROL DRAWING

## 3. MECHANICAL

CAPTIVATION-CENTER CONTACT  
 MAX AXIAL FORCE \_\_\_\_\_ 4.5 LBS.  
 MAX RADIAL TORQUE \_\_\_\_\_ 4.0 OZS.  
 CENTER CONTACT AXIAL FORCES  
 ● INSERTION (MAX. OUNCES) \_\_\_\_\_ N/A  
 ● WITHDRAWAL (MIN. OUNCES) \_\_\_\_\_ N/A  
 CONNECTOR ENGAGEMENT/DISENGAGEMENT (MAX. LBS.) \_\_\_\_\_ 2.0  
 CONNECTOR DURABILITY (MIN. CYCLES) \_\_\_\_\_ 500  
 RECOMMENDED MATING TORQUE \_\_\_\_\_ 7 - 10 IN. LBS.

## 4. ENVIRONMENTAL

TEMPERATURE CYCLING \_\_\_\_\_ MIL-STD-202, METHOD 107, COND. C ( -65° c TO + 165° c )  
 SHOCK \_\_\_\_\_ MIL-STD-202, METHOD 213, COND. I (100 G's)  
 VIBRATION \_\_\_\_\_ MIL-STD-202, METHOD 204, COND. D (20 G's)  
 MOISTURE RESISTANCE \_\_\_\_\_ MIL-STD-202, METHOD 106, LESS STEP 7b  
 CORROSION \_\_\_\_\_ MIL-STD-202, METHOD 101, COND. B (48 HOURS)  
 BAROMETRIC PRESSURE (ALTITUDE) \_\_\_\_\_ MIL-STD-202, METHOD 105, COND. C ( 70,000 FT. ) ( 250 VRMS )

## 5. MATERIAL

BODY, BUSHING, COUPLING NUT, CLAMP NUT, \_\_\_\_\_ STAINLESS STEEL PER ASTM-A-582, TYPE 303, COND. A  
 PRESS SLEEVE & CUBE  
 CONTACT & RETAINING RING \_\_\_\_\_ BERYLLIUM COPPER PER ASTM-B-196/B, 196M-03, COPPER  
 ALLOY No. UNS-C17300, TEMPER TD04.  
 INSULATORS \_\_\_\_\_ TEFLON PER ASTM-D-1710-02, TYPE 1, GRADE 1, CLASS B.  
 GASKET & O-RING \_\_\_\_\_ SILICONE RUBBER PER ZZ-R-765.  
 SOLDER SLEEVE \_\_\_\_\_ BRASS PER ASTM-B-16, TEMPER H02, ALLOY C36000.

## 6. FINISH

BODY, BUSHING, COUPLING NUT, CLAMP NUT, \_\_\_\_\_ PASSIVATE PER AMS-2700, TYPE 2, CLASS 4.  
 PRESS SLEEVE & CUBE  
 SOLDER SLEEVE \_\_\_\_\_ GOLD PER ASTM-B-488, TYPE I, CODE C, CLASS 1.27  
 (.000050 MIN. THK.) OVER NICKEL PER SAE-AMS-QQ-N-290  
 CLASS 1 (.000150 MIN. THK.) OVER COPPER PER AMS-2418  
 (.000010 MIN. THK.)  
 CONTACT \_\_\_\_\_ GOLD PER ASTM-B-488, TYPE I, CODE C, CLASS 1.27  
 (.000050 MIN. THK.) OVER NICKEL PER SAE-AMS-QQ-N-290  
 CLASS 1 (.000050 MIN. THK.) OVER COPPER PER AMS-2418  
 (.000010 MIN. THK.)  
 INSULATORS, RETAINING RING, GASKET & O-RING \_\_\_\_\_ N/A