

SPECIFICATION CONTROL DRAWING

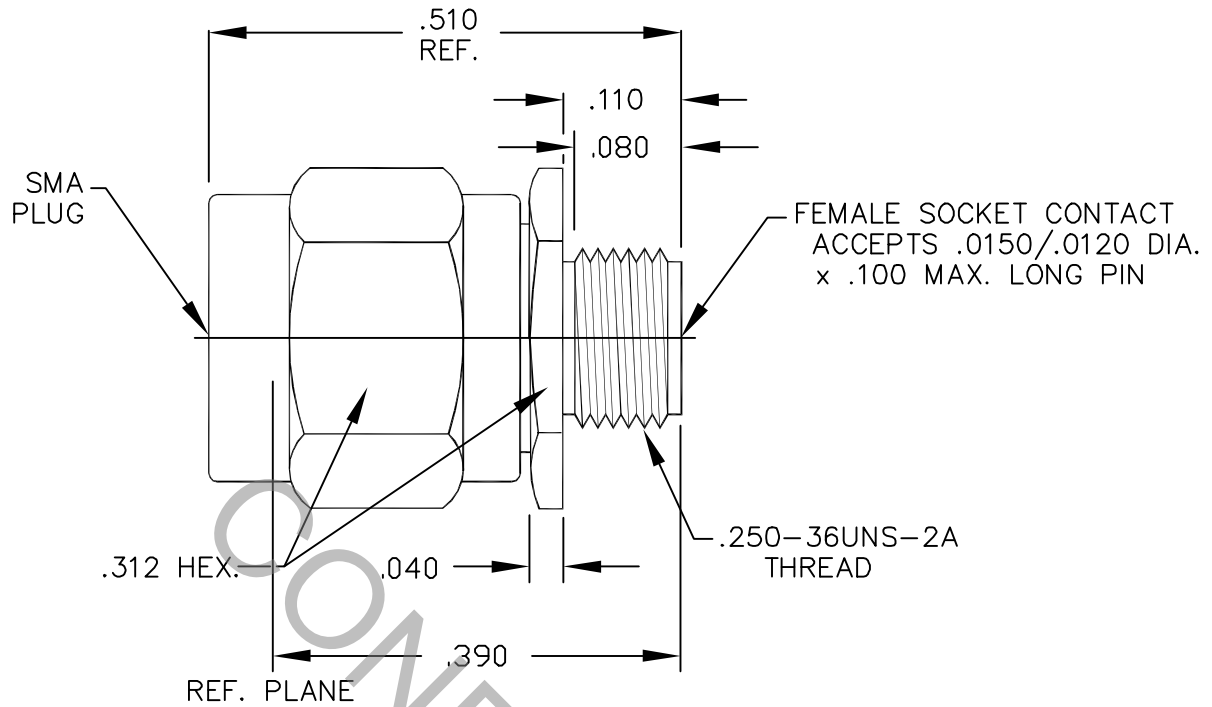

1. MATING INTERFACE DIMENSIONS FOR SMA PLUG per MIL-STD-348 (Fig. 310-1).

2. ELECTRICAL

FREQUENCY RANGE GHz	_____	DC TO 26.5 GHz
VSWR (MAX.) *	_____	1.05 + .006 x FGHz
INSERTION LOSS (dB MAX.) *	_____	.04 dB x $\sqrt{\text{FGHz}}$
NOMINAL IMPEDANCE (OHMS)	_____	50
VOLTAGE RATING (MAX. VRMS)	_____	250
RF LEAKAGE (MIN. dB DOWN)	_____	100 dB - FGHz
TEMPERATURE RATING (DEGREES CENTIGRADE)	_____	-65°C TO + 165 °C
DIELECTRIC WITHSTANDING VOLTAGE (MAX. VRMS)	_____	750
INSULATION RESISTANCE (MIN. MEGOHMS)	_____	10,000
CONTACT RESISTANCE		
• CENTER CONTACT (MAX. MILLIOHMS)	_____	3.0
• OUTER CONTACT (MAX. MILLIOHMS)	_____	2.0

*TERMINATED IN A 50 OHM LOAD

REV.	DCN NO.	DATE	APP.	DIMENSIONS ARE IN INCHES TOLERANCES			 HAVERHILL, MA. 01835
				DECIMALS .X ± .030 .XX ± .010 .XXX ± .005	FRACTIONAL ±/64	ANGULAR X ° ± 1 0' X ° X' ± 15'	
AA	03-1598	5/6/03	DC				
AB	06-1094	1/25/06	DC				
				SURFACE ROUGHNESS 63 $\sqrt{\text{MIL-STD-10}}$.			
				DRAWN DC	DATE 5/6/03	TITLE FIELD REPLACEABLE SMA, PLUG THREAD-IN MOUNT	
				APPROVED DC	DATE 5/6/03		
				CODE IDENT. 2J899	SHEET 1 OF 2	DWG. NO.	9830-0081-6201

SPECIFICATION CONTROL DRAWING

3. MECHANICAL

CAPTIVATION-CENTER CONTACT
MAX.AXIAL FORCE _____ 6.0 LBS.
MAX. RADIAL TORQUE _____ N/A
CENTER CONTACT AXIAL FORCES
● INSERTION (MAX. OUNCES) _____ INTERFACE N/A / FLANGE END 32.0 OZ.
● WITHDRAWAL (MIN. OUNCES) _____ INTERFACE N/A / FLANGE END 2.0 OZ.
CONNECTOR ENGAGEMENT/DISENGAGEMENT (MAX. IN. LBS.) _____ 2.0
CONNECTOR DURABILITY (MIN. CYCLES) _____ 500
RECOMMENDED MATING TORQUE _____ 7 - 10 IN. LBS.

4. ENVIRONMENTAL

TEMPERATURE CYCLING _____ MIL-STD-202, METHOD 102, COND. C (-65 °C TO + 200 °C)
SHOCK _____ MIL-STD-202, METHOD 213, COND. I (100 G's)
VIBRATION _____ MIL-STD-202, METHOD 204, COND. D (20 G's)
MOISTURE RESISTANCE _____ MIL-STD-202, METHOD 106, LESS STEP 7b
CORROSION _____ MIL-STD-202, METHOD 101, COND. B (48 HOURS)
BAROMETRIC PRESSURE (ALTITUDE) _____ MIL-STD-202, METHOD 105, COND. C (70,000 FT.) (190 VRMS)

5. MATERIAL

BODY AND COUPLING NUT _____ STAINLESS STEEL PER ASTM A 581, FREE MACHINING, TYPE 303, COND. A.
CONTACT AND RETAINING RING _____ BERYLLIUM COPPER PER ASTM B196-90, COPPER ALLOY No. UNS C17300, TEMPER TD04.
INSULATOR _____ TEFLON PER ASTM D 4894.
GASKET _____ SILICONE RUBBER PER ZZ-R-765, CLASS IIB, GRADE 50 OR 60.

6. FINISH

BODY AND COUPLING NUT _____ PASSIVATE PER QQ-P-35C, TYPE VI.
CONTACT _____ GOLD per ASTM B 488, TYPE II, GRADE C, CLASS 2 (.000100 Minimum Thickness) OVER NICKEL per QQ-N-290, CLASS 1 (.000100 Minimum Thickness) OVER COPPER per MIL-C-14550 (.000010 Minimum Thickness).
INSULATOR, GASKET AND RETAINING RING _____ N/A