

# SPECIFICATION CONTROL DRAWING

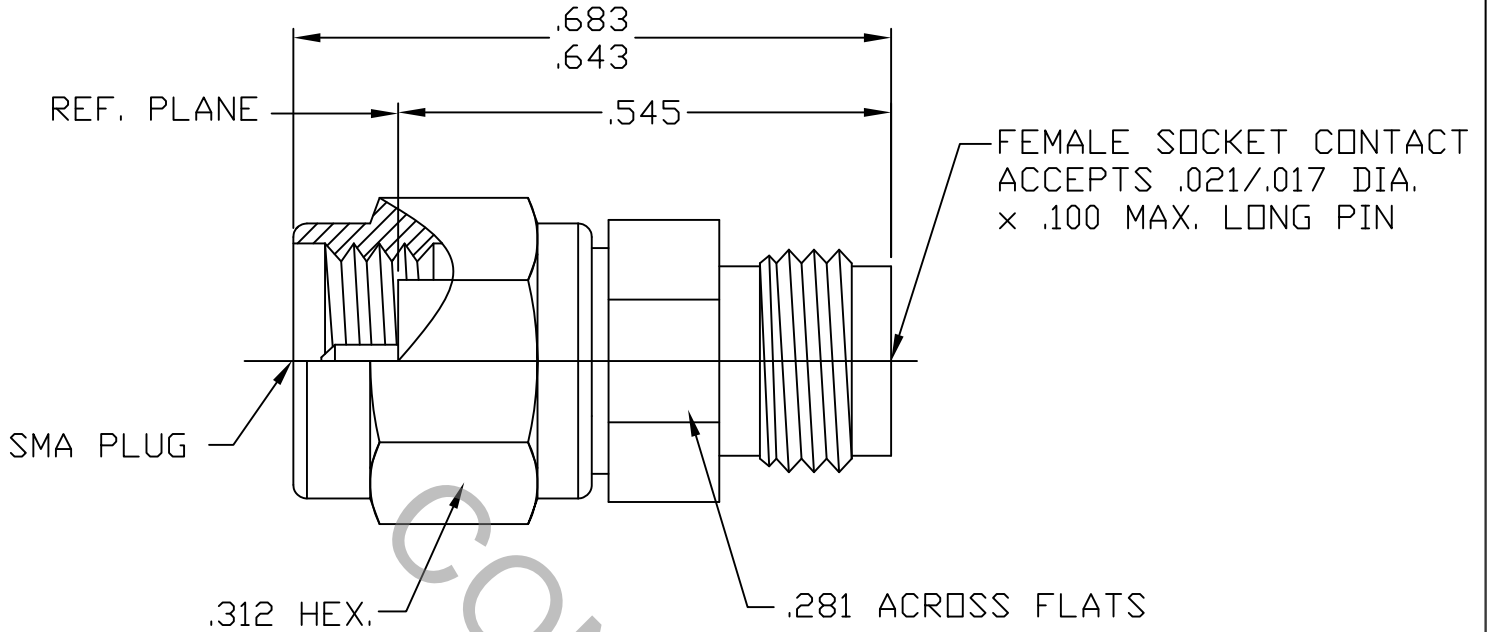

1. MATING INTERFACE DIMENSIONS Per MIL-STD-348 Fig. 310.1 (SMA, PLUG)

2. ELECTRICAL

FREQUENCY RANGE GHz	_____	DC TO 26.5 GHz
VSWR (MAX.) *	_____	1.05 + .006 x FGHz
INSERTION LOSS (dB MAX.) *	_____	.05 dB x FGHz
NOMINAL IMPEDANCE (OHMS)	_____	50
VOLTAGE RATING (MAX. VRMS)	_____	250
RF LEAKAGE (MIN. dB DOWN)	_____	-100 dB - FGHz
TEMPERATURE RATING (DEGREES CENTIGRADE)	_____	-65°C TO + 165 °C
DIELECTRIC WITHSTANDING VOLTAGE (MAX. VRMS)	_____	750
INSULATION RESISTANCE (MIN. MEGOHMS)	_____	5,000
CONTACT RESISTANCE		
• CENTER CONTACT (MAX. MILLIOHMS)	_____	6.0
• OUTER CONTACT (MAX. MILLIOHMS)	_____	2.0

\*TERMINATED IN A 50 OHM LOAD

**RoHS**  
COMPLIANT

This Document contains proprietary and confidential information.

REV.	DCN NO.	DATE	APP.	DIMENSIONS ARE IN INCHES TOLERANCES			 Haverhill, MA 01835
				DECIMALS	FRACTIONAL	ANGULAR	
-	397	6/87	TS	.X ± .030 .XX ± .010 .XXX ± .005	± 1/64	X ° ± 1° 0' X ° X' ± 15'	
A	518	2/88	DGG				
B	950	4/93	MB	DRAWN TS	DATE 6/87		TITLE SMA, PLUG SCREW-IN
BA	14-1166	2/6/14	DC	APPROVED DGG	DATE 6/87		FIELD REPLACEABLE ACCEPTS Ø.021/.017 PIN
				CODE IDENT. 2J899	SHEET 1 OF 2	DWG. NO. 9830-0081-6222	

# SPECIFICATION CONTROL DRAWING

## 3. MECHANICAL

CAPTIVATION-CENTER CONTACT  
MAX. AXIAL FORCE \_\_\_\_\_ 4.5 LBS.  
MAX. RADIAL TORQUE \_\_\_\_\_ N/A  
CENTER CONTACT AXIAL FORCES  
● INSERTION (MAX. OUNCES) \_\_\_\_\_ REAR 40.0  
● WITHDRAWAL (MIN. OUNCES) \_\_\_\_\_ REAR 1.0  
CONNECTOR ENGAGEMENT/DISENGAGEMENT (MAX. IN. LBS.) \_\_\_\_\_ 2.0  
CONNECTOR DURABILITY (MIN. CYCLES) \_\_\_\_\_ 500  
RECOMMENDED MATING TORQUE \_\_\_\_\_ 7 - 10 IN. LBS.  
RECOMMENDED MOUNTING TORQUE \_\_\_\_\_ 23 - 20 IN. LBS.

## 4. ENVIRONMENTAL

TEMPERATURE CYCLING \_\_\_\_\_ MIL-STD-202, METHOD 102, COND. C ( -65 °c TO +165 c° )  
SHOCK \_\_\_\_\_ MIL-STD-202, METHOD 213, COND. I (100 G's)  
VIBRATION \_\_\_\_\_ MIL-STD-202, METHOD 204, COND. D (20 G's)  
MOISTURE RESISTANCE \_\_\_\_\_ MIL-STD-202, METHOD 106, LESS STEP 7b  
CORROSION \_\_\_\_\_ MIL-STD-202, METHOD 101, COND. B (48 HOURS)  
BAROMETRIC PRESSURE (ALTITUDE) \_\_\_\_\_ MIL-STD-202, METHOD 105, COND. C ( 70,000 FT. ) ( 190 VRMS )

## 5. MATERIAL

BODY AND COUPLING NUT \_\_\_\_\_ STAINLESS STEEL PER ASTM-A-582, TYPE 303, COND. A  
CONTACT AND RETAINING RING \_\_\_\_\_ BERYLLIUM COPPER PER ASTM-B-196/B, 196M-03, COPPER ALLOY No. UNS-C17300, TEMPER TD04.  
INSULATOR \_\_\_\_\_ TEFLON PER ASTM-D-1710-02, TYPE 1, GRADE 1, CLASS B.  
GASKET \_\_\_\_\_ SILICONE RUBBER PER AMS-3304, GRADE 70

## 6. FINISH

BODY AND COUPLING NUT \_\_\_\_\_ PASSIVATE PER AMS-2700, TYPE 2, CLASS 4.  
CONTACT \_\_\_\_\_ GOLD PER ASTM-B-488, TYPE I, CODE C, CLASS 1.27 (.000050 MIN. THK.) OVER NICKEL PER SAE-AMS-QQ-N-290 CLASS 1 (.000050 MIN. THK.) OVER COPPER PER AMS-2418 (.000010 MIN. THK.)  
INSULATOR, GASKET AND RETAINING RING \_\_\_\_\_ N/A