

SPECIFICATION CONTROL DRAWING

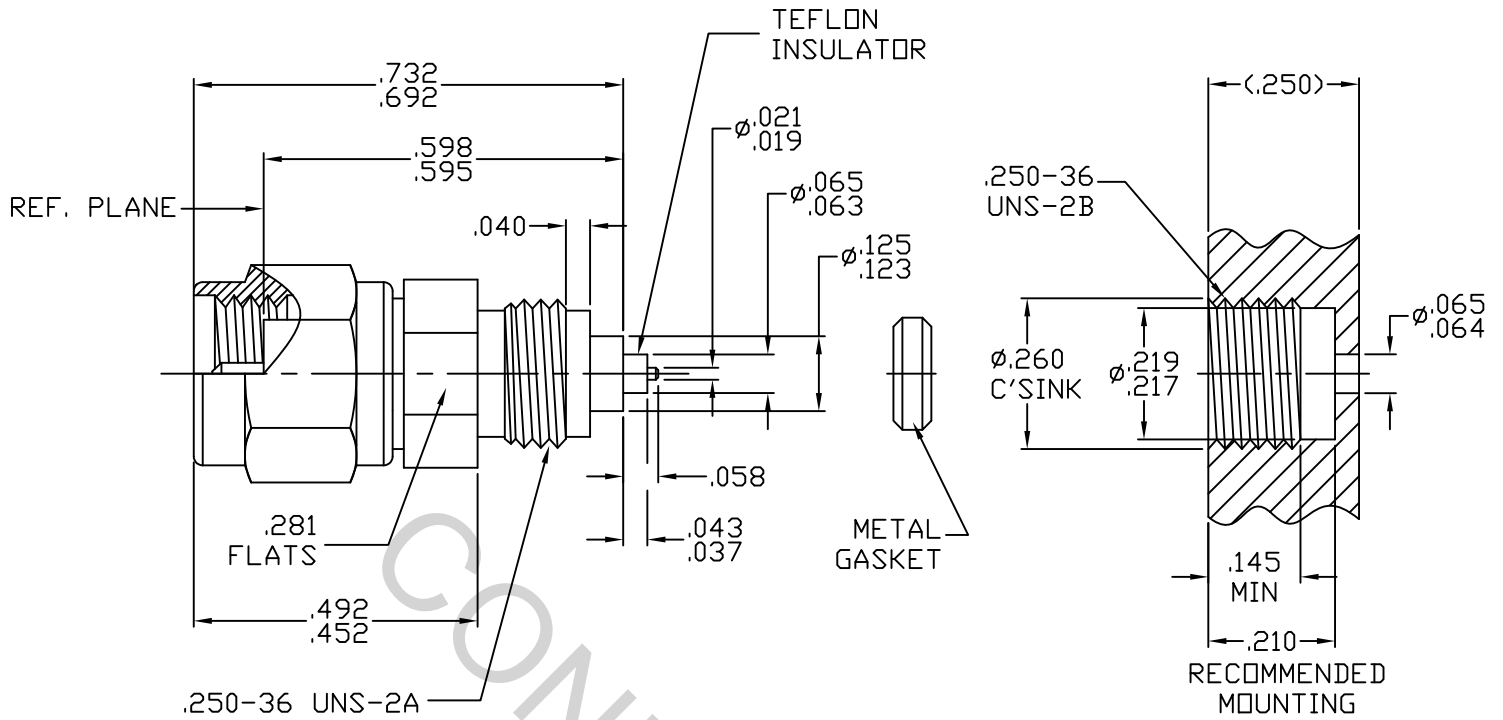

1. MATING INTERFACE DIMENSIONS Per MIL-STD-348 Fig. 310.1 (SMA, PLUG)

2. ELECTRICAL

FREQUENCY RANGE GHz	_____	DC TO 26.5 GHz
VSWR (MAX) *	_____	1.05 + .010 x FGHz
INSERTION LOSS (dB MAX) *	_____	.04 dB x √FGHz
NOMINAL IMPEDANCE (OHMS)	_____	50
VOLTAGE RATING (MAX. VRMS)	_____	250
RF LEAKAGE (MIN. dB DOWN)	_____	-100 dB - FGHz
TEMPERATURE RATING (DEGREES CENTIGRADE)	_____	-65°C TO + 165°C
DIELECTRIC WITHSTANDING VOLTAGE (MAX. VRMS)	_____	750
INSULATION RESISTANCE (MIN. MEGOHMS)	_____	10,000
CONTACT RESISTANCE		
• CENTER CONTACT (MAX. MILLIOHMS)	_____	12.0
• OUTER CONTACT (MAX. MILLIOHMS)	_____	2.0

* TERMINATED IN A 50 OHM LOAD

This Document contains proprietary and confidential information.

RoHS
COMPLIANT

REV.	DCN NO.	DATE	APP.	DIMENSIONS ARE IN INCHES TOLERANCES			 HAVERHILL, MA 01835
AA	18-1735	7/13/18	DC	DECIMALS	FRACTIONAL	ANGULAR	
				± .030 XX ± .010 XXX ± .005	± 1/64	X ° ± 0' X ° X' ± 15'	
				DRAWN MS	DATE 7/13/18		TITLE SMA, PLUG SPARK PLUG HERMETICALLY SEALED WITH METAL GASKET
				APPROVED DC	DATE 7/13/18		
				CODE IDENT. 2J899	SHEET 1 OF 2	DWG. NO. 9830-0431-6422	

SPECIFICATION CONTROL DRAWING

3. MECHANICAL

CAPTIVATION-CENTER CONTACT
 MAX AXIAL FORCE _____ 4.5 LBS.
 MAX RADIAL TORQUE _____ N/A
 CENTER CONTACT AXIAL FORCES
 ● INSERTION (MAX. OUNCES) _____ N/A
 ● WITHDRAWAL (MIN. OUNCES) _____ N/A
 CONNECTOR ENGAGEMENT/DISENGAGEMENT (MAX. IN. LBS.) — 2.0
 CONNECTOR DURABILITY (MIN. CYCLES) _____ 500
 RECOMMENDED MATING TORQUE _____ 7 - 10 IN. LBS.
 RECOMMENDED MOUNTING TORQUE _____ 23 - 20 IN. LBS.

4. ENVIRONMENTAL

TEMPERATURE CYCLING _____ MIL-STD-202, METHOD 102, COND. C (-65° c TO +200° c)
 SHOCK _____ MIL-STD-202, METHOD 213, COND. I (100 G's)
 VIBRATION _____ MIL-STD-202, METHOD 204, COND. D (20 G's)
 MOISTURE RESISTANCE _____ MIL-STD-202, METHOD 106, LESS STEP 7b
 CORROSION _____ MIL-STD-202, METHOD 101, COND. B (48 HOURS)
 BAROMETRIC PRESSURE (ALTITUDE) _____ MIL-STD-202, METHOD 105, COND. C (70,000 FT.) (190 VRMS)
 HERMETICITY _____ 1 x 10⁻⁸ cc/SEC.

5. MATERIAL

BODY AND COUPLING NUT _____ STAINLESS STEEL PER ASTM-A-582, TYPE 303, COND. A
 CONTACT AND RETAINING RING _____ BERYLLIUM COPPER PER ASTM B196/B, 196M-03, COPPER ALLOY No. UNS-C17300, TEMPER TD04.
 INSULATOR _____ TEFLON PER ASTM D 1710-02, TYPE 1, GRADE 1, CLASS B.
 GASKET _____ SILICONE RUBBER PER ZZ-R-765, CLASS IIB, GRADE 50 OR 60.
 GLASS PIN _____ KOVAR PER MIL-I-23011
 GLASS _____ CORNING 7070
 RUBBER GASKET _____ SILICONE RUBBER PER ZZ-R-765, CLASS IIB, GRADE 50 OR 60.

6. FINISH

BODY AND GLASS PIN _____ GOLD PER ASTM-B-488, TYPE II, CODE C, CLASS 1.27 (.000050 MIN. THK.) OVER NICKEL PER QQ-N-290, CLASS 1 (.000150 MIN. THK.) OVER COPPER PER AMS 2418 (.000010 MIN. THK.)
 COUPLING NUT _____ PASSIVATE PER AMS-2700, TYPE 2, CLASS 4.
 CONTACT _____ GOLD PER ASTM-B-488, TYPE II, CODE C, CLASS 1.27 (.000050 MIN. THK.) OVER NICKEL PER QQ-N-290, CLASS 1 (.000050 MIN. THK.) OVER COPPER PER AMS 2418 (.000010 MIN. THK.)
 METAL GASKET _____ NICKEL PER MIL-C-26074, CLASS 1, (.00010 MIN. THK.) OVER COPPER PER AMS-2418, CLASS 4 (.00010 MIN. THK.) OVER NICKEL (WOODS OR WATTS), (.000010 MIN. THK.)
 GLASS, INSULATOR, _____ N/A
 GASKET AND RETAINING RING