

# SPECIFICATION CONTROL DRAWING

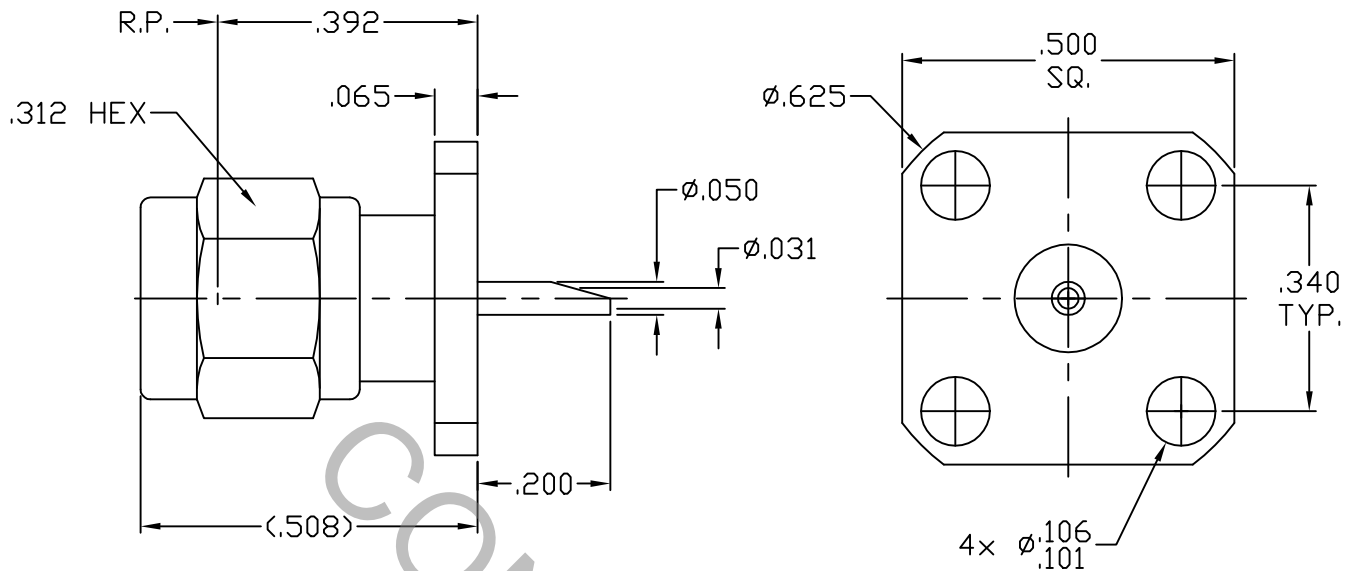

1. MATING INTERFACE DIMENSIONS FOR SMA PLUG per MIL-STD-348 (Fig. 310-1).

## 2. ELECTRICAL

FREQUENCY RANGE GHz	_____	DC TO 18.0 GHz
VSWR (MAX.) *	_____	1.05 + .008 x FGHz
INSERTION LOSS (dB MAX.) *	_____	.04 dB x √FGHz
NOMINAL IMPEDANCE (OHMS)	_____	50
VOLTAGE RATING (MAX. VRMS)	_____	335
RF LEAKAGE (MIN. dB DOWN)	_____	100 dB - FGHz
TEMPERATURE RATING (DEGREES CENTIGRADE)	_____	-65°C TO + 150°C
DIELECTRIC WITHSTANDING VOLTAGE (MAX. VRMS)	_____	1,000
INSULATION RESISTANCE (MIN. MEGOHMS)	_____	10,000
CONTACT RESISTANCE		
• CENTER CONTACT (MAX. MILLIOHMS)	_____	3.0
• OUTER CONTACT (MAX. MILLIOHMS)	_____	2.0

\*TERMINATED IN A 50 OHM LOAD

REV.	DCN NO.	DATE	APP.	DIMENSIONS ARE IN INCHES TOLERANCES			 HAVERHILL, MA. 01835
AA	05-1462	4/12/05	DC	DECIMALS .X ± .030 .XX ± .010 .XXX ± .005	FRACTIONAL ±/64	ANGULAR X° ± 1 0' X° X' ± 15'	
				SURFACE ROUGHNESS 63 √MIL-STD-10.			TITLE SMA PLUG EPOXY CAPTURED SOLDER POT
				DRAWN	DC	DATE 4/12/05	
				APPROVED	DC	DATE 4/12/05	
				CODE IDENT. 2J899	SHEET 1 OF 2		DWG. NO. 9854-0022-6200

# SPECIFICATION CONTROL DRAWING

## 3. MECHANICAL

CAPTIVATION—CENTER CONTACT  
MAX.AXIAL FORCE \_\_\_\_\_ 6.0 LBS.  
MAX. RADIAL TORQUE \_\_\_\_\_ 4.0 IN. OZ.  
CENTER CONTACT AXIAL FORCES  
● INSERTION (MAX. OUNCES) \_\_\_\_\_ N/A  
● WITHDRAWAL (MIN. OUNCES) \_\_\_\_\_ N/A  
CONNECTOR ENGAGEMENT/DISENGAGEMENT (MAX. IN. LBS.) — 2.0  
CONNECTOR DURABILITY (MIN. CYCLES) \_\_\_\_\_ 500  
RECOMMENDED MATING TORQUE \_\_\_\_\_ 7 - 10 IN. LBS.

## 4. ENVIRONMENTAL

TEMPERATURE CYCLING \_\_\_\_\_ MIL-STD-202, METHOD 102, COND. C ( -65 °c TO + 165 ℘ )  
SHOCK \_\_\_\_\_ MIL-STD-202, METHOD 213, COND. I (100 G's)  
VIBRATION \_\_\_\_\_ MIL-STD-202, METHOD 204, COND. D (20 G's)  
MOISTURE RESISTANCE \_\_\_\_\_ MIL-STD-202, METHOD 106, LESS STEP 7b  
CORROSION \_\_\_\_\_ MIL-STD-202, METHOD 101, COND. B (48 HOURS)  
BAROMETRIC PRESSURE (ALTITUDE) \_\_\_\_\_ MIL-STD-202, METHOD 105, COND. C ( 70,000 FT. ) ( 250 VRMS )

## 5. MATERIAL

BODY AND COUPLING NUT \_\_\_\_\_ STAINLESS STEEL PER ASTM A 582, TYPE 303, COND A.  
CONTACT AND RETAINING RING \_\_\_\_\_ BERYLLIUM COPPER PER QQ-C-530, ALLOY 173 COND. HT  
No. UNS C17300, TEMPER TD04.  
INSULATOR \_\_\_\_\_ TEFLON PER D 1457  
GASKET \_\_\_\_\_ SILICONE RUBBER per ZZ-R-765  
CLASS IIB, GRADE 50 or 60.

## 6. FINISH

BODY AND COUPLING NUT \_\_\_\_\_ PASSIVATE PER QQ-P-35A, TYPE I  
CONTACT \_\_\_\_\_ GOLD per ASTM-B-488, TYPE I, CODE C, CLASS 2.5  
(.000100 Minimum Thickness) OVER NICKEL per  
QQ-N-290, (.000050 Minimum Thickness) OVER  
COPPER per MIL-C-14550 (.000010 Minimum Thickness).  
INSULATOR, GASKET AND RETAINING RING \_\_\_\_\_ N/A