

SPECIFICATION CONTROL DRAWING

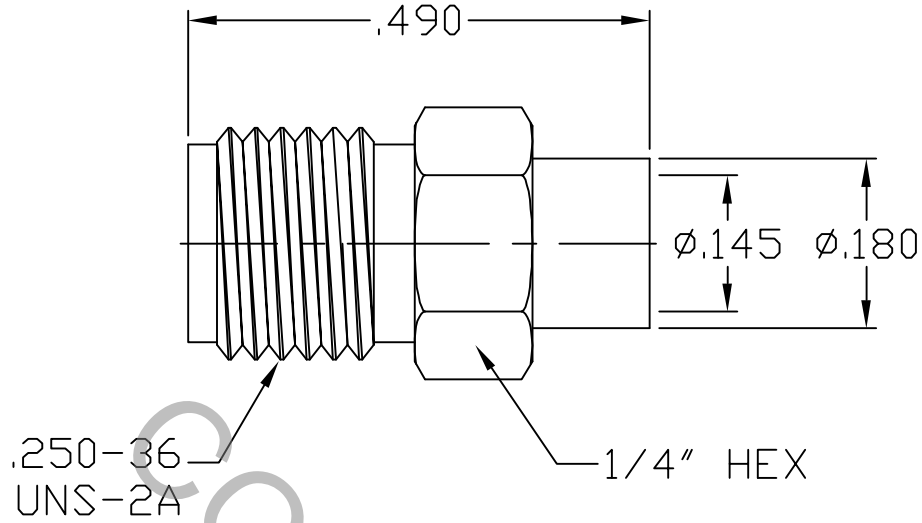

1. MATING INTERFACE DIMENSIONS FOR SMA JACK per MIL-STD-348 (Fig. 310-2).

2. ELECTRICAL

FREQUENCY RANGE GHz	_____	DC TO 2.0 GHz
VSWR (MAX.) *	_____	1.65:1
INSERTION LOSS (dB MAX.) *	_____	.12 dB x $\sqrt{\text{FGHz}}$
NOMINAL IMPEDANCE (OHMS)	_____	50
VOLTAGE RATING (MAX. VRMS)	_____	170
RF LEAKAGE (MIN. dB DOWN)	_____	100 dB - FGHz
TEMPERATURE RATING (DEGREES CENTIGRADE)	_____	-65 °c TO + 165 °c
DIELECTRIC WITHSTANDING VOLTAGE (MAX. VRMS)	_____	500
INSULATION RESISTANCE (MIN. MEGOHMS)	_____	5,000
CONTACT RESISTANCE		
• CENTER CONTACT (MAX. MILLIOHMS)	_____	6.0
• OUTER CONTACT (MAX. MILLIOHMS)	_____	2.0

*TERMINATED TO A 25 OHM CABLE

REV.	DCN NO.	DATE	APP.	DIMENSIONS ARE IN INCHES TOLERANCES			 HAVERHILL MA. 01835
				DECIMALS	FRACTIONAL	ANGULAR	
AA	05-2153	11/4/05	DC	.X ± .030 .XX ± .010 .XXX ± .005	± 1/64	X ° ± 1'0" X ° X' ± 15'	TITLE SMA JACK DIRECT SOLDER .141 DIA. 25 OHM SEMI-RIGID CABLE
AB	05-2310	12/9/05	DC				
				DRAWN SS	DATE 11/4/05		DWG. NO. 9900-0020-6401
				APPROVED DC	DATE 11/4/05		
				CODE IDENT. 2J899	SHEET 1 OF 2		

SPECIFICATION CONTROL DRAWING

3. MECHANICAL

CAPTIVATION-CENTER CONTACT

MAX. AXIAL FORCE _____ N/A

MAX. RADIAL TORQUE _____ N/A

CENTER CONTACT AXIAL FORCES

● INSERTION (MAX. OUNCES) _____ INTERFACE 32.0

● WITHDRAWAL (MIN. OUNCES) _____ INTERFACE 2.0

CONNECTOR ENGAGEMENT/DISENGAGEMENT(MAX. IN. LBS.) _____ 2.0

CONNECTOR DURABILITY (MIN. CYCLES) _____ 500

RECOMMENDED MATING TORQUE _____ 7 - 10 IN. LBS.

4. ENVIRONMENTAL

TEMPERATURE CYCLING _____ MIL-STD-202, METHOD 102, COND. C (-55° c TO + 165° c)

SHOCK _____ MIL-STD-202, METHOD 213, COND. I (100 G's)

VIBRATION _____ MIL-STD-202, METHOD 204, COND. D (20 G's)

MOISTURE RESISTANCE _____ MIL-STD-202, METHOD 106, LESS STEP 7b

CORROSION _____ MIL-STD-202, METHOD 101, COND. B (48 HOURS)

BAROMETRIC PRESSURE (ALTITUDE) _____ MIL-STD-202, METHOD 105, COND. C (70,000 FT.) (125 VRMS)

5. MATERIAL

CONNECTOR BODY _____ STAINLESS STEEL PER AMS-5640, TYPE 303, COND. A

CONTACT _____ BERYLLIUM COPPER PER QQ-C-530, ALLOY 173, COND. H.T.

INSULATOR _____ TEFLON

6. FINISH

BODY _____ GOLD per ASTM-B-488, TYPE I, CODE C, CLASS 1.25
(.000050 MIN. THK.) OVER NICKEL per QQ-N-290, CLASS 1
(.000150 MIN. THK.) OVER NICKEL (WOODS OR WATTS)
(.000010 MIN. THK.).

CONTACT _____ GOLD per ASTM-B-488, TYPE I, CODE C, CLASS 2.5
(.000100 MIN. THK.) OVER NICKEL per QQ-N-290
(.000050 MIN. THK.) OVER COPPER PER MIL-C-14550
(.000010 MIN. THK.).

INSULATOR _____ N/A