

# SPECIFICATION CONTROL DRAWING

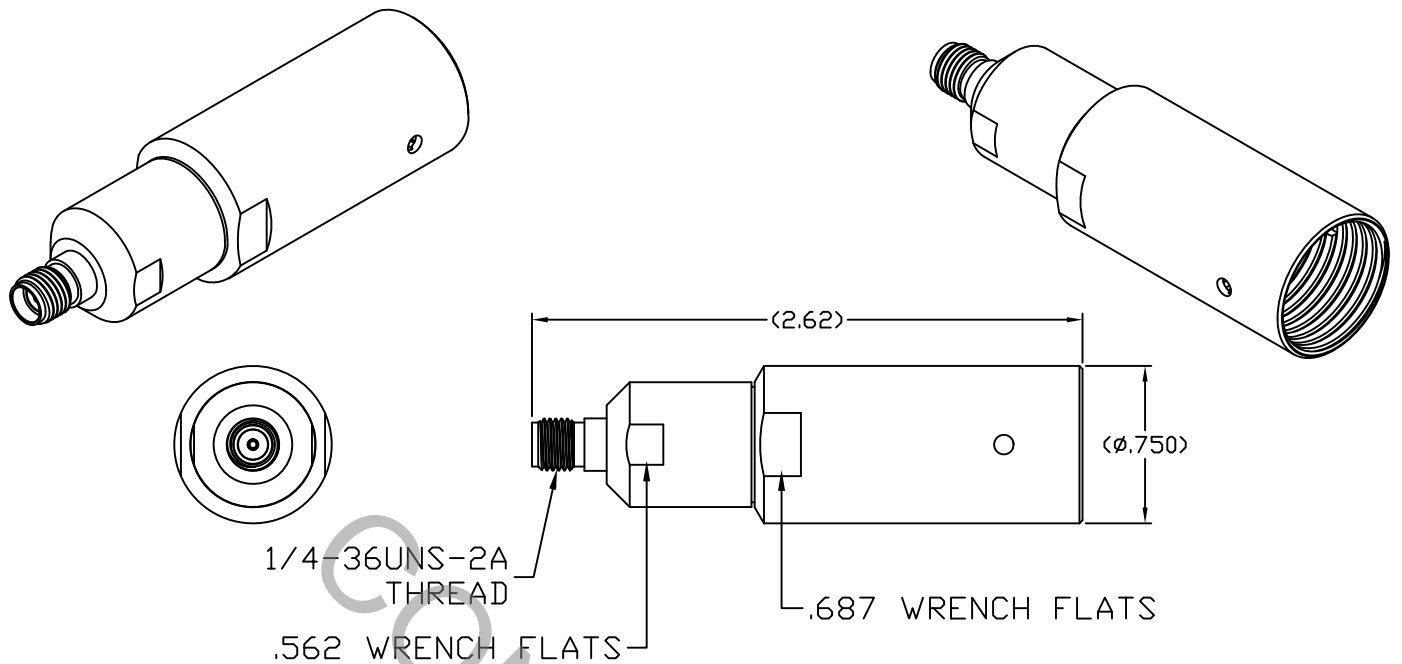

SOLD ON DYNAWAVE CABLE ASSEMBLIES ONLY

1. MATING INTERFACE DIMENSIONS Per MIL-STD-348 Fig. 310.2 (SMA JACK).

## 2. ELECTRICAL

FREQUENCY RANGE GHz	_____	DC TO 18.0 GHz
VSWR (MAX) *	_____	1.05 + .005 x FGHz
INSERTION LOSS (dB MAX) *	_____	.04 dB x $\sqrt{\text{FGHz}}$
NOMINAL IMPEDANCE (OHMS)	_____	50
VOLTAGE RATING (MAX. VRMS)	_____	333
RF LEAKAGE (MIN. dB DOWN)	_____	-100 dB - FGHz
TEMPERATURE RATING (DEGREES CENTIGRADE)	_____	-65°C TO + 165°C
DIELECTRIC WITHSTANDING VOLTAGE (MAX. VRMS)	_____	1,000
INSULATION RESISTANCE (MIN. MEGOHMS)	_____	5,000
CONTACT RESISTANCE		
• CENTER CONTACT (MAX. MILLIOHMS)	_____	6.0
• OUTER CONTACT (MAX. MILLIOHMS)	_____	2.0

\* TERMINATED IN A 50 OHM LOAD

**RoHS**  
COMPLIANT

REV.	DCN NO.	DATE	APP.	DIMENSIONS ARE IN INCHES TOLERANCES			 Haverhill, MA 01835
AA	12-2149	11/20/12	DC	DECIMALS .X ± .030 .XX ± .010 .XXX ± .005	FRACTIONAL ± 1/64	ANGULAR X ° ± 1° 0' X ° X' ± 15'	
				DRAWN RMS	DATE	11/19/12	TITLE SMA JACK, SOLDER CLAMP, ARMORED DF218 LOW LOSS
				APPROVED DC	DATE	11/20/12	
				CODE IDENT. 6DZL5	SHEET 1 OF 2		DWG. NO. 9900-218A-6240

# SPECIFICATION CONTROL DRAWING

## 3. MECHANICAL

### CAPTIVATION-CENTER CONTACT

MAX AXIAL FORCE \_\_\_\_\_ 6.0 LBS.

MAX RADIAL TORQUE \_\_\_\_\_ N/A

### CENTER CONTACT AXIAL FORCES

● INSERTION (MAX. OUNCES) \_\_\_\_\_ INTERFACE 32.0

● WITHDRAWAL (MIN. OUNCES) \_\_\_\_\_ INTERFACE 2.0

CONNECTOR ENGAGEMENT/DISENGAGEMENT (MAX. LBS.) \_\_\_\_\_ 2.0

CONNECTOR DURABILITY (MIN. CYCLES) \_\_\_\_\_ 500

RECOMMENDED MATING TORQUE \_\_\_\_\_ N/A

## 4. ENVIRONMENTAL

THERMAL SHOCK \_\_\_\_\_ MIL-STD-202, METHOD 107, COND. B ( -65° c TO + 165° c )

SHOCK \_\_\_\_\_ MIL-STD-202, METHOD 213, COND. I (100 G's)

VIBRATION \_\_\_\_\_ MIL-STD-202, METHOD 204, COND. D (20 G's)

MOISTURE RESISTANCE \_\_\_\_\_ MIL-STD-202, METHOD 106, LESS STEP 7b

CORROSION \_\_\_\_\_ MIL-STD-202, METHOD 101, COND. B (48 HOURS)

BAROMETRIC PRESSURE (ALTITUDE) \_\_\_\_\_ MIL-STD-202, METHOD 105, COND. C ( 70,000 FT. ) ( 250 VRMS )

## 5. MATERIAL

BODY, CLAMP NUT & PRESS SLEEVE \_\_\_\_\_ STAINLESS STEEL PER ASTM-A-582, TYPE 303, COND. A

CONTACT \_\_\_\_\_ BERYLLIUM COPPER PER ASTM-B-196-90, COPPER ALLOY  
No. UNS-C17300, TEMPER TD04.

FRONT INSULATOR \_\_\_\_\_ TEFLON PER ASTM-D-1710-02, TYPE 1, GRADE 1, CLASS B.

REAR INSULATOR \_\_\_\_\_ CROSS LINKED POLYETHYLENE (200°C).

O-RING \_\_\_\_\_ SILICONE RUBBER PER ZZ-R-765.

SOLDER SLEEVE \_\_\_\_\_ BRASS PER ASTM-B-16, TEMPER H02, ALLOY C36000.

## 6. FINISH

BODY, CLAMP NUT & PRESS SLEEVE \_\_\_\_\_ PASSIVATE PER AMS-2700, TYPE 2, CLASS 4.

SOLDER SLEEVE \_\_\_\_\_ GOLD PER ASTM-B-488, TYPE I, CODE C, CLASS 1.27  
(.000050 MIN. THK.) OVER NICKEL PER SAE-AMS-QQ-N-290  
CLASS 1 (.000150 MIN. THK.) OVER NICKEL (WOODS OR WATTS)  
(.000010 MIN. THK.)

CONTACTS \_\_\_\_\_ GOLD PER ASTM-B-488, TYPE I, CODE C, CLASS 0.75  
(.000030 MIN. THK.) OVER NICKEL PER SAE-AMS-QQ-N-290  
CLASS 1 (.000050 MIN. THK.) OVER COPPER PER AMS-2418  
(.000010 MIN. THK.)

INSULATORS & O-RING \_\_\_\_\_ N/A